



EN

Instructions for use (Technical and Operational Documentation)

Floor mounted air handling units with reversible heat pump.

VENTUS COMPACT HP VVS021c-VVS075c

CE

VENTUS

IOMM VENTUS - ver. 6.0.1 (06.2026)

Content

1	HEALTH AND SAFETY INSTRUCTIONS	5
2	GENERAL INFORMATION	12
3	HEAT PUMP SYSTEM	16
3.1	HEAT PUMP CONTROL.....	19
3.1.1	EXCHANGER DEFROSTING	20
3.1.2	FAILURE PROTECTION SYSTEM.....	21
4	PREPARATION FOR INSTALLATION	22
4.1	TRANSPORT AND STORAGE.....	22
4.2	PREPARATION FOR INSTALLATION.....	24
4.2.1	LOCATION OF THE DEVICE.....	24
4.2.2	INSTALLATION OF <i>VENTUS COMPACT HP</i>	25
4.2.3	CONNECTING AIR DUCTS.....	31
4.2.4	CONNECTING BASE BLOCK SECTIONS	32
5	CONNECTION OF WATER HEATER	34
5.1	CONNECTION OF WATER HEATERS	34
5.2	CONDENSATE DRAINAGE	37
6	ELECTRICAL CONNECTION	38
6.1	ELECTRICAL CONNECTION TO THE POWER BOX	38
7	ELECTRIC HEATER	41
7.1	GENERAL INFORMATION.....	41
7.2	HEATER POWER CONNECTION AND CURRENT PROTECTION	43
7.3	THERMAL CUT-OFF (THERMIC).....	47
7.4	DIFFERENTIAL PRESSURE SWITCH.....	48
7.5	CONNECTION OF ELECTRIC HEATER CONTROL	49
8	PLUG&PLAY CONTROLS COMPONENTS	52
8.1	STANDARD EQUIPMENT WITH FACTORY-FITTED CONTROLS ELEMENTS	53
8.2	CONNECTION TERMINAL 1 (T1).....	54
8.3	CABLE STANDARDS	55
8.4	ANALOGUE INPUTS (NTC10K)	56
8.4.1	SUPPLY AIR TEMPERATURE SENSOR B1	57
8.4.2	TOUCHSCREEN WATER HEATER TEMPERATURE SENSOR B5.....	58
8.5	DIGITAL INPUTS	59



8.5.1	FIRE ALARM SIGNAL DI1	60
8.5.2	WATER HEATER FREEZE SENSOR DI2.....	60
8.5.3	COLD SOURCE ALARM DI3.....	61
8.6	ANALOGUE OUTPUTS (0-10V DC).....	62
8.6.1	VALVE ACTUATOR OF THE WATER MAIN HEATER AND CONTROL SIGNAL OF THE ELECTRIC MAIN HEATER Y1	63
8.6.2	VALVE ACTUATOR FOR WATER PRE- OR POST-HEATER AFTER DX-H Y1.....	63
8.7	DIGITAL OUTPUTS (24V DC)	64
8.8	CONNECTION OF CONDENSING UNIT SIGNALS.....	65
8.9	CONNECTION OF THREE-WAY VALVES.....	66
8.10	GSM COMMUNICATION	67
8.11	MODBUS RTU RS485 COMMUNICATION	67
8.12	CONNECTION OF OPERATOR PANELS	69
8.12.1	HMI ADVANCED.....	69
8.12.2	HMI BASIC (2HY).....	70
8.12.3	WebHMI and VMS.....	71
8.12.4	mHMI APPLICATION - BLUETOOTH DEVICE PAIRING	72
9	FIRST START-UP	73
9.1	PREPARATION FOR THE FIRST START UP.....	73
9.1.1	CHECKING THE CONDITION OF THE INSTALLATION	73
9.1.2	POWER CONFIGURATION OF OPTIONAL ELECTRIC HEATERS	75
9.2	FIRST START-UP	76
9.2.1	FACTORY PARAMETERS	76
9.2.2	START UP	78
9.2.3	HMI ADVANCED.....	79
9.2.4	HMI BASIC 2HY	81
9.2.5	BLUETOOTH MODULE AND mHMI APPLICATION.....	86
9.2.6	OPERATING MODES OF THE CONTROL PANEL.....	96
9.2.7	VERIFICATION OF OPERATION DURING INITIAL START-UP	97
9.2.8	MEASUREMENT OF AIR VOLUME.....	99
9.2.9	THE MOST COMMON ADAPTATIONS OF PARAMETERS TO THE NEEDS OF THE FACILITY 100	
10	READING AND CONFIGURATION OF PARAMETERS.....	104
10.1	uPC3 Screens Description.....	104
10.2	READING OF HEAT PUMP PARAMETERS.....	104
11	MAINTENANCE	107

11.1	MAINTENANCE	107
11.2	CONSUMABLES.....	113
11.3	CONNECTION DIAGRAM OF THE DEVICE	115
11.3.1	VENTUS COMPACT HP AHU (1/11).....	115
11.3.2	VENTUS COMPACT HP AHU (2/11).....	116
11.3.3	VENTUS COMPACT HP AHU (3/11).....	117
11.3.4	VENTUS COMPACT HP AHU (4/11).....	118
11.3.5	VENTUS COMPACT HP AHU (5/11).....	119
11.3.6	VENTUS COMPACT HP AHU (6/11).....	120
11.3.7	CENTRAL VENTUS COMPACT HP (7/11)	121
11.3.8	VENTUS COMPACT HP AHU (8/11).....	122
11.3.9	AHU VENTUS COMPACT HP (9/11).....	123
11.3.10	VENTUS COMPACT HP AHU (10/11).....	124
11.3.11	CENTRAL VENTUS COMPACT HP (11/11)	125
12	ADDITIONAL INFORMATION.....	127
12.1	TECHNICAL INFORMATION FOR REGULATION (EU) N327/2011 IMPLEMENTING DIRECTIVE 2009/125/EC.....	127
12.2	ASSOCIATED INSTRUCTIONS	128
12.3	DISMANTLING AND DISPOSAL.....	128
12.4	NOTES.....	130
12.5	EU DECLARATION OF CONFORMITY.....	132

1 HEALTH AND SAFETY INSTRUCTIONS

Thorough familiarisation with the contents of this manual, as well as installation, commissioning and operation of the air handling unit in accordance with the instructions provided and in compliance with all applicable occupational health and safety regulations, will provide a sound basis for efficient, safe and trouble-free operation of the unit.

This document does not cover all possible configurations of these units, does not provide all examples of their assembly and installation, nor does it discuss all aspects of their commissioning, operation, repair and maintenance. If the units are used in accordance with their intended design purpose, both this documentation and any other materials dedicated to the supplied unit contain information intended exclusively for qualified technical personnel.

	This symbol is displayed to indicate issues and operations that may involve a risk. Carefully read the section marked with this symbol and follow the instructions
	WARNING
	DANGER
	Indicates that failure to follow the instructions may result in minor injury or damage to the product.
	Indicates that failure to follow the instructions may result in serious injury or death.

RECOMMENDATIONS REGARDING THE MANUAL

- Failure to follow the recommendations contained in this manual may result in property damage and personal injury. The manufacturer shall not be held liable for any damage that may result, directly or indirectly, from failure to observe these instructions.
- Depending on the configuration used, the unit may be supplied with additional manuals for the delivered components. It is strongly recommended to read and observe the safety requirements contained in those manuals.
- This manual and the air handling unit documentation, as well as any additional manuals for the components used, if available, must be carefully stored in a place that is easily accessible to operating and service personnel.



WARNING

INSTALLATION, SERVICE WORK AND USE

- ! BEFORE CARRYING OUT ANY WORK, DISCONNECT THE POWER SUPPLY AND SECURE IT AGAINST UNCONTROLLED START-UP OF THE AIR HANDLING UNIT. THE SERVICE WORK IN PROGRESS MUST BE COMMUNICATED AND CLEARLY MARKED.
- ! **THE UNIT IS FACTORY-CONFIGURED TO START AUTOMATICALLY WHEN THE POWER SUPPLY IS CONNECTED FOR THE FIRST TIME.**
- ! PERSONAL PROTECTIVE EQUIPMENT (PPE) MUST BE USED DURING WORK.
- ! IN PARTICULAR:
 - o CUT-RESISTANT GLOVES (EN 388) TO PROTECT HANDS AGAINST SHARP EDGES,
 - o SAFETY HELMET (EN 397) WHEN INSTALLING ABOVE HEAD HEIGHT, PROTECTIVE MASK TO PREVENT DUST AND DIRT PARTICLES FROM ENTERING THE LUNGS,
 - o SAFETY GOGGLES AND ANY OTHER PPE REQUIRED BY APPLICABLE REGULATIONS.
- ! ALL SERVICE ACTIVITIES MUST BE CARRIED OUT WITH THE UTMOST CARE.
- ! INSTALLATION, COMMISSIONING AND SERVICING OF AIR HANDLING UNITS AND THEIR EQUIPMENT MAY INVOLVE CERTAIN SAFETY HAZARDS AND THEREFORE REQUIRE SPECIFIC KNOWLEDGE AND TRAINING.
- ! INSTALLATION, COMMISSIONING AND OPERATION OF THE UNIT MUST BE CARRIED OUT BY A PERSON HOLDING THE APPROPRIATE QUALIFICATIONS REQUIRED BY APPLICABLE REGULATIONS.
- ! IT IS RECOMMENDED THAT INSTALLATION, COMMISSIONING, POST-WARRANTY REPAIRS, TECHNICAL INSPECTIONS AND MAINTENANCE WORK REQUIRED FOR AIR HANDLING UNITS BE CARRIED OUT BY A VTS-AUTHORIZED SERVICE PROVIDER.
- ! UNITS THAT ARE INCORRECTLY INSTALLED, ADJUSTED OR REPAIRED BY A PERSON WITHOUT THE REQUIRED QUALIFICATIONS MAY CAUSE SERIOUS PERSONAL INJURY OR EVEN DEATH. THE ABOVE RELEASES THE MANUFACTURER FROM LIABILITY AND FROM ANY OBLIGATIONS UNDER THE WARRANTY AND STATUTORY WARRANTY.
- ! THIS UNIT IS NOT INTENDED FOR USE BY PERSONS, INCLUDING CHILDREN, WITH REDUCED PHYSICAL, SENSORY OR MENTAL CAPABILITIES, OR WITHOUT EXPERIENCE AND KNOWLEDGE, UNLESS THEY ARE SUPERVISED OR HAVE BEEN INSTRUCTED IN THE USE OF THE UNIT BY A PERSON RESPONSIBLE FOR THEIR SAFETY.
- ! CHILDREN MUST BE SUPERVISED TO ENSURE THAT THEY DO NOT PLAY WITH THE UNIT.
- ! CLEANING AND USER MAINTENANCE MUST NOT BE CARRIED OUT BY CHILDREN WITHOUT SUPERVISION.
- ! THE UNIT MUST BE USED IN ACCORDANCE WITH ITS INTENDED PURPOSE AND WITHIN THE OPERATING PARAMETERS FOR WHICH IT HAS BEEN DESIGNED. IN THE EVENT OF IMPROPER USE, THE MANUFACTURER SHALL NOT BE HELD LIABLE FOR ANY RESULTING CONSEQUENCES.



DANGER

ELECTRICAL INSTALLATIONS

- ! ALL ELECTRICAL WORK MUST BE CARRIED OUT BY A LICENSED ELECTRICIAN HOLDING AT LEAST AN E1 QUALIFICATION CERTIFICATE FOR THE OPERATION OF EQUIPMENT, INSTALLATIONS AND NETWORKS, AND A D1 QUALIFICATION CERTIFICATE FOR THE SUPERVISION OF EQUIPMENT, INSTALLATIONS AND NETWORKS.
- ! IF THE UNIT IS EQUIPPED WITH COMPONENTS OR CONNECTED TO INSTALLATIONS THAT REQUIRE E2 AND D2 QUALIFICATIONS, THE INSTALLER AND THE TECHNICAL SUPERVISOR MUST HOLD SUCH QUALIFICATIONS.
- ! CONNECTIONS MUST BE MADE IN ACCORDANCE WITH THE GUIDELINES PROVIDED IN THIS DOCUMENT.
- ! MAKE SURE THAT THE MAINS SUPPLY VOLTAGE COMPLIES WITH THE INFORMATION PROVIDED ON THE RATING PLATES OF THE ELECTRICAL DEVICES. THE PERMISSIBLE DEVIATIONS ARE:
 - o SUPPLY VOLTAGE: +/- 5%
 - o FREQUENCY: +/- 2%
- ! IT IS ALSO RECOMMENDED TO CHECK THAT ALL EARTHING CONDUCTORS ARE PROPERLY SECURED.
- ! A DEDICATED CIRCUIT AND A MAIN SWITCH WITH A LOCKING DEVICE MUST BE INSTALLED. BEFORE STARTING ANY SERVICE OR MAINTENANCE WORK, SET THE MAIN DISCONNECT SWITCH TO THE OFF POSITION.
- ! INCORRECT WIRING OR INSTALLATION MAY CAUSE FIRE OR ELECTRIC SHOCK.
- ! DO NOT USE A DAMAGED OR INCORRECTLY SELECTED SWITCH OR CABLE.



WARNING

CAUTION! HOT PARTS

- ! THE UNIT CONTAINS COMPONENTS WHOSE SURFACE TEMPERATURE MAY BE HIGH, SUCH AS HEAT EXCHANGERS, HEATERS OR THE MOTOR HOUSING. DIRECT CONTACT WITH THESE PARTS MAY RESULT IN BURNS OR OTHER INJURIES. SPECIAL CARE MUST BE TAKEN, APPROPRIATE PROTECTIVE CLOTHING MUST BE WORN, AND SERVICE WORK MAY ONLY BE STARTED ONCE THEIR TEMPERATURE HAS FALLEN BELOW 40°C.

CAUTION! SHARP EDGES

- ! THE UNIT CONTAINS SHARP EDGES, FOR EXAMPLE HEAT EXCHANGER FINS. CONTACT WITH THEM MAY RESULT IN CUTS. THEREFORE, SPECIAL CARE MUST BE TAKEN AND PROTECTIVE CLOTHING MUST BE WORN.

CAUTION! MOVING PARTS

- ! THE UNIT CONTAINS MOVING PARTS, SUCH AS FAN IMPELLERS. CONTACT WITH THEM MAY RESULT IN CUTS OR SERIOUS INJURY. SERVICE WORK MAY ONLY BE STARTED AFTER THESE PARTS HAVE COME TO A COMPLETE STOP.
- ! OPENING INSPECTION PANELS WHILE THE AIR HANDLING UNIT IS OPERATING, OR STARTING THE UNIT WITH INSPECTION PANELS OPEN, IS STRICTLY PROHIBITED.
- ! BEFORE OPENING THE INSPECTION PANELS, SWITCH OFF THE AIR HANDLING UNIT AND WAIT FOUR MINUTES FOR ALL MOVING PARTS TO COME TO A COMPLETE STOP.



WARNING

RESIDUAL RISK

DURING THE DESIGN AND MANUFACTURING PROCESS OF THE UNITS, THE RISK TO PEOPLE AND PROPERTY HAS BEEN MINIMISED. NEVERTHELESS, A CERTAIN LEVEL OF RISK MAY STILL OCCUR WHICH IS BEYOND THE MANUFACTURER'S CONTROL:

- **HAZARDS RESULTING FROM INCORRECT INSTALLATION AND ASSEMBLY:**
 - INSTALLATION IN LOCATIONS ACCESSIBLE TO UNAUTHORISED PERSONS, WHICH MAY CREATE A RISK TO HEALTH AND LIFE.
 - INSTALLATION IN LOCATIONS WHERE SERVICE WORK IS DIFFICULT OR DANGEROUS TO HEALTH OR LIFE.
 - ACCUMULATION AND LEAKAGE OF CONDENSATE, WHICH MAY LEAD TO PROPERTY DAMAGE, ELECTRICAL SHORT CIRCUITS OR SLIPPERY SURFACES.
 - LEAKAGE OF REFRIGERANT OR HEATING MEDIUM FROM THE CIRCUIT, CREATING A RISK TO HEALTH AND LIFE AND CAUSING PROPERTY DAMAGE.
 - FALLING OF A UNIT INSTALLED ON AN UNSUITABLE SUPPORT STRUCTURE, CREATING A RISK TO HEALTH AND LIFE AND CAUSING PROPERTY DAMAGE.
- **HAZARDS RESULTING FROM INCORRECT TRANSPORT:**
 - FALLING OR TIPPING OVER OF THE TRANSPORTED UNIT OR ITS COMPONENTS, CREATING A RISK TO HEALTH AND LIFE AS WELL AS TO PROPERTY.
- **HAZARDS RESULTING FROM INCORRECT STORAGE:**
 - STORAGE UNDER CONDITIONS THAT MAY LEAD TO DAMAGE, DEFORMATION OR CHANGES IN THE PROPERTIES OF THE UNIT OR ITS COMPONENTS, AS A RESULT OF WHICH THE UNIT MAY OPERATE INCORRECTLY OR FAIL TO MEET THE DECLARED REQUIREMENTS.
- **HAZARDS RESULTING FROM INCORRECT ELECTRICAL INSTALLATION:**
 - SHORT CIRCUITS, FIRES AND THE RELEASE OF TOXIC FUMES, WHICH CONSTITUTE A REAL RISK TO HEALTH AND LIFE AND MAY LEAD TO PROPERTY DAMAGE.
 - OPERATION OF THE UNIT WITHOUT FITTED PANELS AND PROTECTIVE GUARDS:
 - CONTACT WITH MOVING OR HOT PARTS MAY CREATE A RISK TO HEALTH AND LIFE.



WARNING

FAULTS, REPAIRS, MODIFICATIONS

- ! IF A FAULT OR INCORRECT OPERATION OF THE UNIT IS DETECTED, THE UNIT MUST BE SWITCHED OFF IMMEDIATELY AND AN AUTHORISED SERVICE PROVIDER MUST BE CONTACTED.
- ! ALL REPAIRS MUST BE CARRIED OUT BY THE MANUFACTURER'S AUTHORISED SERVICE PROVIDER, USING ORIGINAL SPARE PARTS.
- ! ROUTINE INSPECTIONS CARRIED OUT BY QUALIFIED TECHNICAL PERSONNEL OR BY A VTS-AUTHORISED SERVICE PROVIDER ENSURE LONG-TERM, RELIABLE AND TROUBLE-FREE OPERATION OF THE UNITS. OUR SERVICE PERSONNEL ARE AVAILABLE AT ALL TIMES TO PROVIDE SUPPORT DURING COMMISSIONING, MAINTENANCE AND IN THE EVENT OF ANY EMERGENCY SITUATIONS RELATED TO THE OPERATION OF THE UNIT.
- ! VTS-AUTHORISED SERVICE STATIONS SELL SPARE PARTS AND ACCESSORIES FOR OUR AIR HANDLING UNITS. WHEN ORDERING PARTS, PLEASE PROVIDE THE AIR HANDLING UNIT TYPE, SIZE AND SERIAL NUMBER.



INFORMATION FOR USERS ON THE PROPER HANDLING OF WASTE ELECTRICAL AND ELECTRONIC EQUIPMENT (WEEE).

WITH REFERENCE TO EUROPEAN UNION DIRECTIVE 2002/96/EC OF 27 JANUARY 2003 AND THE RELATED NATIONAL REGULATIONS, PLEASE NOTE THAT:

- ! WASTE ELECTRICAL AND ELECTRONIC EQUIPMENT (WEEE) MUST NOT BE DISPOSED OF AS MUNICIPAL WASTE. SUCH WASTE MUST BE COLLECTED AND DISPOSED OF SEPARATELY.
- ! PUBLIC OR PRIVATE WASTE COLLECTION SYSTEMS SPECIFIED IN LOCAL REGULATIONS MUST BE USED.
- ! THE EQUIPMENT MAY CONTAIN HAZARDOUS SUBSTANCES. IMPROPER USE OR INCORRECT DISPOSAL OF SUCH SUBSTANCES MAY HAVE A NEGATIVE IMPACT ON HUMAN HEALTH AND THE ENVIRONMENT.
- ! THE SYMBOL OF THE CROSSED-OUT WHEELED BIN, PLACED ON THE PRODUCT, PACKAGING OR TECHNICAL LEAFLET, MEANS THAT THE EQUIPMENT WAS PLACED ON THE MARKET AFTER 13 AUGUST 2005 AND MUST BE DISPOSED OF SEPARATELY.
- ! BY SORTING AND HANDING OVER WASTE ELECTRICAL AND ELECTRONIC EQUIPMENT FOR PROCESSING, RECOVERY, RECYCLING AND DISPOSAL, YOU PROTECT THE ENVIRONMENT AGAINST POLLUTION AND CONTAMINATION, HELP REDUCE THE USE OF NATURAL RESOURCES AND LOWER THE COST OF MANUFACTURING NEW EQUIPMENT.
- ! IN THE EVENT OF ILLEGAL DISPOSAL OF ELECTRICAL AND ELECTRONIC WASTE, PENALTIES ARE SPECIFIED IN LOCAL WASTE DISPOSAL REGULATIONS.



DANGER



EMERGENCY SITUATIONS – FIRE

PROCEDURE IN THE EVENT OF A FIRE INVOLVING ELECTRICAL EQUIPMENT:

KEEP CALM - DO NOT PANIC, ASSESS THE SITUATION.

DISCONNECT THE POWER SUPPLY:

- IF POSSIBLE, CUT OFF THE POWER SUPPLY, E.G. BY SWITCHING OFF THE FUSES OR THE MAIN SWITCH.
- DO NOT TOUCH THE UNIT OR CABLES WITH BARE HANDS, AS THEY MAY STILL BE LIVE.

CALL FOR HELP:

- CALL THE EMERGENCY NUMBER.
- PROVIDE THE EXACT ADDRESS AND A BRIEF DESCRIPTION OF THE SITUATION.

EXTINGUISHING THE FIRE:

DO NOT USE WATER! WATER CONDUCTS ELECTRICITY AND MAY CAUSE ELECTRIC SHOCK.

- USE SUITABLE FIRE-FIGHTING EQUIPMENT:
 - CO₂ FIRE EXTINGUISHER, CARBON DIOXIDE, RECOMMENDED FOR EXTINGUISHING LIVE ELECTRICAL EQUIPMENT.
 - ABC POWDER FIRE EXTINGUISHER, MAY BE USED, BUT MAY DAMAGE ELECTRONIC COMPONENTS.

EVACUATION:

- IF THE FIRE IS SERIOUS OR CANNOT BE EXTINGUISHED SAFELY, LEAVE THE ROOM AND CLOSE THE DOOR BEHIND YOU TO LIMIT THE OXYGEN SUPPLY.
- HELP OTHERS LEAVE THE BUILDING.
- DO NOT USE LIFTS.

IN THE EVENT OF A FIRE, there is a risk to health and life due to high temperature, heavy smoke and the release of harmful gases, including carbon monoxide, carbon dioxide, hydrogen chloride, hydrogen cyanide and dioxins.

! THE USE OF RESPIRATORY PROTECTIVE EQUIPMENT (RPE) IS REQUIRED!

2 GENERAL INFORMATION

Thorough familiarisation with the contents of this manual, as well as the installation, commissioning and operation of the air handling unit according to the instructions given and in compliance with all health and safety regulations will guarantee a solid basis for efficient, safe and trouble-free operation of the unit.

This document does not cover all possible configurations of these units, does not give all examples of their assembly and installation, nor does it discuss all aspects of their commissioning, operation, repair and maintenance. When the equipment is used in accordance with its design purpose, both this documentation and any other material that accompanies the supplied equipment contain information intended for qualified technical personnel only.











- ! The installation, commissioning and servicing of air handling units and their equipment may involve certain safety risks and therefore require specific knowledge and training.
- ! Equipment improperly installed, adjusted, or repaired by a person without the required qualifications can become the cause of serious injury to individuals or even their death. The above relieves the manufacturer of liability and benefits under the warranty and guarantee.
- ! When connecting, servicing and operating air handling units, all precautions communicated by the manufacturer and those arising from good practice in the field of HVAC installations and equipment.
- ! Installation, maintenance and repairs must be carried out by qualified technical personnel or supervised by authorised specialists.
- ! Qualified technical personnel are understood to be trained specialists who, through their professional experience, knowledge of the relevant standards, documentation and regulations relating to operating procedures and associated safety, are authorised to carry out the necessary activities, and those who are able to diagnose and rectify any potential problems.
- ! Warranty repairs of VTS air handling units may be carried out only by service employees with authorisations granted by VTS, confirmed by an appropriate certificate, allowing them to perform this kind of work. We also recommend that the service staff authorised by VTS carry out assembly, start-ups and post-warranty repairs, technical inspections and maintenance works which are required to be performed on air handling units.
- ! VTS reserves the right to make changes without prior notice.

VENTUS COMPACT HP floor mounted AHU with heat pump (AHUs - air handling units) can be installed either indoors or outdoors. The low height of the unit makes the units fit perfectly into standard ceiling voids or spaces above the suspended ceiling. The units are designed to work with air duct systems supplying and extracting air from rooms according to the ventilation design for the parameters indicated in the unit selection sheet. The duct connection ensures that there is no access to the rotating parts of the unit (fan impeller). Nominal unit parameters are presented in the unit selection sheet. Installation of the unit outdoors requires the use of roofing and air intakes and outlets respectively, as well as protection of peripheral automatic components against weather conditions.

!

- ! IT IS STRICTLY FORBIDDEN TO OPEN THE INSPECTION PANELS WHILE THE AIR HANDLING UNIT IS IN OPERATION OR TO START UP THE AIR HANDLING UNIT WITH THE INSPECTION PANELS OPEN.
- ! SWITCH OFF THE CONTROL UNIT AND WAIT TWO MINUTES FOR ALL ELEMENTS IN MOTION TO STOP BEFORE OPENING THE INSPECTION PANELS.
- ! DISCONNECT AND SECURE THE POWER SUPPLY TO PREVENT UNCONTROLLED START-UP OF THE CONTROL PANEL.
- ! AN CONTROLS SYSTEM IS REQUIRED TO ENSURE CONTROL OF OPTIMAL OPERATION OF THE UNIT AND TO PROTECT THE UNIT AGAINST FAILURE. THE AUTOMATICS MUST INDICATE THE DEGREE OF DIRTINESS OF THE AIR FILTERS.

The unit can be equipped with a number of duct functions and accessories as well as an Controls system. The unit functions and their parameters are given in the selection sheet generated from the manufacturer's IT system according to the design guidelines.

FUNCTION			FUNCTIONAL VERSIONS			
F	Air filter		Air filter initial		Air filter secondary	
V	Fan					
H	Heater		Heater Water		Heater Electric	
S	Noise attenuator					
E	Empty section					

OTHER DESIGNATIONS IN THE CONTROL PANEL

AD	Air damper	
FLX.CON	Flexible duct connection	
IN	Inlet (feed e.g. medium)	
OUT	Outlet (return e.g. medium)	

VENTUS COMPACT HP units have inspection panels located at the front of the unit.

BASE SECTION

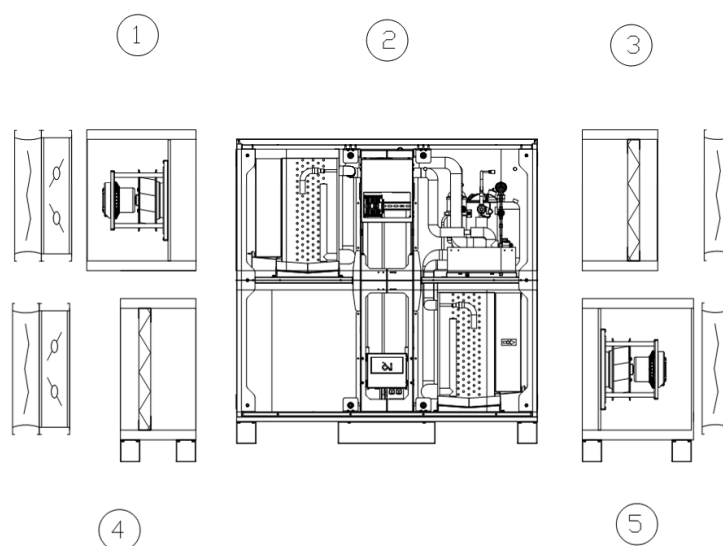

1	Exhaust fan section
2	Recovery section: rotary heat exchanger and heat pump
3	Exhaust air filter
4	Supply air filter
5	Supply fan

The units can be manufactured as right-sided or left-sided. The orientation of the unit is determined by the direction of airflow in the supply (bottom) path relative to the side of the unit where the inspection panels are located.

**MARKING OF THE AIR INLET AND OUTLET OF THE AIR HANDLING UNIT
INSPECTION SIDE VIEW - RIGHT-HAND VERSION**

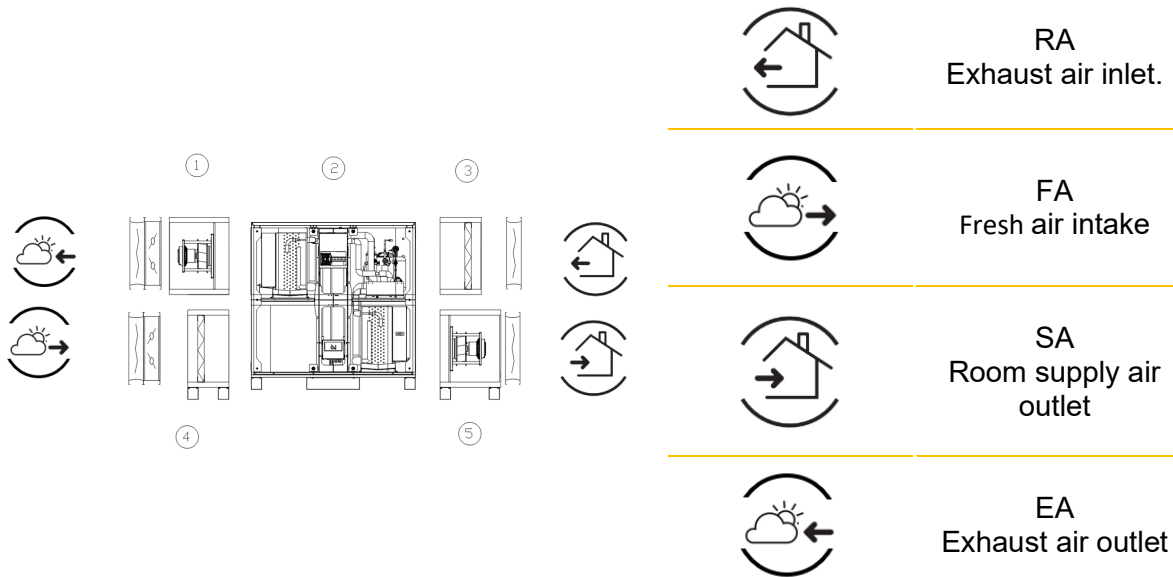

**MARKING OF THE AIR INLET AND OUTLET OF THE AIR HANDLING UNIT
INSPECTION SIDE VIEW - LEFT-HAND DESIGN**

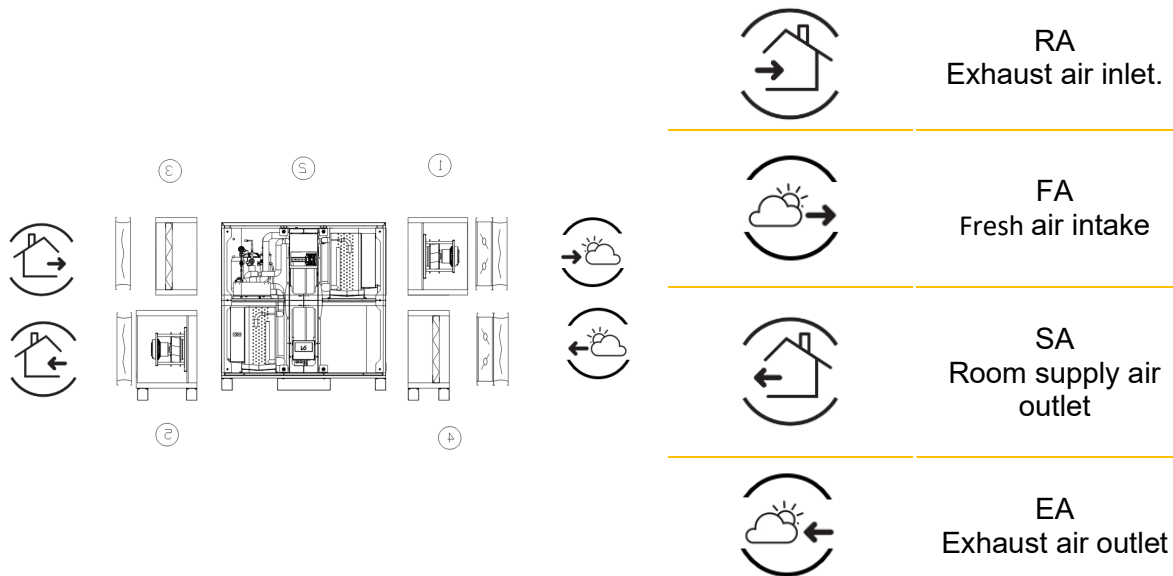

3 HEAT PUMP SYSTEM

The heat pump is a pressurised system built inside the air handling unit. It is a reversible system with direct evaporation, which consists of: a DX evaporator, a DX condenser, a compressor, a DX tank and complete refrigeration fittings. The heat pump is designed to cool or heat the supply air to the space depending on the control setting resulting from the operating mode and the current demand of the installation (room).

HEAT PUMP SYSTEM DIAGRAM

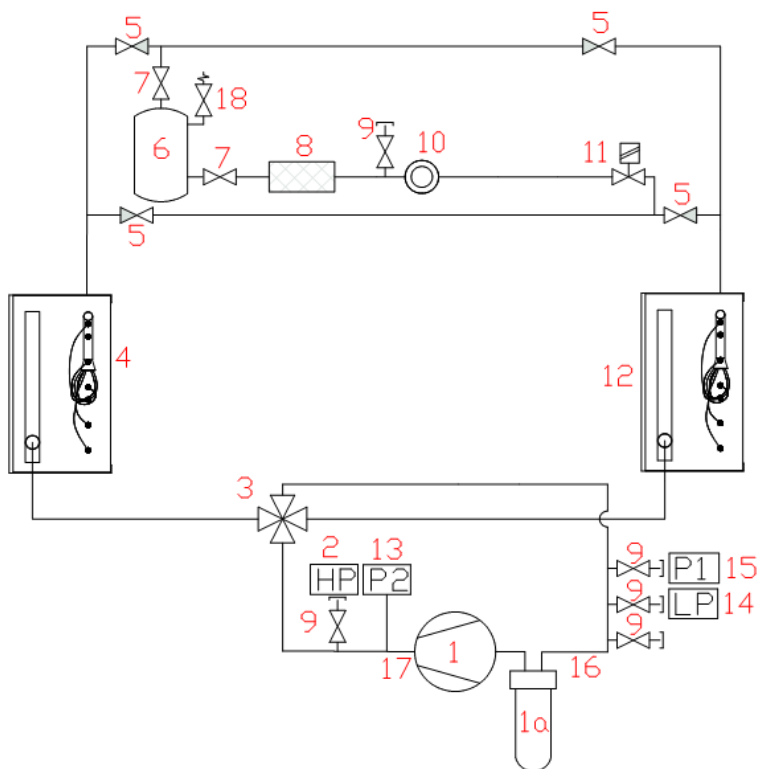

- | | |
|----|---------------------------------------|
| 1 | Compressor |
| 1a | Liquid separator |
| 2 | High pressure switch |
| 3 | 4-way valve |
| 4 | Evaporator (Condenser) |
| 5 | Non-return valve |
| 6 | Liquid refrigerant tank |
| 7 | Service shut-off valve (Rotalock) |
| 8 | Filter-drier |
| 9 | Shut-off valve |
| 10 | Viewfinder |
| 11 | Electrically operated expansion valve |
| 12 | Condenser (Evaporator) |
| 13 | High pressure transducer |
| 14 | Low pressure transducer |
| 15 | Low pressure switch |
| 16 | Suction temperature sensor |
| 17 | Discharge temperature sensor |
| 18 | Safety valve |



- ! Reversible heat pump system designed to operate with R410A refrigerant.
- ! For units equipped with a freon installation - check the applicable regulations relating to the obligations of the installer, owner/operator of the heat pump or DX installation before installing the unit (see F-Gas Act).
- ! The refrigerant must not be released into the atmosphere! If the addition or extraction of refrigerant is required, then the service technician performing this operation must comply with all local, national, EU and industry regulations.
- ! The owner of the heat pump or the owner (operator) of the DX plant is required to set up and register an Appliance Card in which all inspections, repairs or modifications to the appliance are recorded.

CENTRAL	COMPRESSOR	IL. ROWS OF THE SUPPLY AIR EXCHANGER	IL. ROWS OF EXHAUST EXCHANGER	QUANTITY R410A [KG]	OPTION TO SUPPORT HEAT PUMP OPERATION WITH INTEGRATED HEATER
VVS021c	C-6RZ210H1BDF	6	6	5,2	4kW (below -17° C)
VVS021c	C-6RZ210H1BDF	4	6	4,8	4kW (below-17° C)
VVS030c	C-6RZ210H1BDF	6	6	6	6kW (below -16° C)
VVS030c	C-6RZ210H1BDF	4	6	5,5	6kW (below-16° C)
VVS040c	ATF400	6	6	7,4	
VVS040c	ATF400	4	6	7,4	
VVS055c	ATF400	6	6	9,2	
VVS055c	ATF400	4	6	9,2	
VVS075c	ATQ580	6	6	13,4	
VVS075c	ATQ580	4	6	13,4	

CHARACTERISTICS OF R410A

Name:	Mixture of Difluoromethane- pentafluoroethane (50%-50%)
Designation	R410A
Safety class (EN 378-1:2017)	A1
Fluid category (97/23/EC PED)	2
Corrosive properties	Does not cause corrosion
GWP100 [CO2 equivalent].	2088

COMPRESSOR OPERATING ENVELOPE

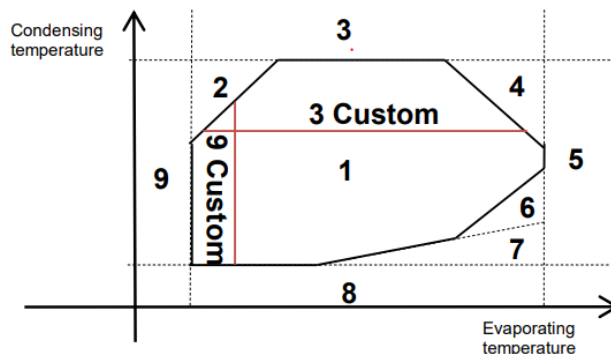

DESCRIPTION OF COMPRESSOR WORK ZONES

- 1 Zone inside the operating limits (protection function is activated to avoid exceeding the limits)
- 2 Maximum compression ratio
- 3 Maximum condensing pressure
Maximum non-standard threshold value of condensing pressure

DEDICATED AREAS

- 4 Maximum motor current
- 5 Maximum evaporation pressure
- 6 Minimum compression ratio
- 7 Minimum differential pressure
- 8 Minimum condensing pressure
- 9 Minimum evaporation pressure
- 9 Custom Minimum non-standard threshold value of condensing pressure

RATED COMPRESSOR PERFORMANCE			
COMPRESSOR	C-6RZ210H1BDF	ATF400	ATQ580
Number of compressors	1	1	1
Compressor type	Hermetic rotary	Hermetic rotary	Hermetic rotary
Power supply	Inverter	Inverter	Inverter
Displacement volume [cm ³]	21	39,8	57,9
Cooling capacity [kW]	14	30	35
Refrigerant	R410A	R410A	R410A
Rated current	9.8A	16.7A	17.8A
Engine type	BLDC	BLDC	BLDC
Speed [1/s]	8-120	12-120	12-120

3.1 HEAT PUMP CONTROL

VENTUS COMPACT HP units are pre-wired at the factory and are equipped with advanced control and protection Controls. The Controls system is based on built-in and integrated controllers: uPC3 and C.CPCO MINI which ensures complete control and protection of the unit together with the heat pump system (system: OSSTDmCOMN).

The uPC3 integrated control system handles all control, protection and regulation functions of the entire air handling unit, while the OSSTDmCOMN control system provides protection and performance control of the inverter compressors. The heating or cooling function is automatically activated based on the set point and demand of the air handling unit via a control signal transmitted over the Modbus protocol.

Temperature control is carried out in sequence:

1. Pre-heater (optional)
2. Rotary exchanger
3. Heat pump
4. Secondary heater (optional)

When there is a demand for heating or cooling, the main control unit of the air handling unit sends a heating or cooling demand signal and an operating start signal.

3.1.1 EXCHANGER DEFROSTING

DEFROSTING PROCEDURE

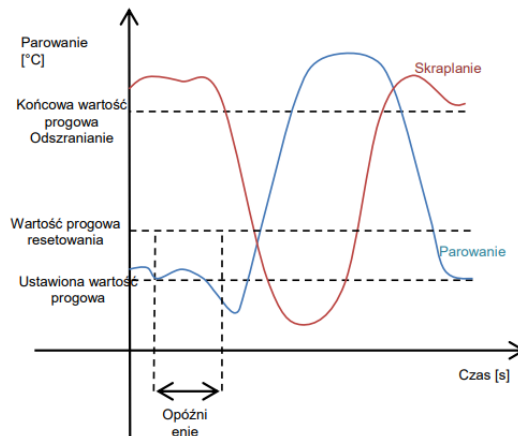

Description of the heat pump defrosting process:

- | | |
|--|--|
| <ul style="list-style-type: none"> • Exceeded Min Vapour Pressure Threshold • Delayed activation of defrost mode • Activation of defrost mode, display on the controller • Reduction in compressor power when entering the defrost phase • Switching the 4-way valve to supply air cooling mode | <ul style="list-style-type: none"> • Increase in compressor power when entering the defrost phase • Defrosting process • Reduction in compressor power when leaving the defrost phase • Dehydration phase • Switching the 4-way valve to supply air heating mode • Increase of compressor power when leaving the defrosting phase to the level before defrosting |
|--|--|

A heating element has been placed under the evaporator in the drip tray to prevent the accumulation of ice during the defrost procedure. In heating mode, the evaporator in the exhaust air must be defrosted when operating at low outside temperatures. An advanced function for detecting ice accumulation on the exchanger and a hot refrigerant vapour defrost procedure is available in the integrated control system.

3.1.2 FAILURE PROTECTION SYSTEM

The field control function is integrated into the internal control system. This prevents exceeding the safe conditions for any of the components. Signals from the high and low pressure transducers provide information to ensure maximum performance without exceeding the set value. This prevents interruption of cooling or heating by the high and low pressure switches. The control system ensures maximum recovery capacity at set airflows and outdoor air and exhaust air temperatures.

Compressor operation protection is implemented by:

- controls algorithm,
- low pressure prestostat (limiter),
- high pressure presotate (limiter),
- safety valve.



- ! The occurrence of an alarm condition is signalled on both the main panel controller and the heat pump controller.
- ! In the event of an emergency stop of the air handling unit, the heat pump does not receive a start signal. Signalling and resetting of the heat pump alarms is carried out from the control panel of the air handling unit.
- ! The control system is equipped with functions to protect the heat pump from damage in the event of a power outage and in the event of a long standstill of the heat pump with the unit running.
- ! In the event of a power failure of the heat pump or in the event of a long standstill, the expansion valve is opened, which causes the liquid refrigerant to accumulate at the coolest point of the entire system. On first start-up, after such an event, the heat pump starts up in cooling mode for a time set by the control system.

During shutdown, the heat pump is protected by the safety valve as a pressure element independent of the control system. When the heat pump is in operation, the first safety function is the heat pump control system which, by regulating the compressor speed and the degree of opening of the expansion valve, keeps the compressor in its field (envelope) of operation.

When operating the compressor outside of its proper field of operation, another safety feature is the high and low pressure limiters. The low pressure limiter is fitted upstream of the compressor on the suction side (normally open contact). When the pressure drops to 3.3 bar(g), the safety contacts of the compressor speed controller are disconnected. On pressure increase to 4.8 bar(g), there is an automatic switching of contacts

The high-pressure limiter is fitted after the compressor on the discharge side (normally closed contact). When the pressure rises to 38 bar(g), the safety contacts of the compressor speed controller are disconnected. When the pressure drops to 28 bar(g) there is an automatic contact switching.

4 PREPARATION FOR INSTALLATION

4.1 TRANSPORT AND STORAGE

The air handling units are packaged for easy internal transport and storage at the installation site. Upon delivery of the unit, all components must be checked to ensure that no damage has occurred in transit. Detailed instructions for this are included in the table Checklist on receipt.

Immediately upon receipt of the consignment with the equipment, a check for transport damage must be carried out according to the points in the checklist.

ACCEPTANCE CHECKLIST	
1	All individual packages must be checked before accepting the consignment. Check packaging for damage and completeness according to the consignment note.
2	If any device (package) appears to be damaged, it should be inspected immediately before accepting the entire consignment. Appropriate, damage-related entries should also be made on the consignment note. Delivery should not be refused.
3	Check the appliance immediately after delivery and before storage for concealed damage. Report concealed damage to the carrier within the time limit specified for this purpose from the date of delivery. Check with the carrier its deadline for making a claim.
4	Do not move the damaged appliance from the place to which it was delivered directly from the delivery. It is the responsibility of the recipient of the delivery to provide adequate evidence that the concealed damage did not already occur after delivery.
5	If the unit in question appears to be damaged, stop unpacking it. Save all internal packaging, cartons and cases. If possible, take photographs of the damage.
6	Immediately notify the carrier of the identified damage: by telephone and email in accordance with the procedure. Immediate joint damage control by a joint team of the carrier and consignee of the shipment should be requested.
7	Notify the VTS representative of the damage found and make arrangements for repair. The carrier's representative should inspect the damage before repairing it.
8	Compare the electrical data on the unit's rating plate with that on the order and in the shipping documentation to check that the unit received is correct.



! Any damage caused as a result of incorrect transport, unloading or storage is not covered by the guarantee and any claims submitted for cases of the above nature will not be considered by VTS.

RULES FOR THE TRANSPORT OF CENTRAL SECTIONS

- ! The air handling units must be transported in the position and in the manner marked on the original manufacturer's packaging.

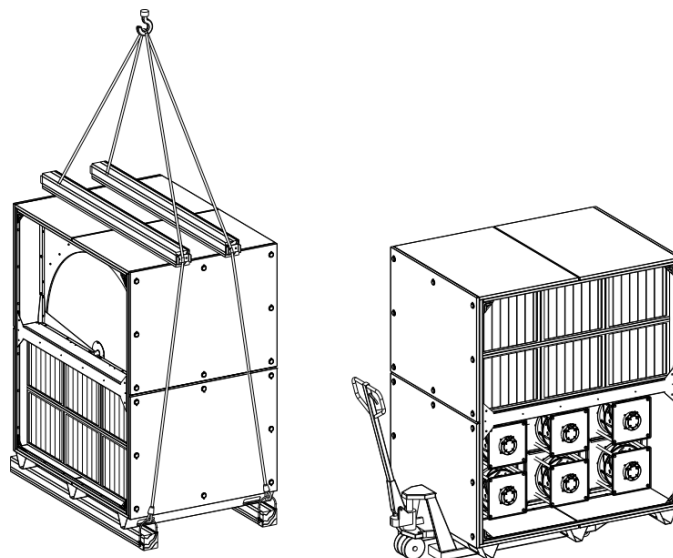

! Equipment packaging:

- should be placed in paved, dry locations protected from precipitation,
- should be placed and stored away from areas with active mechanical equipment (vehicles, cranes and other construction machinery),
- should be stored in places where they will not be exposed to any mechanical damage: moisture, aggressive chemicals, liquids, dust and any other external factors whose influence may impair their technical and functional condition.

VTS recommends leaving the units and their equipment in their transport packaging on pallets for protection and to facilitate proper positioning during installation.



- ! The equipment as well as its components should be:
 - stored in rooms with the following conditions:
 - relative humidity: $\phi < 80 \%$, at $t = (+20) \text{ }^\circ\text{C}$,
 - ambient temperature: $(-40) \text{ }^\circ\text{C} < t < (+60) \text{ }^\circ\text{C}$.
 - protected from contact with corrosive (caustic) dusts, gases or vapour, as well as with any other chemical substances liable to have a corrosive effect on the equipment or its accessories.
- ! The inside of the air handling unit and all unit components, in particular air filters, must be protected against moisture and contamination from the surroundings, such as dust, dirt and other impurities.
- ! The air filters should be stored in their original packaging or in another manner that provides protection against contamination.
- ! All air filters must also be protected against direct sunlight, which may adversely affect the filter media and structural components of the filter. It is recommended to store filters in a dry, clean and shaded place.

4.2 PREPARATION FOR INSTALLATION

Transport of the equipment requires lifting equipment at the installation site. Make sure that once the unit is installed, there will be enough space to properly bring the technological and electrical installations to the unit and to carry out maintenance on the unit without any problems.

4.2.1 LOCATION OF THE DEVICE

Allow adequate space for the placement of piping and electrical connections. All piping and ducting should be fixed independently of the air handling unit to reduce excessive noise and vibration.

RECOMMENDATIONS FOR THE LOCATION OF THE DEVICE

1	The weight of the appliance must be taken into account. When doing so, refer to the weight of the appliance on its rating plate. The weight on the rating plate does not take into account the weight of the media (except R410A), which should be taken into account when installing the unit.
2	Sufficient space should be left to allow for the removal of the enclosure panels and for access for maintenance work.
3	The installer must provide a lifting device to raise the ceiling-mounted optional duct sections.
4	All equipment must be mounted horizontally.
5	Consideration should be given to the requirements for coil and drain pipework and condensate drainage.

4.2.2 INSTALLATION OF VENTUS COMPACT HP

POSITIONING LAYOUT VVS021c (STANDARD DIMENSIONS)

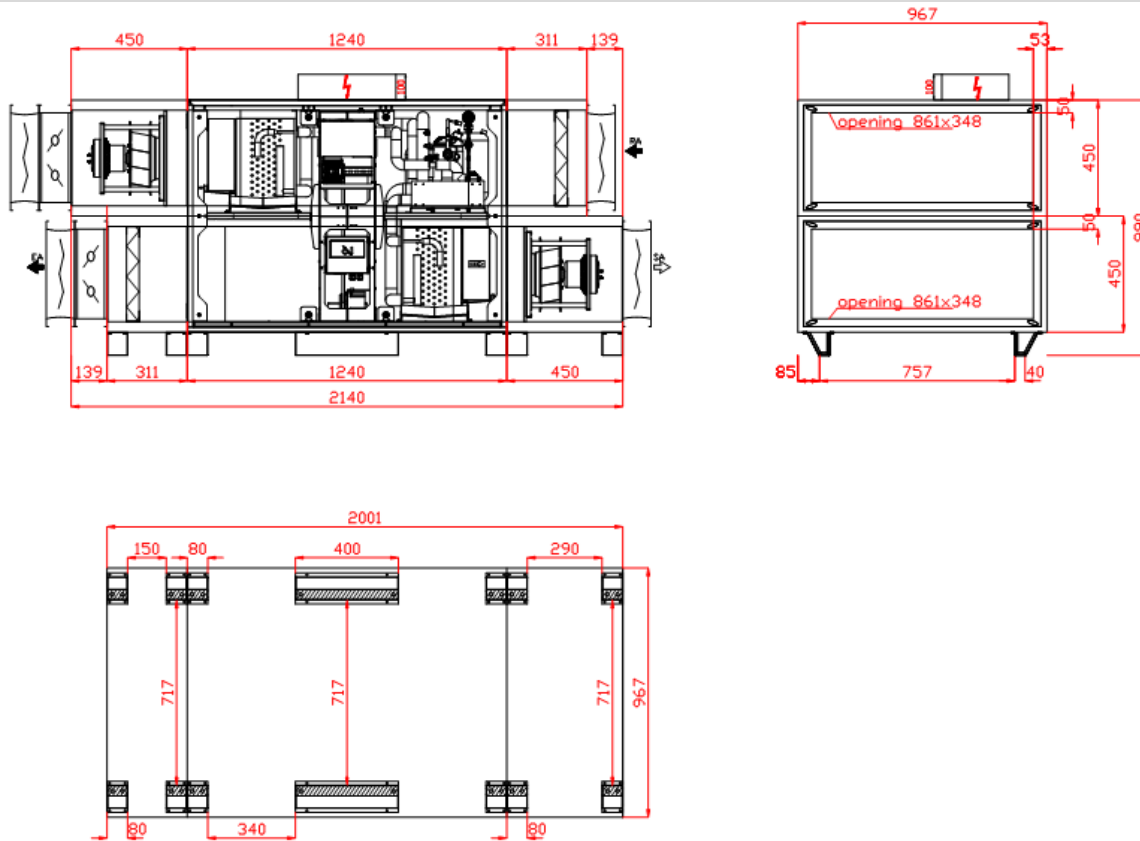

- ! The dimensions of the base block and additional functions are available in the unit's technical data sheet.

VVS030C UNIT POSITIONING LAYOUT (STANDARD DIMENSIONS)

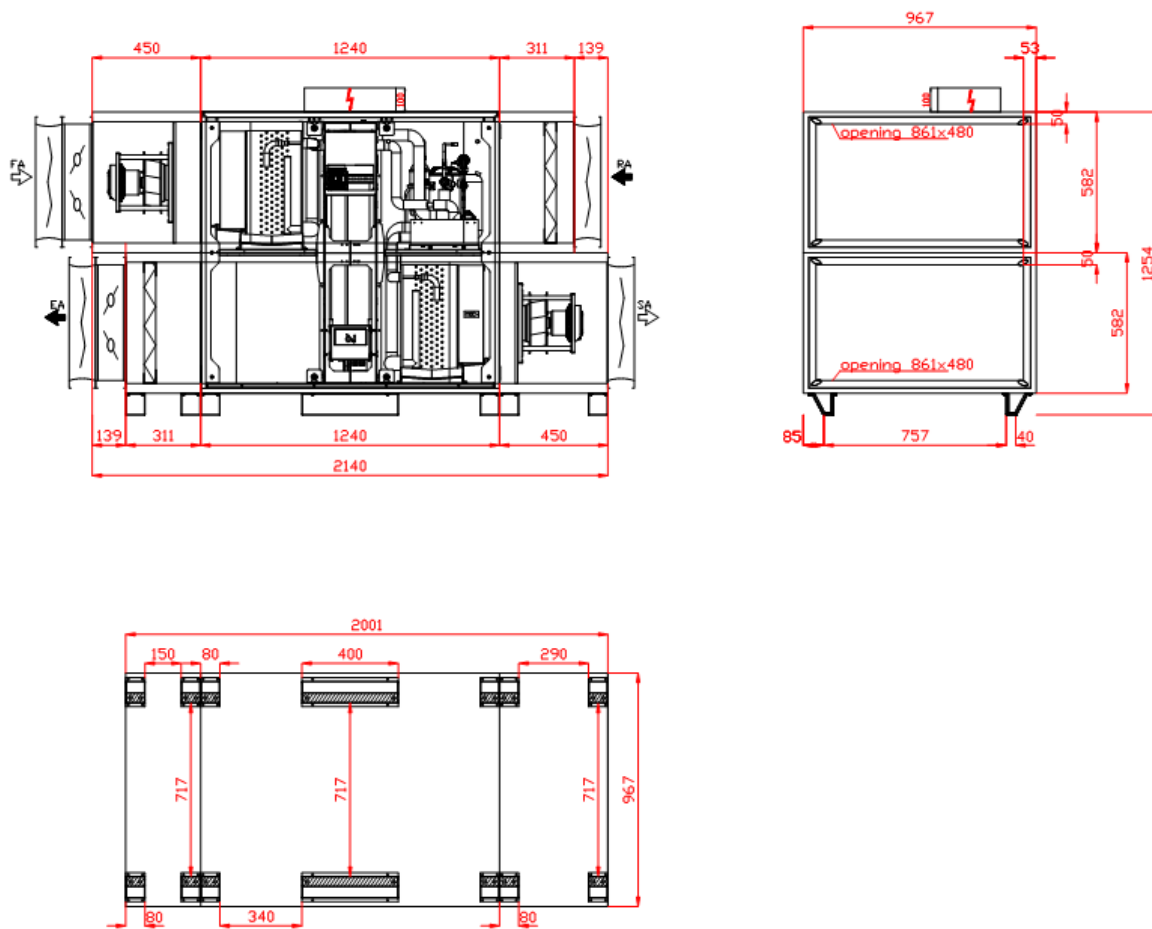

! The dimensions of the base block and additional functions are available in the unit's technical data sheet.

VVS040C UNIT POSITIONING LAYOUT (STANDARD DIMENSIONS)

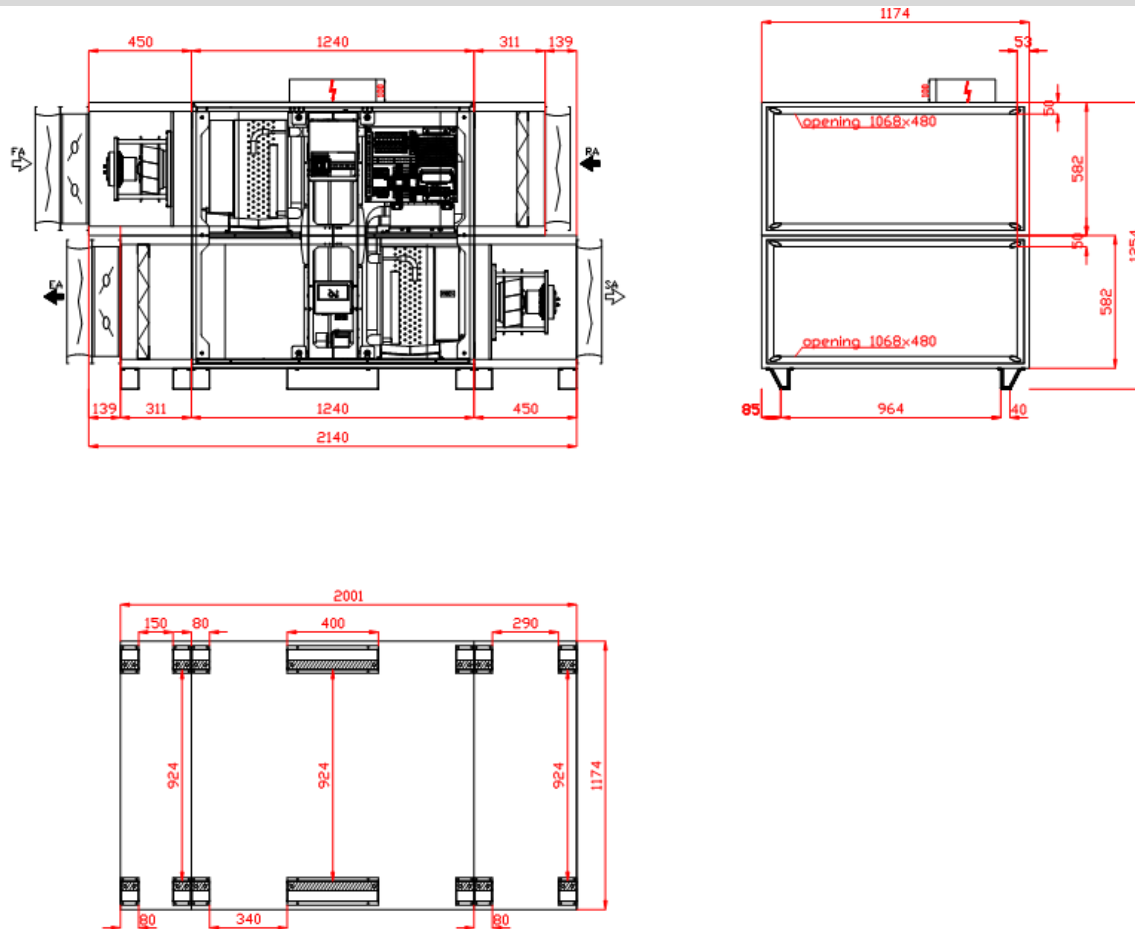

- ! The dimensions of the base block and additional functions are available in the unit's technical data sheet.

VVS055C UNIT POSITIONING LAYOUT (STANDARD DIMENSIONS)

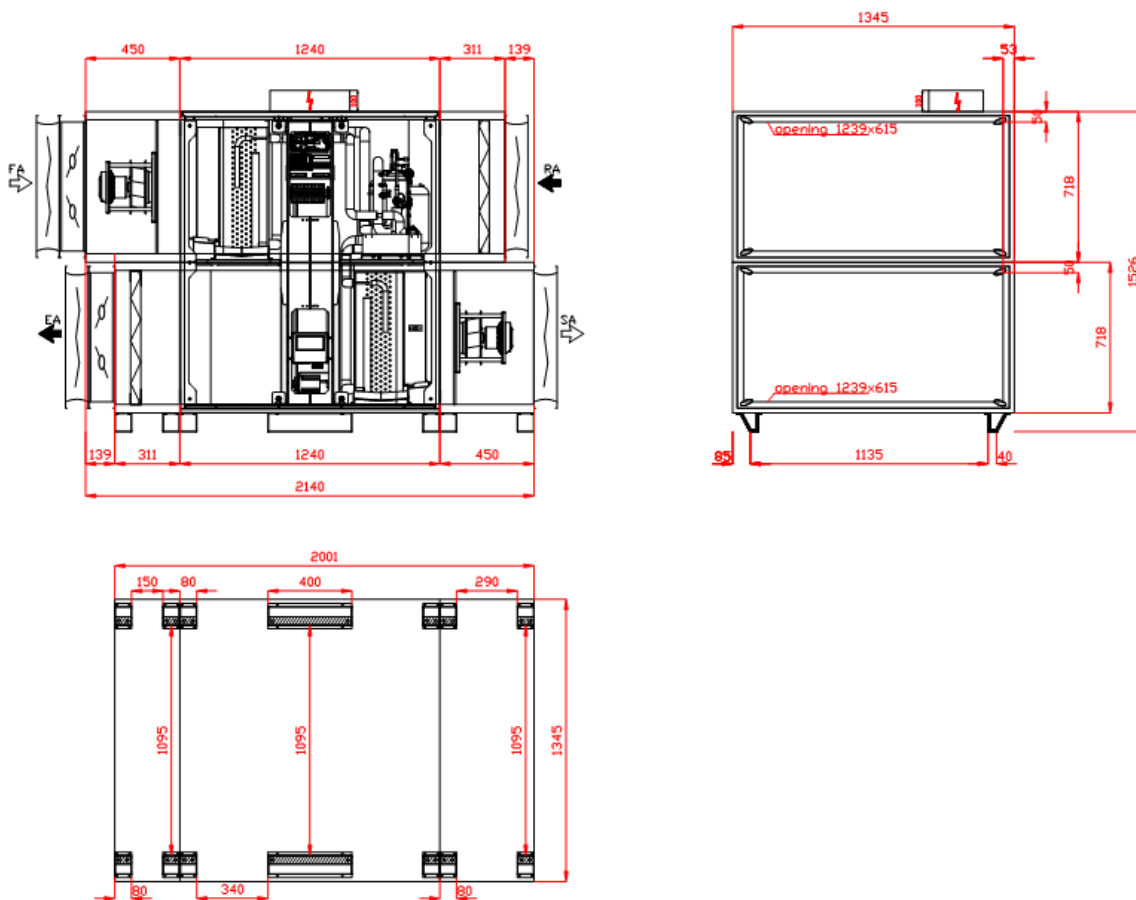

! The dimensions of the base block and additional functions are available in the unit's technical data sheet.

POSITIONING LAYOUT VVS075c (STANDARD DIMENSIONS)

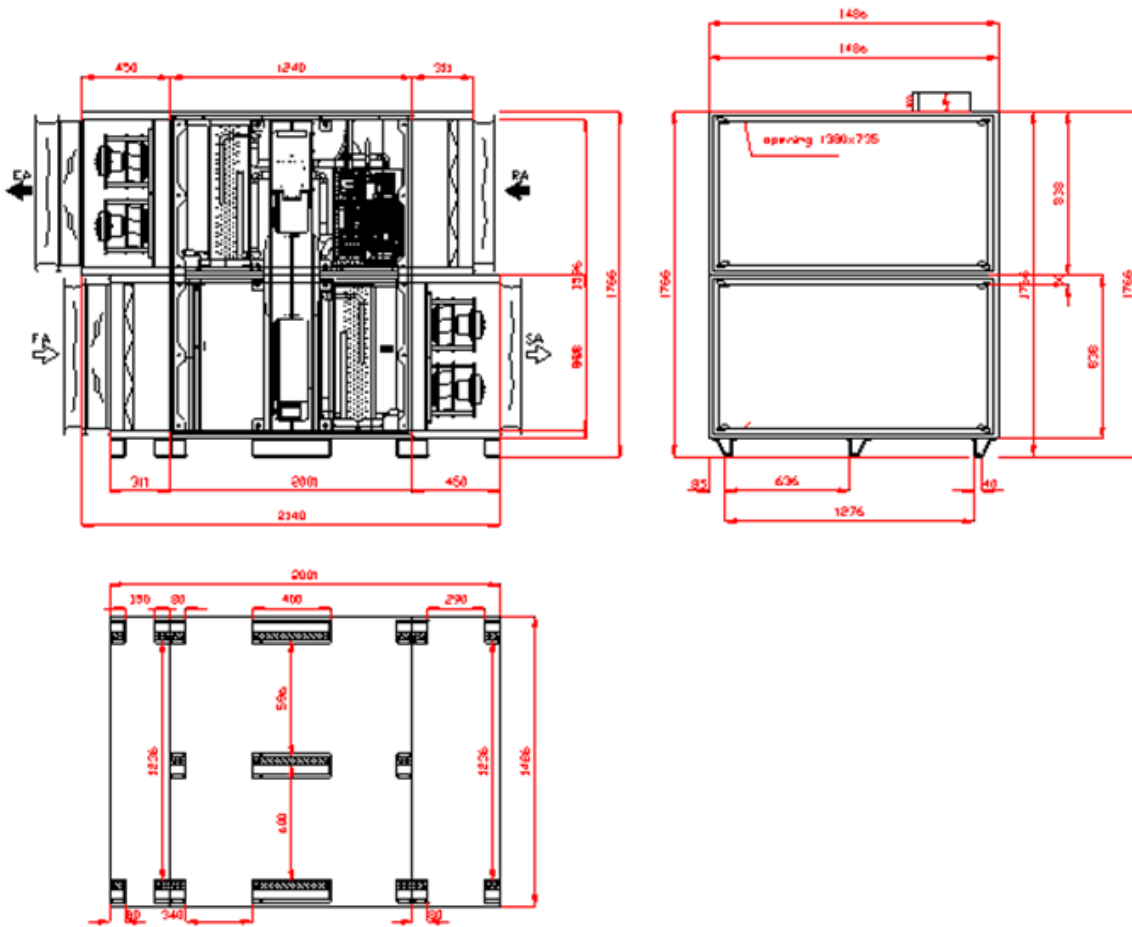

- ! The dimensions of the base block and additional functions are available in the unit's technical data sheet.

FIXING OF THE FRAME/FOOTPLATE TO THE GROUND

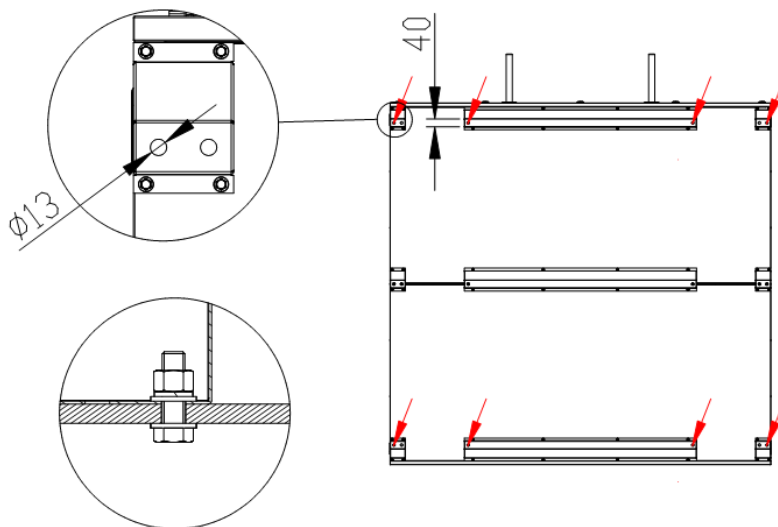

! The frame should be fixed through the extreme holes in the feet/frame.

CONDENSATE DRAINAGE

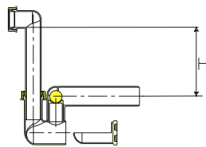

! When planning the foundation of the unit, provision must be made to drain the condensate from the drip trays.

H [mm] = total fan discharge in mm water column ($\text{Pa} \times 0.1$)

! The dimensions of the base block and additional functions are available in the unit's technical data sheet.

4.2.3 CONNECTING AIR DUCTS

INSTALLATION OF AIR DUCTS

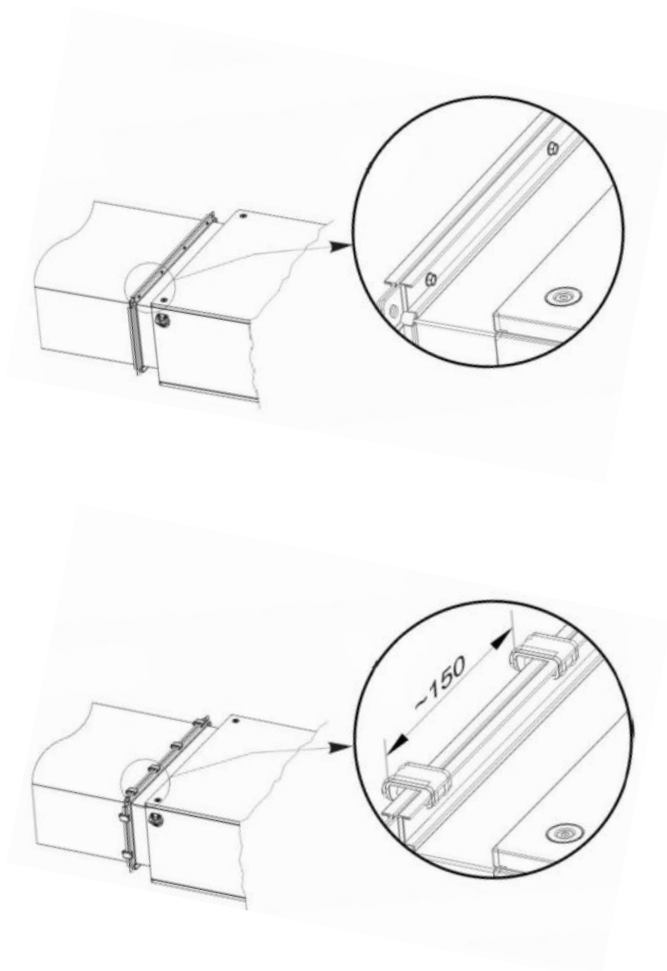

Air ducts should be connected to the air handling unit with flexible connections (optional equipment) that dampen unit vibrations and compensate for misalignment of duct and air handling unit outputs.

Flexible connections are fitted with sealed flanges. Flexible flanges should be connected to the ducts using self-tapping screws or additional clamping elements.

The components used to connect the ducts are not included in the standard delivery.

Air ducts must not support their weight on the air handling unit!

4.2.4 CONNECTING BASE BLOCK SECTIONS

ASSEMBLY OF BASE BLOCK SECTIONS

Łączenie sekcji - krok 1

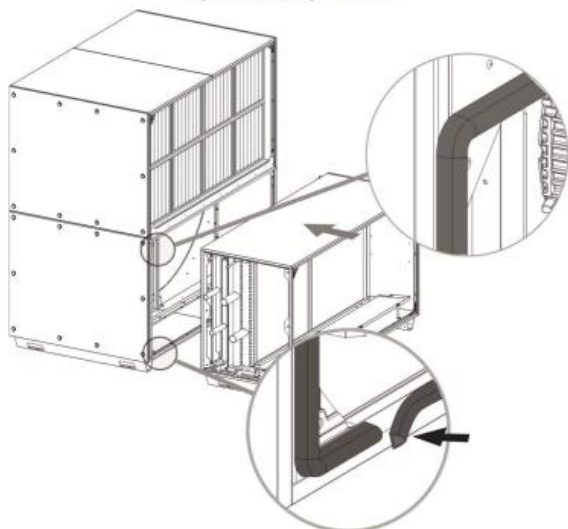

Łączenie sekcji - krok 2

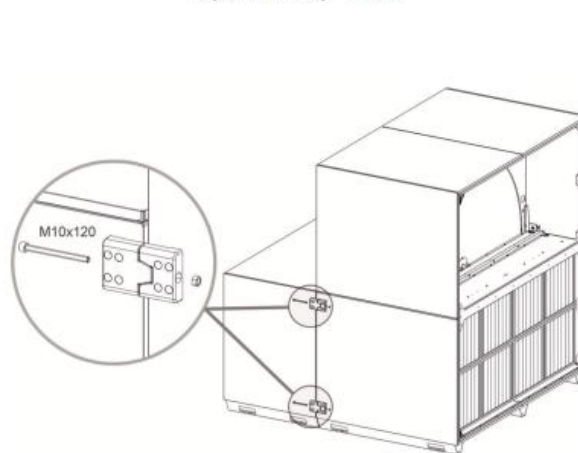

Łączenie sekcji - krok 3

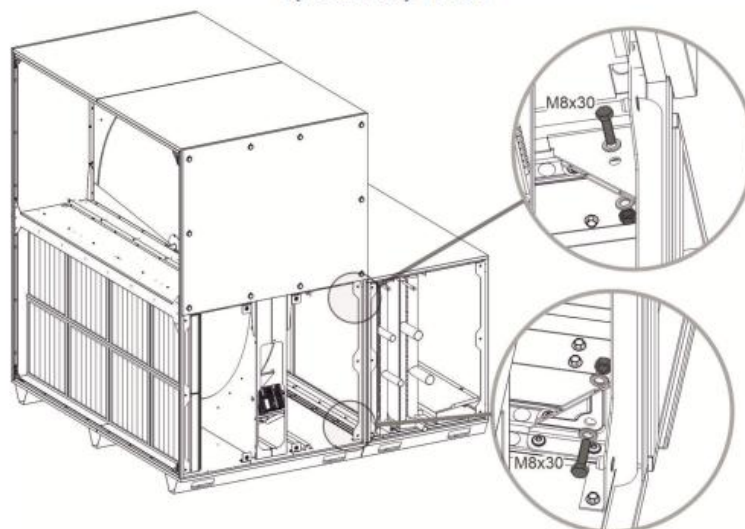

CONNECTING THE CHANNEL MODULE

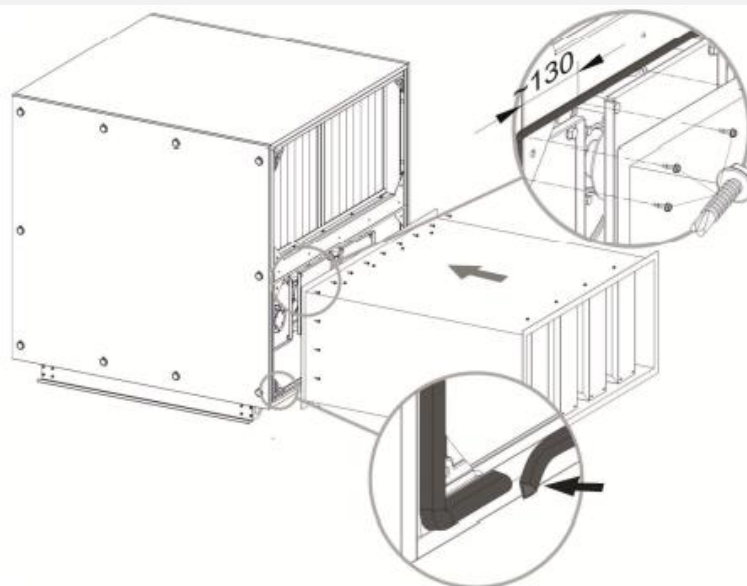

CONNECTING THE FAN SECTION

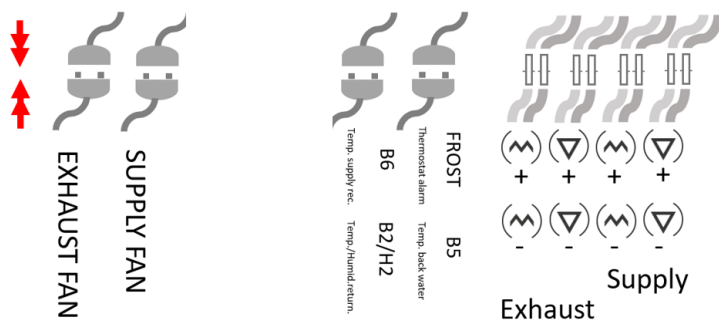

The base configuration of the VENTUS COMPACT HP with heat pump is supplied as a wired unit with the Controls system connected and configured. Using the supplied connectors (electrical cable, pneumatic cable), connect the fan and air filtration sections to the base section (with heat pump).

"+" higher pressure side (red wire), "-" lower pressure side (blue wire),

5 CONNECTION OF WATER HEATER

5.1 CONNECTION OF WATER HEATERS



- ! The unit should be equipped with a water or electric heater (optional) to support the heat recovery (rotary heat exchanger and heat pump) and to provide space heating during the heat pump defrost period. If the unit has a space heating function (without other heating systems) then the optional heater is mandatory to ensure room comfort.
- ! The operation of the water exchanger requires its connection to the process heat system depending on the designed function of this exchanger.
- ! Exchangers must be protected against freezing (if there is a risk of this).
- ! The connection of additional heat exchangers must be carried out in such a way that no stresses are caused which could result in mechanical damage or leaks. The weight of the pipes and thermal stresses must not be transferred to the exchanger connections.
- ! Supply lines should be routed to avoid collision with other sections of the air handling unit and other installations.
- ! It must be possible to easily disconnect the heat exchangers from the process heat installation for maintenance and service work.
- ! Compensation should be used at the inlet and outlet of the joints to compensate for linear expansion of the pipes.
- ! Hydraulic lines must not be routed over electrical lines.

QUALITY REQUIREMENTS FOR THE SUPPLY MEDIUM WATER EXCHANGERS

- ! Oil and grease < 1 mg/l ! pH at (+25) °C 8-9.
- ! Oxygen < 0.1 mg/l (as low as possible).
- ! Minimum radiator temperature (+3) °C.
- ! Maximum operating temperature (+130) °C.
- ! Maximum operating pressure 16 bar.
- ! At sub-zero flow temperatures, a freezing point-lowering additive, e.g. glycol, should be used (up to a maximum of 50% in the mixture).
- ! Water hardness no greater than:
 - normal concentration = 4.101 [mval/l] [mval/dm³]
 - molar concentration = 2.051 [mmol/l] [mmol/dm³].
 - Ca⁺²/l = 82.189 [mg Ca⁺²/l] [mg Ca⁺²/dm³].
 - CaCO₃ = 205.25 [mg CaCO₃/l] [mg CaCO₃/dm³] (ppm)
 - French degrees = 20.525 [°F] [°TH].
 - English degrees = 14.400 [°e] [grain CaCO₃/gal(UK)]
 - US = 11.990 [grain CaCO₃/gal(US)].
 - CaO = 115,000 [mg CaO/l] [mg CaO/dm³].
 - German degrees = 11,500 [°n] [°dH].

SECURING THE SCREWED CONNECTIONS OF THE WATER EXCHANGER

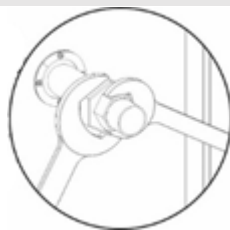

- ! When assembling the supply system for exchangers equipped with bolted connections, the exchanger connector must be relieved with an additional spanner.



**SUPPLY PRINCIPLE FOR WATER EXCHANGERS
OUTSIDE THE BASE SECTION OF THE CONTROL PANEL**

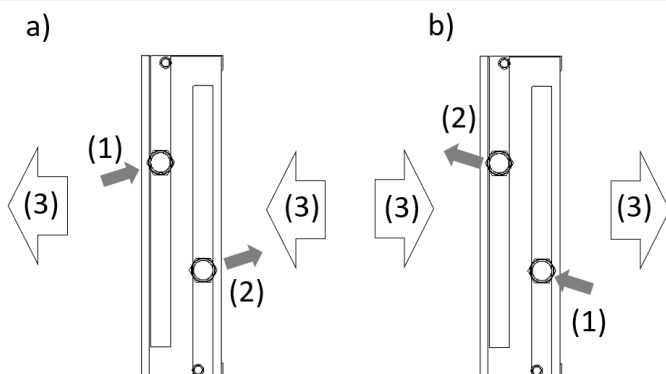

- a) Left-hand execution
- b) Right-hand execution
- (1) Heating/cooling medium supply to the exchanger
- (2) Return from the factor exchanger
- (3) Direction of air flow in the air handling unit

The exchanger's fluid supply and return connections should be configured so that the exchanger operates in countercurrent mode. The co-current mode of operation of the exchanger provides a lower average temperature difference, affecting its operating efficiency.

5.2 CONDENSATE DRAINAGE

Moisture can condense on the surfaces of the air coolers and heat recovery exchanger from the air. The condensed moisture (condensate) flows into the drip tray located below these functions. The installer must connect the drip trays to the drainage system, including the use of traps. Condensate drainage is led outside the air handling unit casing. The outlets are located in the condensate drip trays of the coolers (the diameter of the drain pipe is 32 mm).



- ! For the correct operation of the air handling unit, it is required to install traps for the baths on the suction side of the fan (on negative pressure).
- ! It is recommended to use siphons for baths located on the discharge side of the fan (on positive pressure).
- ! Ball valves cannot be used on the discharge side of the fan.
- ! It is not possible to combine different condensate drains into one trap.
- ! Fill the siphon with water before starting the air handling unit.
- ! If the environment is cold, insulate the drainage pipes.
- ! If the condensate is in danger of freezing, a suitable system for heating it must be used.

CONDENSATE DRAIN – U-TRAP CONNECTION

$p < p$ atmospheric

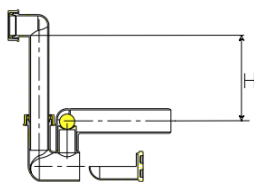

$p > p$ atmospheric

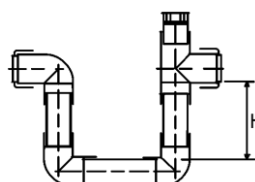

H [mm] = total fan discharge in mm H₂O

H [mm] = Dp [Pa] * 0.1

Dp [Pa] - fan discharge in pascals

6 ELECTRICAL CONNECTION

6.1 ELECTRICAL CONNECTION TO THE POWER BOX

VENTUS COMPACT HP units are pre-wired at the factory and are equipped with advanced control and safety Controls. The Controls system is based on built-in and integrated and integrated controllers: uPC3 and C.CPCO MINI, which ensures complete control and protection of the unit together with the heat pump system (system: OSSTDmCOMN).

No on-site configuration of the device is required.

JUNCTION BOX (CONTROLS SWITCHBOARD) IN THE CONTROL PANEL

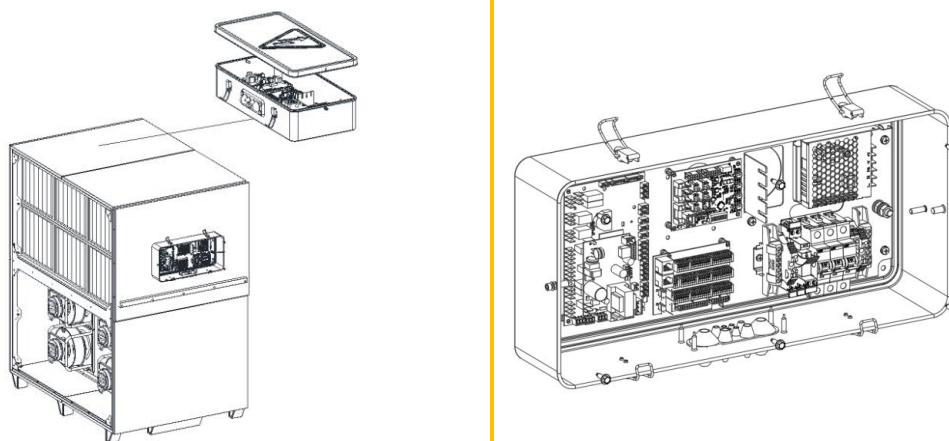

- ! The junction (control) box can optionally be mounted on the back of the unit. Mounting on the back of the panel is recommended for outdoor versions of the unit.
- ! The cross-sections and types of cable (e.g. shielded cable) supplying power to individual functional components should be selected based on the rated current and specific operating conditions (e.g. ambient temperature, wiring method, distance from power source).
- ! Electric heaters and water pumps for heaters installed in separate sections from the heat pump are to be supplied from an external switchboard (not supplied)

CONNECTING THE POWER SUPPLY 3~400V AC+N+PE 50Hz

Size AHU	Fan code	Max. number of fans up to 0.75kW per section	Built-in Heater electric	Rated current	Security	Power cable
[-]	[-]	[-]	[-]	[A]	[-]	[3~ 400V AC+N+P]
VVS021c	250 0.7kW 1.58x1	x1		37	C40/3	5x 10 mm ²
VVS021c	225 0.74kW 1.33x2	x2		37	C40/3	5x 10 mm ²
VVS021c	225 0.74kW 1.33x2	x2		37	C40/3	5x 10 mm ²
VVS021c	250 0.7kW 1.58x1	x1		37	C40/3	5x 10 mm ²
VVS021c	250 0.7kW 1.58x1	x1	4kW	41	C40/3	5x 10 mm ²
VVS021c	225 0.74kW 1.33x2	x2	4kW	41	C40/3	5x 10 mm ²
VVS021c	225 0.74kW 1.33x2	x2	4kW	41	C40/3	5x 10 mm ²
VVS021c	250 0.7kW 1.58x1	x1	4kW	41	C40/3	5x 10 mm ²
VVS030c	225 0.74kW 1.33x2	x2		37	C40/3	5x 10 mm ²
VVS030c	225 0.74kW 1.33x3	x3	6kW	39	C50/3	5x 10 mm ²
VVS030c	225 0.74kW 1.33x2	x2	6kW	44	C50/3	5x 10 mm ²
VVS030c	225 0.74kW 1.33x3	x3		39	C40/3	5x 10 mm ²
VVS030c	225 0.74kW 1.33x2	x2		37	C40/3	5x 10 mm ²
VVS030c	225 0.74kW 1.33x3	x3		39	C40/3	5x 10 mm ²
VVS030c	225 0.74kW 1.33x2	x2		37	C50/3	5x 10 mm ²
VVS030c	225 0.74kW 1.33x3	x3		47	C50/3	5x 10 mm ²
VVS040c	250 0.7kW 1.58x2	x2		42	C50/3	5x 10 mm ²
VVS040c	225 0.74kW 1.33x3	x3		44	C50/3	5x 10 mm ²
VVS040c	250 0.7kW 1.58x2	x2		42	C50/3	5x 10 mm ²
VVS040c	225 0.74kW 1.33x3	x3		44	C50/3	5x 10 mm ²
VVS055c	225 0.74kW 1.33x2	x2		42	C50/3	5x 10 mm ²
VVS055c	225 0.74kW 1.33x4	x4		48	C50/3	5x 10 mm ²
VVS055c	225 0.74kW 1.33x4	x4		48	C50/3	5x 10 mm ²
VVS055c	225 0.74kW 1.33x3	x3		44	C50/3	5x 10 mm ²
VVS055c	225 0.74kW 1.33x3	x3		44	C50/3	5x 10 mm ²
VVS055c	225 0.74kW 1.33x2	x2		42	C50/3	5x 10 mm ²
VVS075c	250 0.7kW 1.58x4	x4		44	C50/3	5x 10 mm ²
VVS075c	250 0.7kW 1.58x5	x5		48	C50/3	5x 10 mm ²
VVS075c	250 0.7kW 1.58x3	x3		40	C50/3	5x 10 mm ²
VVS075c	250 0.7kW 1.58x4	x4		44	C50/3	5x 10 mm ²
VVS075c	250 0.7kW 1.58x5	x5		48	C50/3	5x 10 mm ²
VVS075c	250 0.7kW 1.58x3	x3		40	C50/3	5x 10 mm ²

7 ELECTRIC HEATER

7.1 GENERAL INFORMATION

The electric heater can be an optional accessory (separate section) or built into the base block of the air handling unit (VVS021c, VVS030c). If the heater is built into the base block, the heater is connected at the factory to the main supply point of the air handling unit.

The method of connecting the optional heater is described in separate documentation, which is available via the link provided in the QR code on the plate. Detailed information can also be found in the document "Electric heaters - slices Technical and operating documentation" on the manufacturer's website www.vtsgroup.com.

The heater consists of heating elements (heaters), a connection terminal, control Controls (SCCR) and over-temperature protection.

The heaters are Cr-Ni-Fe heating wires of 6kW/400V. They are connected in heating slices (heating sections). The heater can consist of: 1, 2 or 3 heating slices.

Electric heaters can be supplied in two power variants - low power to suit AHUs with relatively low heating requirements and high wattage, covering AHU cases for facilities with higher heating requirements.

These types differ primarily in the types of electrical connection of the individual heaters in the heater unit (star connection for low power or delta connection for high power).

The appropriate connection of the heaters to each other is made at the heater manufacturing stage - the installer is only required to connect the power and control wires - no modifications to the heater system connections from the factory configuration are allowed.

DUCT INSULATION ELECTRIC HEATER - TO BE MADE ON SITE.



- ! Electric heaters are available in a ducted version (without thermal insulation and feet/frames) as well as a built-in version in the MW40 insulation casing.
- ! When insulating ventilation ducts, which must include the casing of the electric heater, it must be ensured that the connection point (especially its ventilation openings) is outside the insulation layer.

Modulating Supply Voltage Depending on Heating Power Demand (First Heating Slice).



The first slice is controlled steplessly 0-10V, each remaining slice (ON/OFF) ON-OFF.

Each time a regulated slice reaches full output, the demand is passed on to the next slice, which starts operating at full capacity. Any additional heating output will be realised by steplessly increasing the regulated heating output of the modulating slice.

DETAILS OF THE ELECTRICAL INSTALLATION

Type of network	TN
Rated supply voltage	3x400V AC
Rated insulation voltage	400V
Rated withstand surge voltage	2500V
Rated short-circuit current I _{cw} for individual circuits - effective value of the periodic component withstanding for 1s, i.e. the short-circuit current expected at the switching voltage	6kA
Rated short-circuit current	6kA
Simultaneity factor	0,8
Rated frequency	50 Hz
Degree of protection	IP00
Permissible operating temperature	0 °C ÷ (+50) °C
Supply voltage of control circuits	24V DC
Type of network	TN
Rated supply voltage	3~400V AC
Rated insulation voltage	400V
Rated withstand surge voltage	2500V

7.2 HEATER POWER CONNECTION AND CURRENT PROTECTION



- ! The power supply connection must be made using a separate switchboard, which is not supplied by VTS.
- ! The heater connection should be made in such a way that the heater cannot be switched on when the fan is not switched on - this is ensured by factory-fitted, series-connected safety devices in the form of a thermostat and pressure switch, which prevent the heater from being switched on if the temperature and air flow conditions are not met.
- ! If the fan stops, it is essential to switch off the power supply to the heater.

The type of conductors used for the various heater functions is shown in the table below. The conductor cross-section and its protection should be selected based on the information indicated in the table above.

Cable types for connecting electric heaters			
Application of the cable	Rated voltage	Type	Operating temperature
Power supply for electric heaters	3~400V AC	multi-stranded, stranded copper wire	(-30) C° ÷ (+60) C°
Power supply for the control system	1~230V AC	multi-stranded, stranded copper wire	(-30) C° ÷ (+60) C°
Control of the heater Controls system	24V DC	multi-stranded, stranded copper wire	(-30) C° ÷ (+60) C°

CONNECTION OF ELECTRIC HEATER WITH 1X18KW SWITCHBOARD

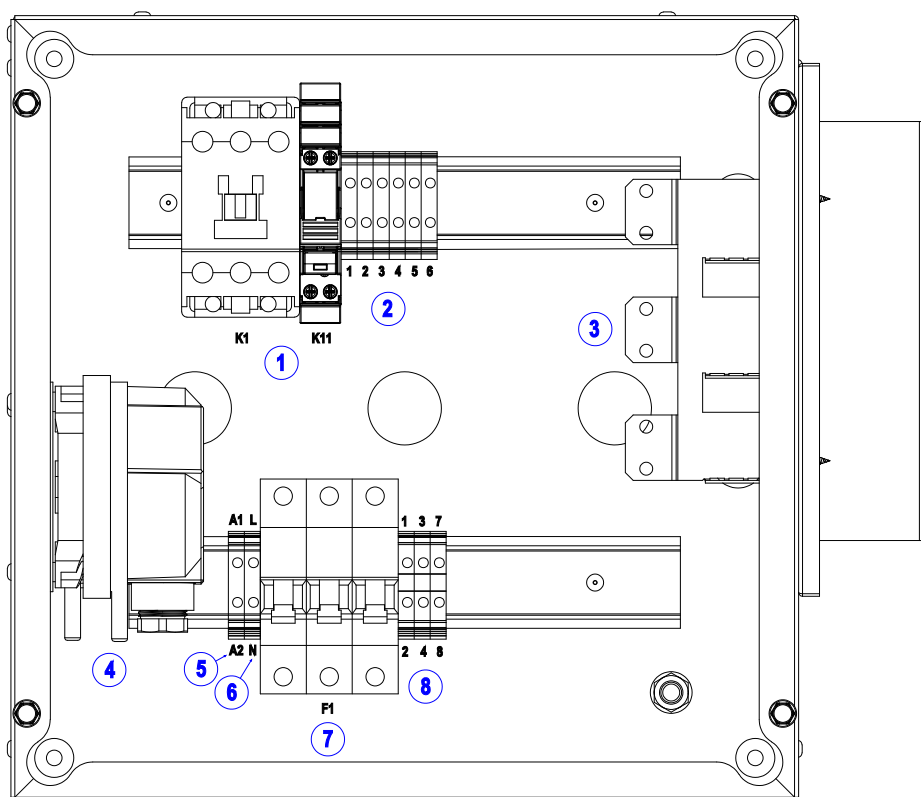

Designation	Description	Connection	Comments
1	relays / contactors	factory	-
2	heater terminals	factory	-
3	heaters	factory	-
4	pressure switch	factory / <u>installer</u>	<u>the connection of the pressure switch tubes is made by the user</u>
5	signal terminals - alarm	<u>on site / installer</u>	-
6	power terminals 1f	<u>on site / installer</u>	-
7	overcurrent circuit breakers	<u>on site / installer</u>	-
8	signal terminals - control	<u>on site / installer</u>	-

The switchgear views shown are intended to illustrate the arrangement of components inside the switchgear enclosure. Please note that they are for illustrative purposes only - when making electrical connections, always refer to the electrical diagrams.

CONNECTION OF ELECTRIC HEATER WITH 2X18KW SWITCHBOARD

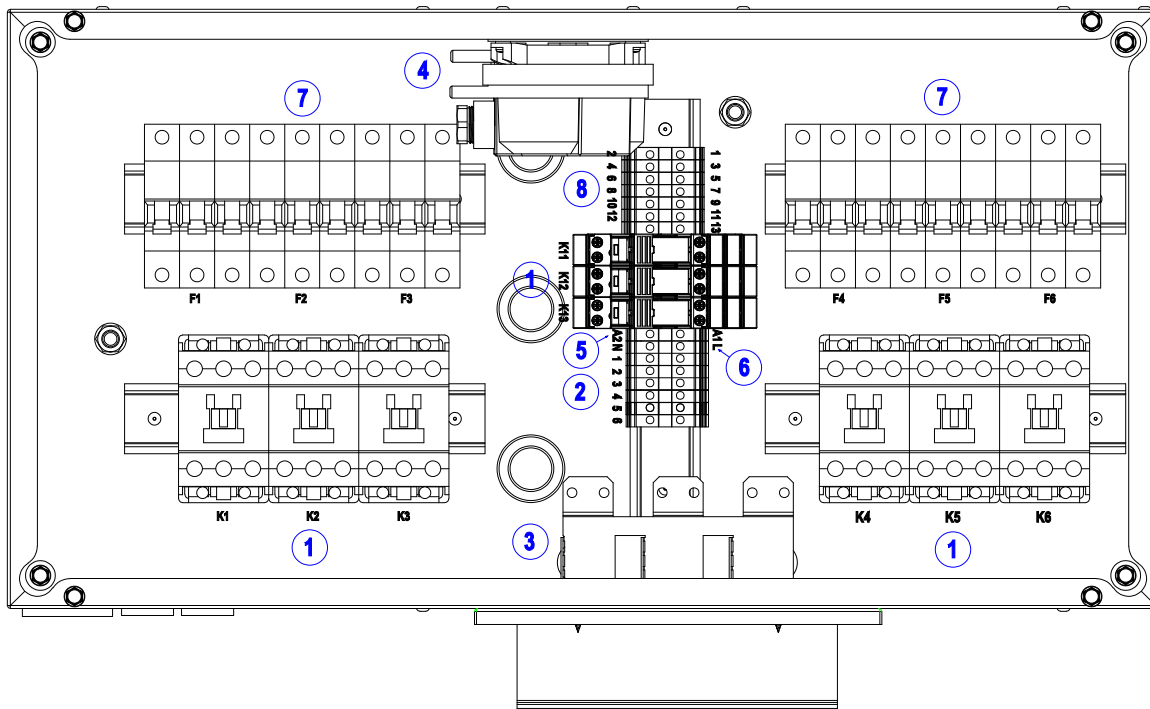

Designation	Description	Connection	Comments
1	relays / contactors	factory	-
2	heater terminals	factory	-
3	heaters	factory	-
4	pressure switch	factory / <u>installer</u>	<u>the connection of the pressure switch tubes is made by the user</u>
5	signal terminals - alarm	<u>on site / installer</u>	-
6	power terminals 1f	<u>on site / installer</u>	-
7	overcurrent circuit breakers	<u>on site / installer</u>	-
8	signal terminals - control	<u>on site / installer</u>	-

The switchgear views shown are intended to illustrate the arrangement of components inside the switchgear enclosure. Please note that they are for illustrative purposes only - when making electrical connections, always refer to the electrical diagrams.

CONNECTION OF ELECTRIC HEATER WITH 4X18KW SWITCHBOARD

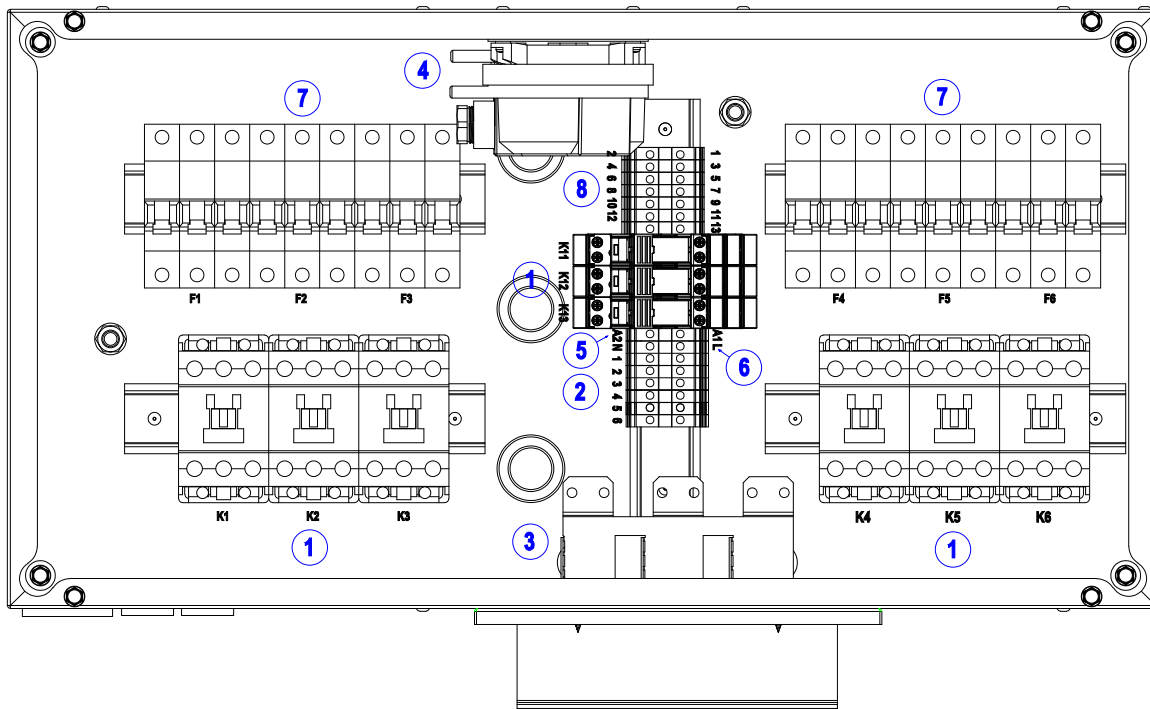

Designation	Description	Connection	Comments
1	relays / contactors	factory	-
2	heater terminals	factory	-
3	heaters	factory	-
4	pressure switch	factory / <u>installer</u>	<u>the connection of the pressure switch tubes is made by the user</u>
5	signal terminals - alarm	<u>on site / installer</u>	-
6	power terminals 1f	<u>on site / installer</u>	-
7	overcurrent circuit breakers	<u>on site / installer</u>	-
8	signal terminals - control	<u>on site / installer</u>	-

The switchgear views shown are intended to illustrate the arrangement of components inside the switchgear enclosure. Please note that they are for illustrative purposes only - when making electrical connections, always refer to the electrical diagrams.

7.3 THERMAL CUT-OFF (THERMIC)

The functionality of the thermostat is based on the properties of the bimetallic element - it causes the contacts of the heater control circuit to open when the air temperature near the thermostat is 65°C. After an emergency shutdown, the heater automatically switches on when the air temperature drops by 20°C. After a deliberate or emergency (due to overheating) power off, the supply fan must run for some time (0.5-5 min) so that the heaters reach normal temperature.



! The thermal switch is an integrated, factory-fitted component of each heater patch - no additional installation or electrical connection by the installer is required.

THERMAL CUT-OFF - CHARACTERISTICS

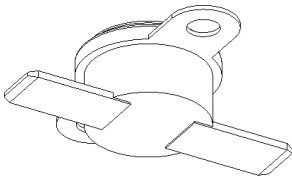
Thermal switch	Connection	Comments
	Function	heater overheating protection (temperature control of heating elements)
	Construction	<ul style="list-style-type: none"> metal casing two screw terminals bimetallic element with NC contact function
	Rated operating voltage	30V DC
	Output signal type	potential-free (changeover contact)
	Activation temperature	(+65) °C
	Temperature hysteresis	17 °C

7.4 DIFFERENTIAL PRESSURE SWITCH

The differential pressure switch is another safety element, in addition to the thermostat, which prevents the heater from operating under unallowable conditions. It prevents the heater from switching on if the pressure generated by the fan units on the supply side of the air handling unit is insufficient to ensure safe operation of the heating elements.



! The pressure switch is a factory fitted and electrically connected component - **the connection of the pressure switch pressure hoses must be made on site according to the following instructions:**

- one of the conductors should be routed to atmospheric pressure - if the switchboard is installed on a duct (outside), the cable does not need to be connected - there is atmospheric pressure in the switchboard,
- the second of the hoses should be connected at positive or negative pressure in the air handling unit or duct (before or after the supply motor),
- it is permissible to relocate the pressure switch outside the switchboard (in the duct version of the heater) in order to avoid the need to run long measuring tubes - the recommended position of the pressure switch is horizontal, in the vertical position the reading is 11Pa higher than the actual one.



! The switching threshold of the pressure switch is 20 Pa. When connected to the AHU, check that the pressure switch is operating correctly for the smallest available capacity of the air handling unit.

If no differential pressure is detected, change the connection point of the second pressure hose to the system.

! In the opposite case - **when for a given pressure switch setting the pressure difference is detected even if the unit is switched off** (allowing the heater to operate **even if** the fans are not running), the setting should be gradually increased until correct operation is obtained - it is indicated by the electric heater not operating despite the occurrence of control signals, if the pressure switch does not detect the pressure difference between the measurement channels - permission should be given only after the fans are started up.

! **Once the pressure switch is fully connected, the heater shutdown test must be performed.** To do so, force the electric heater control manually (e.g. by providing control signals for the heater from the controller) and at the same time stop controlling the fans. The pressure switch should prevent the electric heater from operating (this will be visible e.g. by disconnecting the contactors in the switchgear).

DIFFERENTIAL PRESSURE SWITCH - CHARACTERISTICS

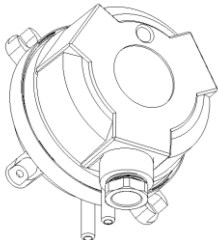
Differential pressure switch	Connection	Comments
	Function	protection of the heater against overheating (control of pressure difference between supply air and atmospheric pressure)
	Construction	<ul style="list-style-type: none"> plastic casing, two screw terminals, diaphragm connected to mechanical module
	Rated operating voltage	30 V DC
	Output signal type	potential-free (changeover contact)
	Measuring range	20-300 Pa

7.5 CONNECTION OF ELECTRIC HEATER CONTROL

MARKING OF THE ELECTRIC HEATER CONNECTION CABLE - PLUG&PLAY CONTROLS

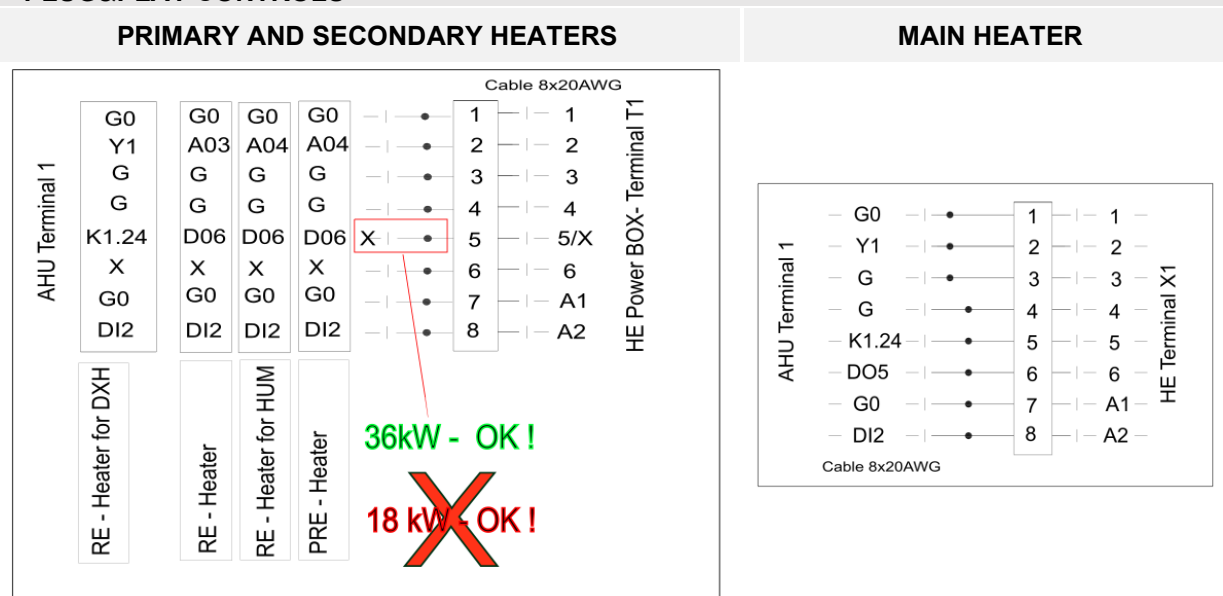

5/x - connect only up to 36kW

AHU Terminal 1 - Connection terminal "Terminal 1" in the panel box/distribution panel.

HE Power BOX - Connection terminal X1 in the electrical heater box/distribution panel.

RE-Heater - Secondary heater for a case other than the following.

RE-Heater DXH - Secondary heater for heat pump unit (C_dhx).

RE-Heater for HUM - Secondary heater for the humidifier unit.

PRE-Heater - Pre-heater.

K1.24 - the connection should be made to pin 24 of the pump relay (K1) located in the control panel of the AHU

CONNECTION OF ELECTRIC HEATER AUTOMATICS - CONTACTS: 1, 3, 4, L, N, A1, A2

Terminal No.	Terminal name	Signal name	Control Box	Connection terminal on the control box*			
1	GND	Grounding	⇒ CBX VTS	G0			
			Plug & Play	G0			
			Other than VTS	GND			
3	24V DC	Power supply 24V DC	⇒ CBX VTS	G			
			Plug & Play	G			
			Other than VTS	+24V DC			
4	St1	Grade 1	⇒	Number of sections			
				1	2	3	
				G	G	G	
				G	G	G	
			⇒	Other than VTS	+24V DC	+24V DC	+24V DC
L N	L N	Power supply 230V AC	⇒	230V AC			
A1	A1	Confirmation of work	⇒ CBX VTS	DI2*			
			Plug & Play	DI2"			
			Other than VTS	free voltage contact			
A2	A2	Confirmation of work	⇒ CBX VTS	G0			
			Plug & Play	G0			
			Other than VTS	free voltage contact			

If the system includes a water heater, only the frost protection is connected to DI2.

CONNECTION OF ELECTRIC HEATER AUTOMATICS - CONTACT 2

Terminal No.	Terminal name	Signal name	Control Box	Connection terminal on the control box*	Terminal No.	
2	0-10V	Signal 0-10V	⇒	CBX VTS	Main	Y1
					Preliminary	AO2
					Secondary - heat pump unit (C_dxh)	NO1
					Secondary - unit with humidifier	NO1
					Secondary - Other case	NO1
			⇒	Plug & Play	Main	Y1
					Preliminary	AO4
					Secondary - heat pump unit (C_dxh)	Y1
					Secondary - unit with humidifier	AO4
					Secondary - Other case	AO3
⇒	Other than VTS	All	0-10V DC			

CONNECTION OF ELECTRIC HEATER AUTOMATICS - CONTACT 5

Terminal No.	Terminal name	Signal name	Control Box	Connection terminal on the control box*	Terminal No.		
					Number of sections		
					1	2	3
5	St2	Degree 2	⇒ CBX VTS	Main	-	K1.24**	K1.24**
				Preheater	-	NO3	
				Reheater with DXH	-	K1.24**	
				Reheater with humidifying	-	NO3	
				Reheater - Other case	-	NO3	
			⇒ Plug & Play	Main	-	K1.24**	K1.24**
				Preheater	-	DO6	
				Reheater with DXH	-	K1.24**	
				Reheater with humidifying	-	DO6	
				Reheater - Other case	-	DO6	
			⇒ Other than VTS	All		+24V DC	+24V DC

** the connection should be made to pin 24 of the pump relay (K1) located in the AHU control panel

CONNECTION OF ELECTRIC HEATER AUTOMATICS - CONTACT 6

Terminal No.	Terminal name	Signal name	Control Box	Connection terminal on the control box*	Terminal No.
6	St3	Grade 3	⇒ CBX VTS	Main	NO6
				Preheater	
				Reheater with DXH	
				Reheater with humidifying	
				Reheater - Other case	
			⇒ Plug & Play	Main	DO5
				Preheater	
				Reheater with DXH	
				Reheater with humidifying	
				Reheater - Other case	
			⇒ Other than VTS	All	+24V DC

8 PLUG&PLAY CONTROLS COMPONENTS

The *VENTUS COMPACT TOP* base unit including hexagonal exchanger, fans and air filters and optional water heater is supplied as a pre-wired unit with the configured Controls system connected.

The Controls system is based on the factory-programmed and built-in uPC3 controller.

Peripheral Controls components whose specifics require installation outside the base unit (room or duct mounted sensors, actuators, valves) are supplied in separate packages. It is necessary to connect them on site according to the installation and connection instructions.

LABELLING OF PLUG&PLAY CONTROLS COMPONENTS

Controls components requiring connection on site are equipped with connection cables that include a label with the method of connection to Terminal 1.

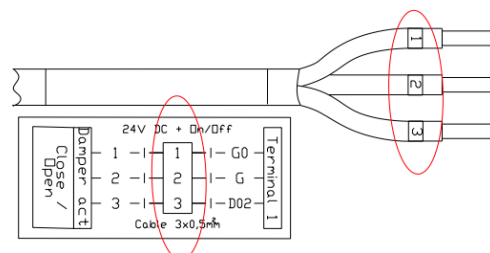

CONNECTIONS

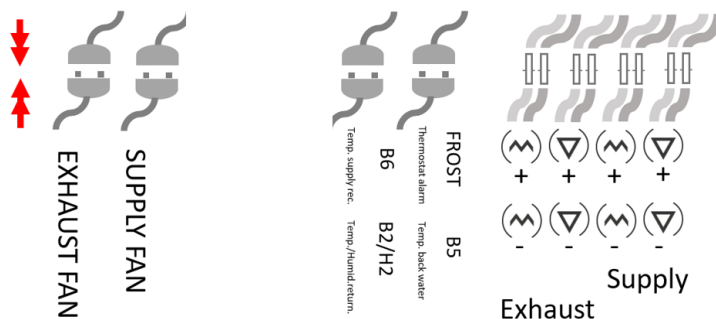

The basic configuration of the *VENTUS COMPACT* with heat recovery and heat pump is supplied as a pre-wired unit with a connected and configured control system.

„+” positive pressure side (red wire), „-” negative pressure side (blue wire),

8.1 STANDARD EQUIPMENT WITH FACTORY-FITTED CONTROLS ELEMENTS

STANDARD CONTROLS COMPONENTS - ASSEMBLY AND CONNECTION AT THE FACTORY		
Designation	Name	Location
	uPC3 controller	Controls switchgear
	Terminal 1 (T1)	Connection terminal for peripheral Controls components
	Security	Controls switchgear (according to the diagram)
B2	Temperature sensor	Return air from the room (extract before recovery)
H2	Moisture sensor	Return air from the room (extract before recovery)
B4	Temperature sensor	Exhaust air (exhaust after recovery)
B6	Temperature sensor	Supply air (for recovery)
B3	Temperature sensor	Outside air (before recovery)
	Differential pressure sensor	Supply air (pre-filter)
	Differential pressure sensor	Supply air (fan)
	Differential pressure sensor	Exhaust air (pre-filter)
	Differential pressure sensor	Exhaust air (fan)

The sensors are mounted in the heat recovery section.

8.3 CABLE STANDARDS

APPLICATION	TYPE WIRED	WIRING [mm]
Fire alarm relay	[2]	2x0,75
Multifunction switch	[2]	2x0,75
Optional multifunction switch	[2]	2x0,75
Supply air temperature sensor	[1]	2x0,75
Room/extract air temperature sensor	[1]	2x0,75
Return water temperature sensor for water heater	[1]	2x0,75
Electric heater (HE) alarm relay	[2]	2x0,75
Air-side antifreeze thermostat to protect the water heater from freezing	[2]	2x0,75
Analogue controlled water heater valve	[1]	3x0,75
Electric heater power control input	[1]	3x0,75
Water heater circulation pump contactor		3x1,5
Alarm relay for refrigerator/cooling unit/heating pump	[2]	2x0,75
Refrigerator start-up input	[2]	2x0,75
Chiller start-up input - stage I	[2]	2x0,75
Chiller start-up input - stage II	[2]	2x0,75
Recirculation throttle actuator	[1]	3x0,75
Bypass actuator for the cross-flow exchanger	[1]	3x0,75
HMI Basic UPC control panel - interface with limited functionality	[3]	UTP 1x2
HMI Advanced UPC control panel - full-function interface	[4]	8x0,1

ID	TYPE WIRED	DESCRIPTION
[1]	Cables for the transmission of control signals - screened copper wires. PVC insulation.	Rated voltage 300/500 V. Ambient temperature: 30 °C to 80 °C.
[2]	Copper conductors PVC insulation	Rated voltage 450/750V. Ambient temperature: -40 to 70 °C
[3]	Copper conductors PVC insulation	Rated voltage 150 V. Ambient temperature: - 20...60°C
[4]	Unshielded flat data cables.	Rated voltage 150 V. Ambient temperature: - 20...60°C

8.4 ANALOGUE INPUTS (NTC10K)

ANALOGUE INPUTS (NTC10K)

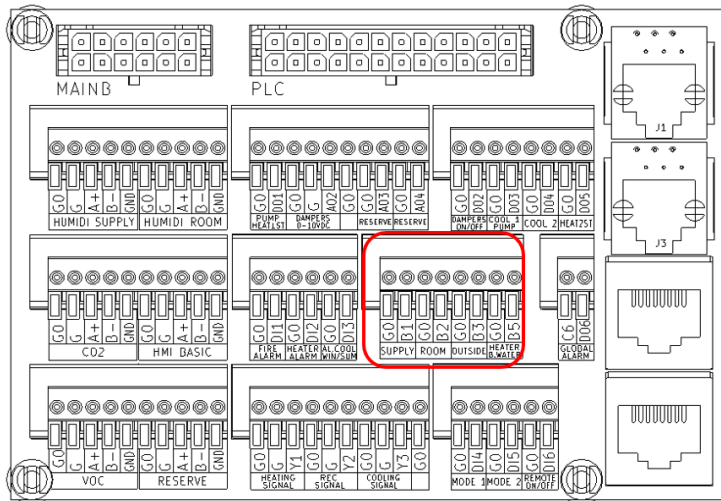

- B1 Duct temperature sensor - supply air
- B2* Temperature sensor - exhaust air
- B2/6 Duct sensor behind the pre-heater
- B3** Temperature sensor - outside air
- B5*** Touchscreen water heater temperature sensor.

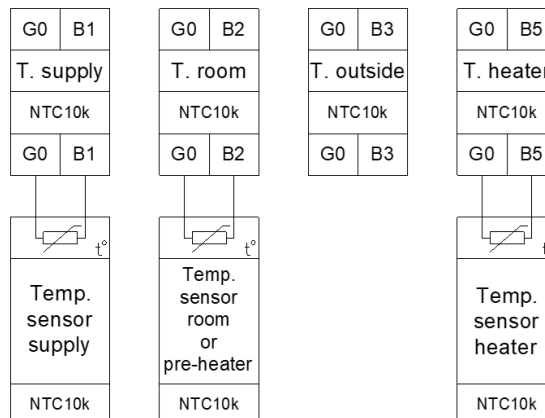

- **B2*** - Exhaust air temperature sensor which is factory fitted at the heat recovery. If a room sensor is used as the lead sensor (other than HMI BASIC), this sensor must be connected to B2 on terminal 1 T1
- **B3**** - Factory connections are made outside the T1 terminal directly at the uPC3 controller
- **B5***** - Touch sensor for water heater temperature which is assigned to one heater only (pre- or main heater). Priority of use is given to the pre-heater.

8.4.1 SUPPLY AIR TEMPERATURE SENSOR B1

SUPPLY AIR TEMPERATURE SENSOR B1

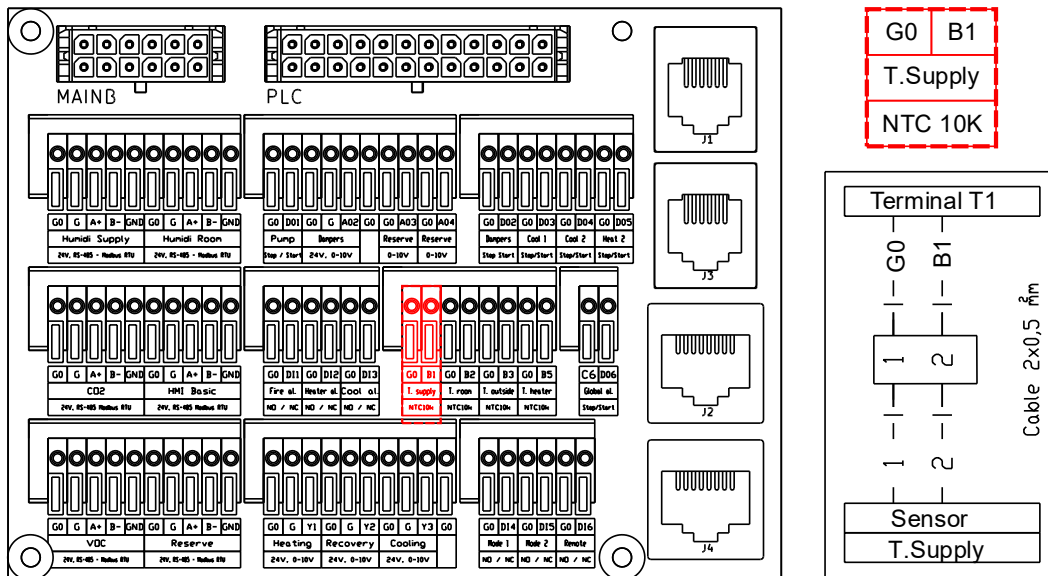

The sensor should be placed in the supply air duct behind the last section of the air handling unit, in a place representative of the temperature measurement (in a homogeneous air stream with a uniform temperature distribution).

The minimum distance between the air outlet of the unit section and the sensor should be no less than the distance defined as $1.5 \times$ the diagonal of the rectangular connection.

8.4.2 TOUCHSCREEN WATER HEATER TEMPERATURE SENSOR B5

TOUCHSCREEN WATER HEATER TEMPERATURE SENSOR B5

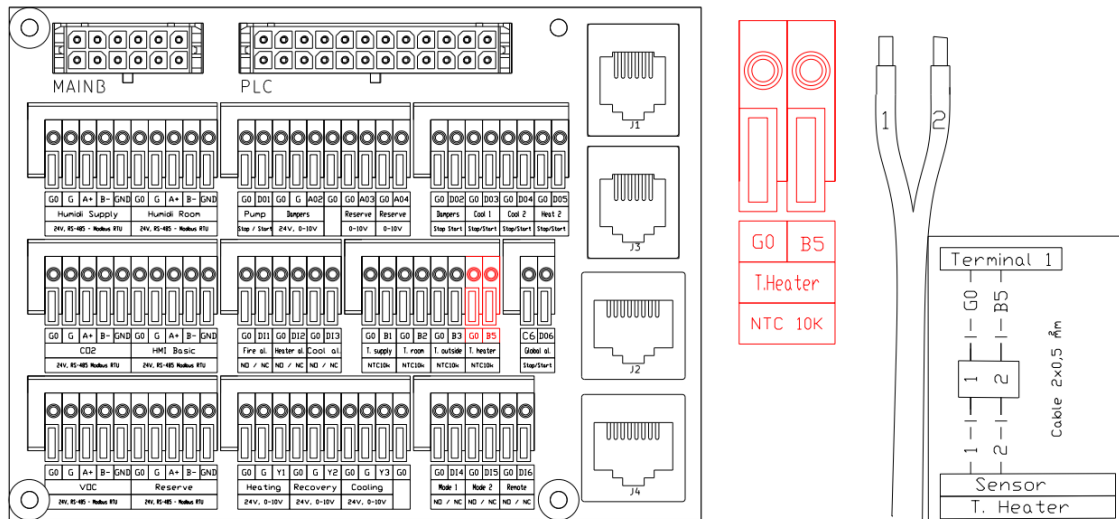

8.5 DIGITAL INPUTS

DIGITAL INPUTS

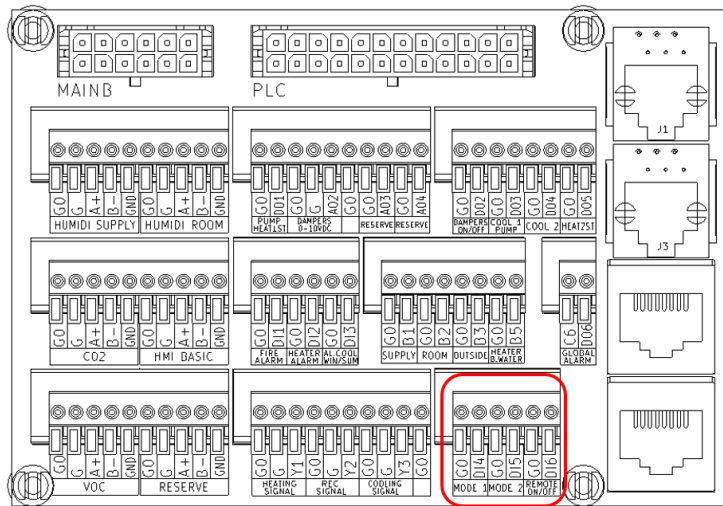

D11	Fire alarm
D12*	Heater alarm (freezing)
	Radiator alarm
D13	Humidifier alarm
D14	Cold source alarm
D15	Programmable external input (enabling the panel or overriding the selected operating mode)
Remote	

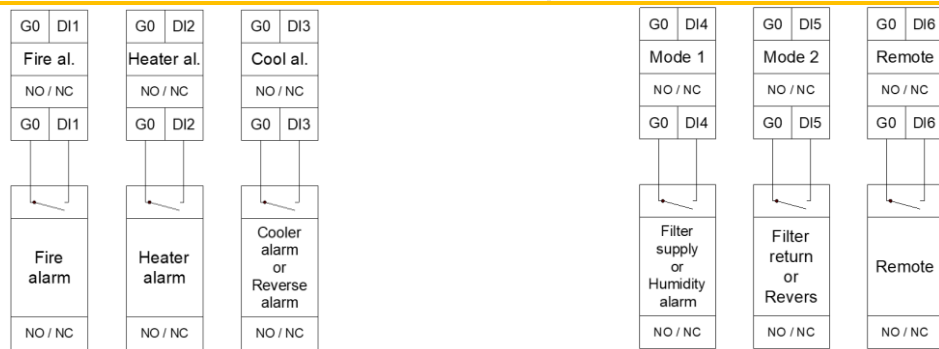

DI2* - Heater alarm (freezing). If there is no water heater and an electric heater is present, the alarm signal is used for the electric heater operation confirmation signal (A1/A2).

8.5.1 FIRE ALARM SIGNAL DI1

FIRE ALARM SIGNAL DI1

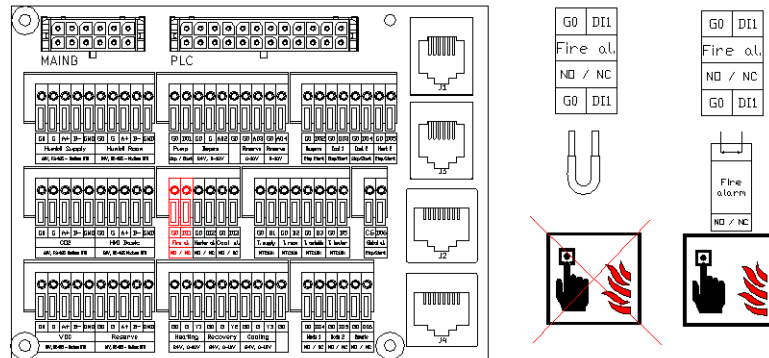

8.5.2 WATER HEATER FREEZE SENSOR DI2

WATER HEATER FREEZE SENSOR DI2

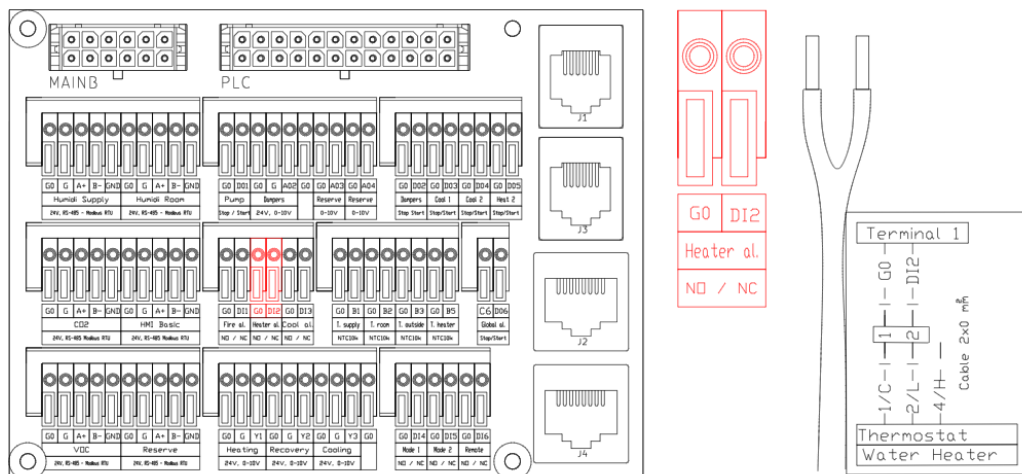

8.5.3 COLD SOURCE ALARM DI3

COLD SOURCE ALARM

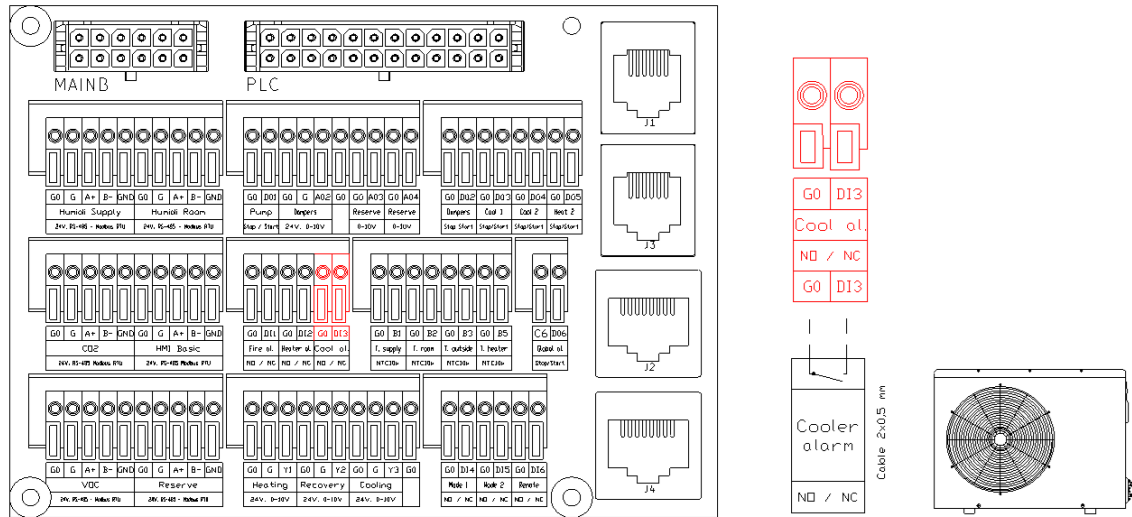

8.6 ANALOGUE OUTPUTS (0-10V DC)

ANALOGUE OUTPUTS (NTC10K)

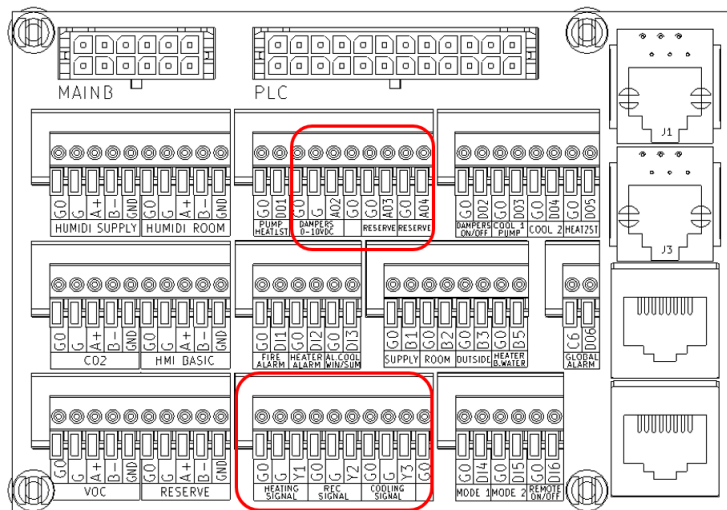

AO1*	Heat recovery
AO2	Air mixing
AO3	Humidification or secondary heater
AO4	Pre- or post-heater
Y1**	Main heater or secondary heater behind DX-H or mixing chamber
Y3***	Aftercooler or after-heater after DX-H or mixing chamber

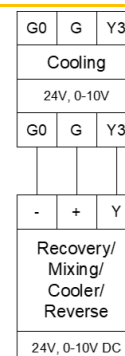
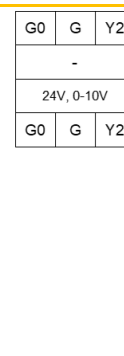
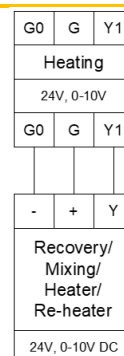
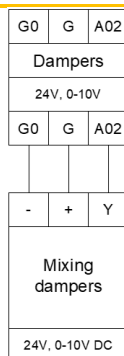

- **A01*** - factory connection outside terminal 1 (T1)
- **Y1**** - Priority: 1. main heater, 2. secondary heater for heat pump (DX-H), 3. Mixing chamber,
- **Y3***** Priority: 1. Refrigerator, 2. Heat pump secondary heater (DX-H), 3. Mixing chamber,

8.6.1 VALVE ACTUATOR OF THE WATER MAIN HEATER AND CONTROL SIGNAL OF THE ELECTRIC MAIN HEATER Y1

MAIN WATER HEATER Y1

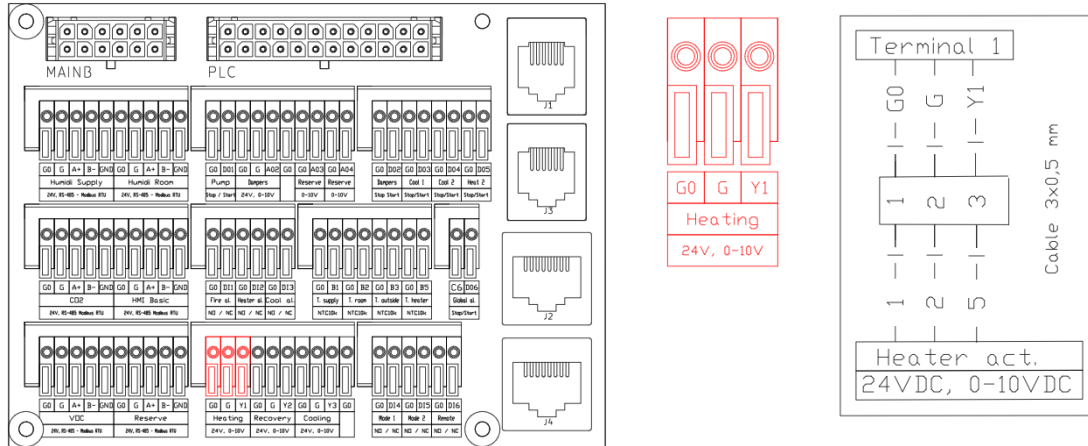

For the water heater, the control is connected to the valve actuator

8.6.2 VALVE ACTUATOR FOR WATER PRE- OR POST-HEATER AFTER DX-H Y1

WATER PRE- OR RE-HEATER BEHIND THE DX-H Y1

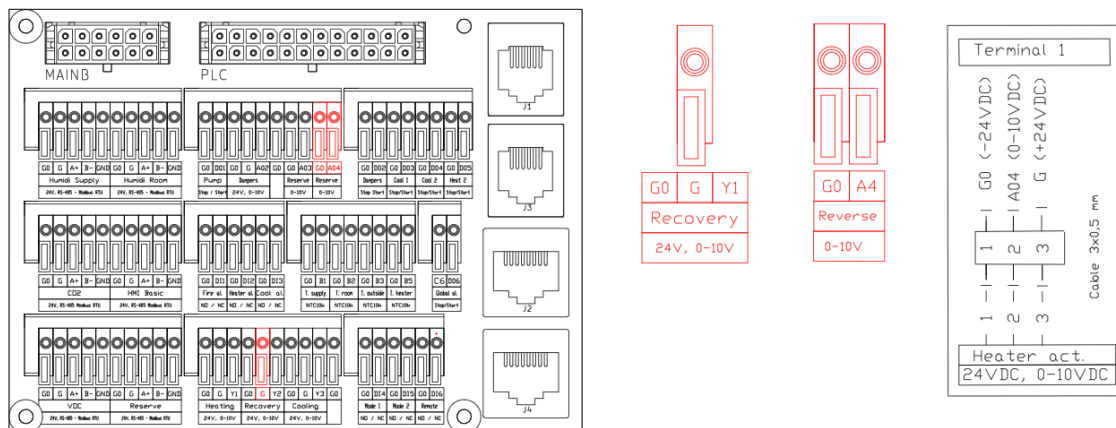

For the water heater, the control is connected to the valve actuator

8.7 DIGITAL OUTPUTS (24V DC)

DIGITAL OUTPUTS (24V DC)

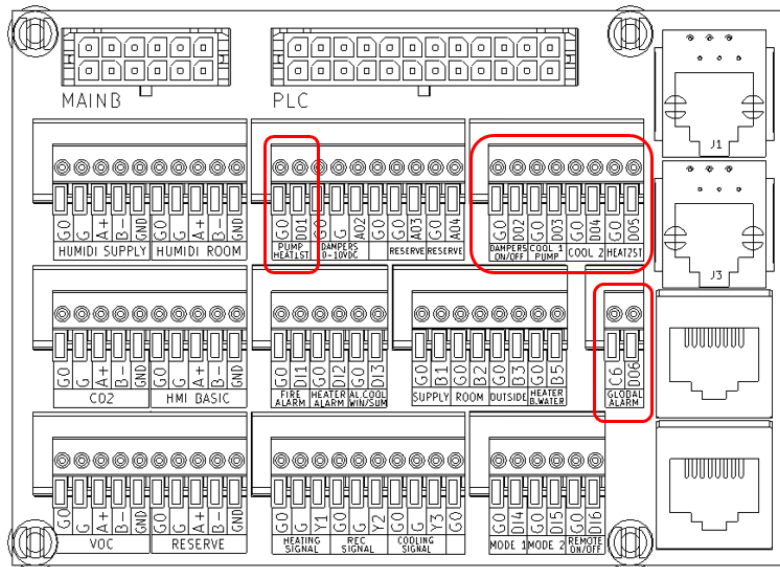

- D01 Main heater (or secondary heater if DX-H)
- D02 Air inlet and outlet passes
- D03 Radiator stage 1 or DX-H signal
- D04 Stage 2 cooler or stage 1 DX-H or humidifier or glycol recovery or redundant dampers
- D04 Heater stage 2 or DX-H stage 2
- D04 Pre-heater or secondary heater or general alarm
- D06

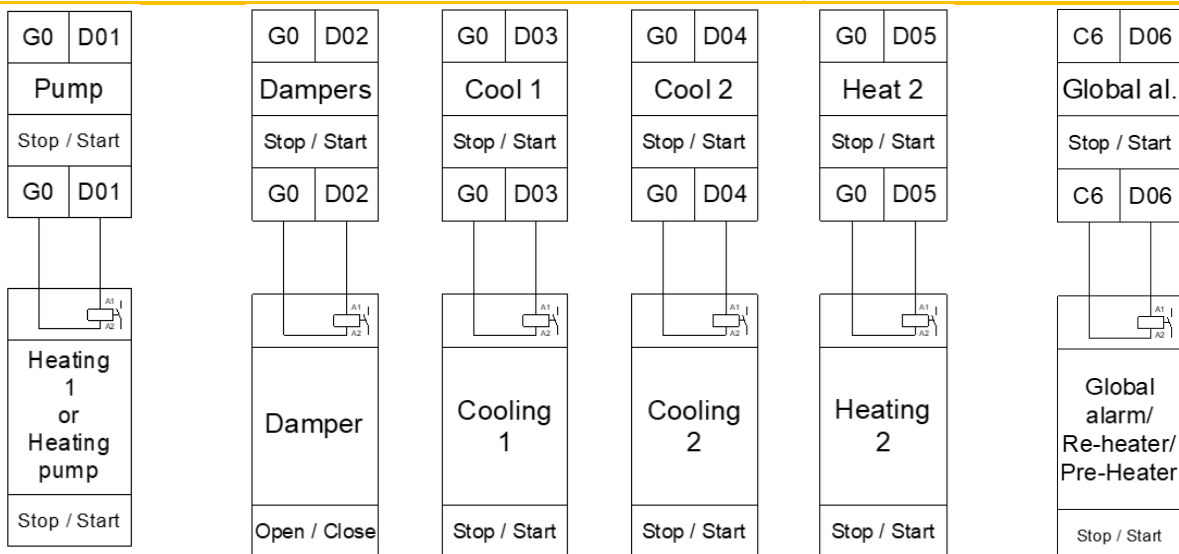

If 230V AC or potential-free contacts are required for the output signals, an isolating relay with a coil supplied at 24V DC from the controller's relay outputs must be used. The relay is not supplied with the unit.

8.9 CONNECTION OF THREE-WAY VALVES

HEATER VALVE CONNECTION

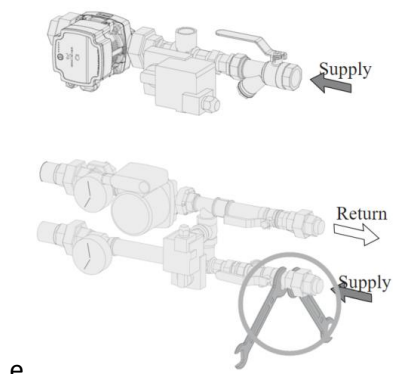
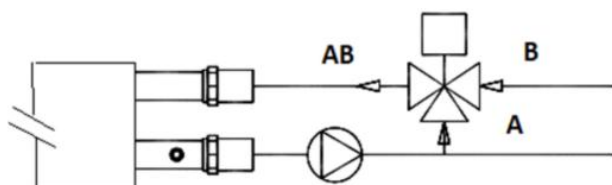

e

RADIATOR VALVE CONNECTION

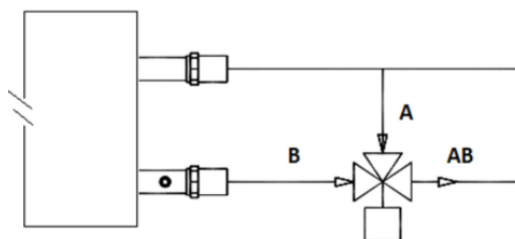

8.10 GSM COMMUNICATION

The device is equipped with automatic remote identification, configuration and data exchange mechanisms with external manufacturer systems as standard. A GSM gateway is installed inside the device. The GSM gateway is equipped with a SIM card if the device installation has been declared in EU countries.

!

- ! The GSM gateway is connected by default (RJ45) to the address 92.168.1.111/24
- ! After entering the address: 192.168.1.111 or 192.168.1.111:80, the visualization from the Carel controller is displayed (just like after connecting to the controller).
- ! After entering the address 192.168.1.111:8080 (http) or 192.168.1.111:8443 (https), the service interface appears (by default Login: admin, Password: admin).
- ! In the gateway interface, you can:
 - change the network parameters of the port through which you connect (the user is only interested in the port on the housing, the gateway is responsible for forwarding the connection to the controller),
 - connect to WIFI,
 - change the access password to the interface,
 - change the PIN code for the SIM card.

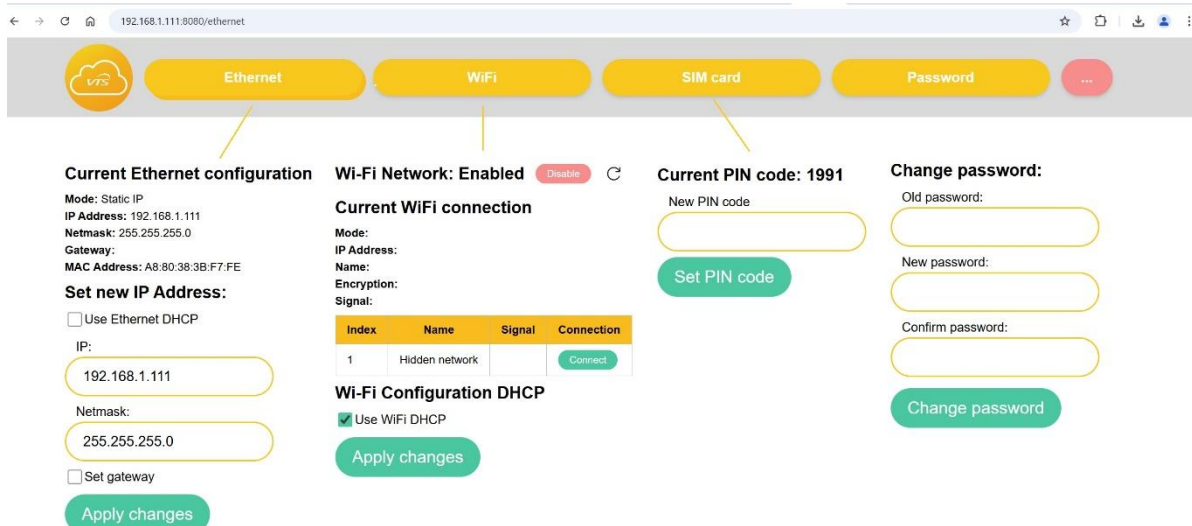

8.11 MODBUS RTU RS485 COMMUNICATION

MODBUS RTU RS485 COMMUNICATION

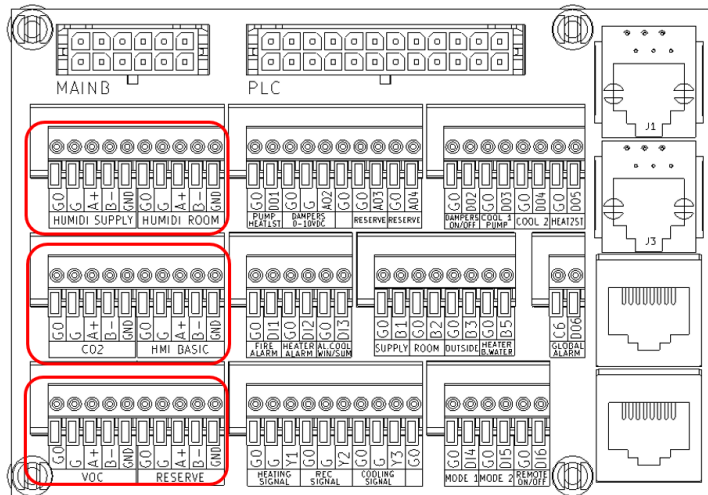

Humidity sensor - air supply

Humidity sensor - room (extract air)*

HMI Basic

CO2 sensor

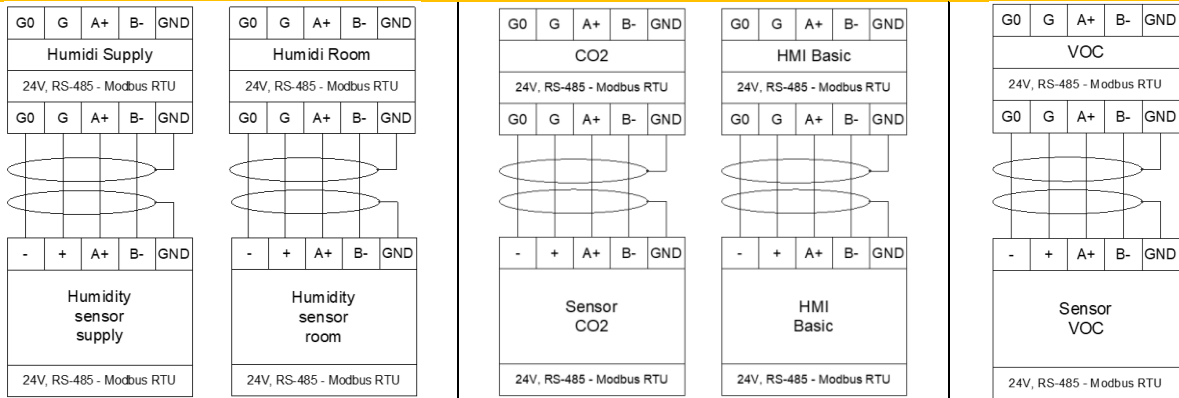

- Factory assembly

8.12 CONNECTION OF OPERATOR PANELS

8.12.1 HMI ADVANCED

HMI ADVANCED

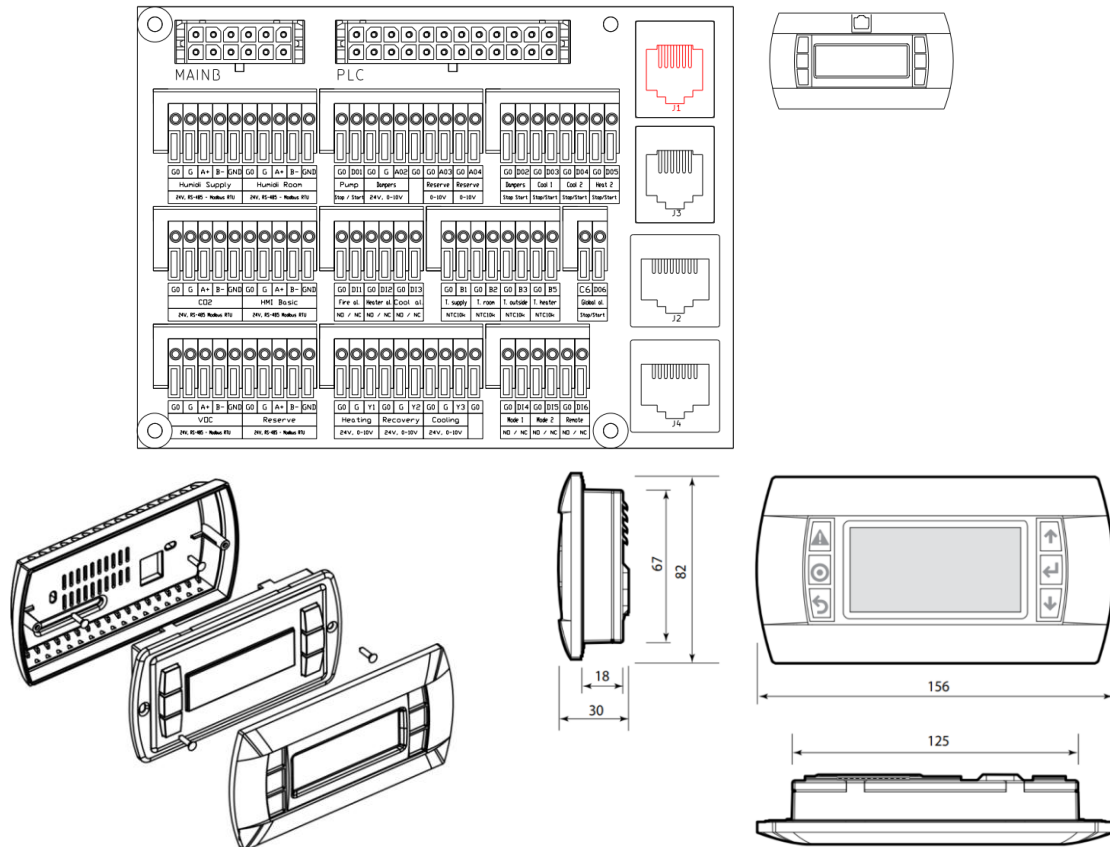

8.12.3 WebHMI and VMS

VENTUS MANAGEMENT SYSTEM



VMS - Ventus Management System - visualisation of panel operation with WebHMI function

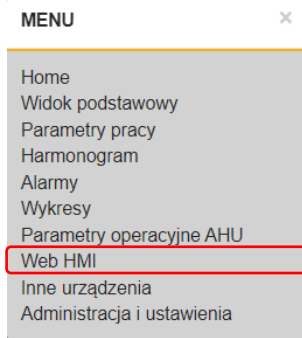

<http://192.168.1.111>



service



service

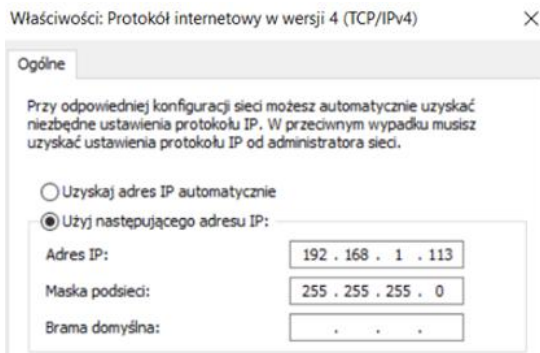

A fixed address is required to connect the controller IP: **192.168.1.xxx**, where xxx is different from 111. Subnet mask **255.255.255.0**

8.12.4 mHMI APPLICATION - BLUETOOTH DEVICE PAIRING

See chapter "BLUETOOTH MODULE AND mHMI APPLICATION".

9 FIRST START-UP

9.1 PREPARATION FOR THE FIRST START UP



- ! Before proceeding with the activities leading to the first start-up, read the operating instructions for the operator panels.
- ! The air handling unit may only be operated with the filters installed.
- ! Replace the air filters with clean ones after the first few hours of operation.
- ! In this manual, the mask graphics of the HMI ADVANCED operator panel are used. The masks in other panels may differ slightly from those shown in the manual.

9.1.1 CHECKING THE CONDITION OF THE INSTALLATION

PRE-START UP ACTIVITIES

Correct application of the device	As part of the commissioning procedure, it must be checked that the air conditioning/ventilating/heating unit in question has been constructed and installed in accordance with the structural/installation design and the manufacturer's guidelines.
Completeness of installation	Verify the presence of all AHU features and accessories (filters, dampers, actuators, valves, heaters/coolers, etc.) against the technical sheet - a full list of AHU components can be found in the technical sheet of the AHU, as well as on the labels of the individual delivery packages.
Connection to air ducts	Check that all ventilation equipment and components have been mechanically fitted and connected to the duct system.
Condition of air ducts	Check that the ducts are clean and the controls on the ducts are pre-adjusted.
Quality of installation on site	Check that the functional systems and components of the equipment have not been damaged during assembly or other operations, as well as Controls components,
Connection of external sources of cooling and process heat	Check that the hydraulic systems and the freon installation are complete and ready and ready for operation and that the correct amount of heating or cooling medium has been introduced to start up the unit.

OPERATIONS BEFORE STARTING UP (cont'd)

Grounding system	Check that earthing cables are in place, connecting the control systems to the ventilation ducts.
------------------	---

<p>Condensate system</p>	<p>Check that the condensate traps and drainage systems from the condensate gutter are fitted.</p>
<p>Controls peripherals</p>	<p>Check the connections of the peripheral devices (T1 terminal) - as the optional equipment of the control panel, such as operator panels and some temperature sensors, may differ depending on the chosen configuration, check that their connection is made through a dedicated T1 terminal, has been made in accordance with the documentation (pay particular attention to the correct connection of the 24V power supply and Modbus communication cables, (pay particular attention to the correct connection of the 24V power supply and Modbus communication cables, as their confusion may damage the entire communication bus of the control unit)</p>
<p>Electrical supply to the unit.</p>	<p>Check that the power supply is correctly connected to the main switch - the correct voltage must be applied to the block switchboard in accordance with the unit's wiring diagram in the relevant section of its technical data sheet or User's Manual (DTR).</p>
<p>Electric heater</p>	<p>Check that the power supply to the electric heater (if any) is correctly connected - the appropriate voltage must be applied to the heater switchboard in accordance with the wiring diagram of the appliance in the relevant section of its technical data sheet or the User's Manual (DTR).</p> <p>During operation of the air handling unit (and also prior to its initial start-up), when the heater is not operating, dust may settle on the heating elements. When the heater is switched on again, the heavy soiling can cause a smell of burning dust or even a fire hazard.</p> <p>Check the condition of the electrical connections, the condition of the heating elements and the degree of dirt on a regular basis (annually), especially before the first start-up and before the start of the heating period. Remove any dirt with a Hoover with a soft nozzle or compressed air.</p> <p>The operation of the overheating protection and the no-airflow protection should also be checked regularly. The air velocity in the AHU during heater operation should not be less than 1.5 m/s.</p>
<p>Closure of inspection panels.</p>	<p>Check that the inspection panels are closed - the rotating parts of the control panel can pose a risk to health and life when the protective covers are removed</p>

9.1.2 POWER CONFIGURATION OF OPTIONAL ELECTRIC HEATERS



! If the unit is equipped with an electric heater, the heater's heating sections must be configured.

CONFIGURATION OF ELECTRIC HEATER POWER STAGES

Read the power distribution from the diagram or technical data sheet. For example, we have:

0-10V DC = 25%, ST2 = 25%, ST3 = 50%

This notation means that the step-adjustable part of a given heater is 25% of its power (0-10V DC). The second step - step-connected (ST2) is also 25%, while the third step-connected (ST3) is 50% of the total power of the heater.

These parameters should be reflected in the appropriate settings of the uPC3 controller. The settings are made on the HMI Advanced screens:

- A05 for the pre-heater,
- A09 for the main heater,
- A06 for the secondary heater,

In the event that in a given system does not have one or both of the stages with step connection (ST2 / ST3 are not indicated in the diagram), the value 0% should be selected in the controller settings.

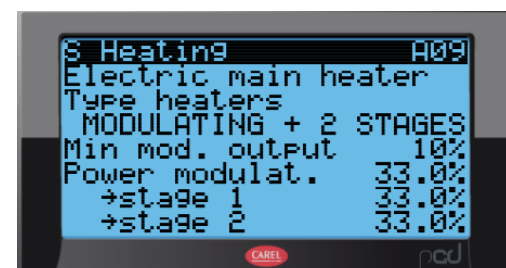

9.2 FIRST START-UP

9.2.1 FACTORY PARAMETERS

!

! The control unit, which is supplied as a Plug&Play standard, has its Controls configured according to the parameters and criteria specified in the unit's selection sheet.

!

No additional configurations on site are required to commission the control unit in Plug&Play standard in factory parameter mode (See "Preparing for initial commissioning").

! VTS automatics has a wide range of parameters for adjusting the device's operation to the specifics of the facility's installation. In order to improve the comfort of use, it is recommended that such adjustment be carried out.

! For basic commissioning of the control panel, it is sufficient:

- connect peripheral functions and peripheral Controls elements depending on the depending on the retrofit options provided,
- connect the fan sections (connectors located on the fan diaphragm for pressure measurement, control signal and power supply of the units),
- connect the pneumatic differential pressure measurement lines of the air filters,
- check the correctness of the connections made on the site,
- check the correctness of the sensor readings and the functioning of the elements mounted on the site.

!

BASIC FACTORY CONFIGURATION

Configuration of the application code including:

- type and mode of heat recovery operation,
- the type and parameters of the main heater,
- the type and parameters of the pre-heater,
- the type and parameters of the secondary heater,
- the type and parameters of the reversible system,
- mixing chamber parameters,
- humidifier operating parameters (air humidity control),
- occurrence of HMI Basic, HMI Basic2,

Configuration and settings:

- leading sensor,
- type of temperature control,
- type of humidity control,
- type of supply fan control (CAV/ VAV),
- type of extractor fan control (CAV/ VAV),
- type of supply fan motor controller (EC),
- type of extractor fan motor controller (EC),
- PID controllers for fans and other functions in the application,
- number of supply fans
- number of exhaust fans
- supply impeller size,
- Exhaust impeller size,
- discharge capacity,
- exhaust performance,
- discharge pressure,
- the discharge pressure,
- maximum speed for the supply fan motor,
- maximum speed for the exhaust fan motor,
- activation of the water heater touch sensor,
- Activation of the humidity transmitter
- Activation of the CO2 transducer (VOC sensor),

BASIC FACTORY CONFIGURATION - OPERATING PROFILES (MODE)						
PARAMETER			WORK PROFILES			
			Comfort** Comfort**	Optimum Low	Economic Ekono	StandBy StandBy
Temperature	T	°C	22	22	22	22
Relative humidity - RH	RH*	%	50	50	50	50
Air quality - CO2 content	ppm	ppm	600	600	900	900
Supply capacity	V * _S	% m ³ /h	100	X	X	X
Exhaust capacity	V * _E	% m ³ /h	100	X	X	X

- Work profiles: Comfort, Optimum, Economic require the time and date of their validity to be set in the calendar.
- Standby operating profile - requires parameter setting:
 - StandBy time, i.e. the minimum time for which the AHU is awakened in StandBy mode,
 - Wake-up time, i.e. the time determining the interval between automatic wake-ups of the AHU in standby mode.
- * - humidity control requires the unit to be equipped with humidification and dehumidification functions, otherwise the values are read-only,
- ** - 100% means the performance from the selection sheet.
- X – control is user configurable. The minimum air flow must be observed.

AHU	MINIMUM AIR FLOW
	[m ³ /h]
VVS021c	1470
VVS030c	1470
VVS040c	2800
VVS055c	2800
VVS075c	5250

9.2.2 START UP

PLUG&PLAY CONTROL PANEL COMMISSIONING

Switch on the power supply to the control panel

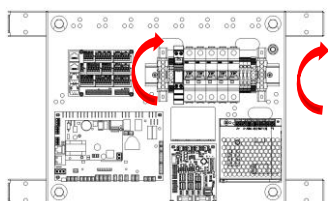

Enable HMI Advanced*

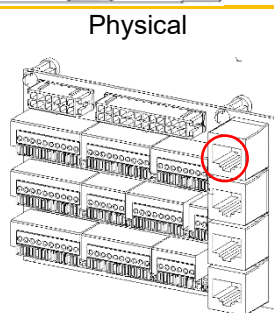

Physical

Virtual

<http://192.168.1.111>

Switch to OFF mode to any other mode (work profile) as preferred*

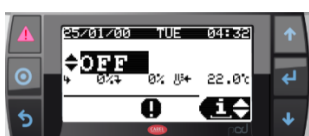

	Change in device status (operating mode)
OFF	Panel operation switched off (voltage reaching the panel)
ON	ECO One of the user configuration profiles
	OPTI One of the user configuration profiles
	COMF One of the user configuration profiles
StBy	Standby state of the unit. In the StBy state, the set room temperature is maintained. The fans are periodically activated to maintain the required air temperature. This mode is best at night when there is low or no thermal occupancy in the building.
AUTO	Schedule and calendar operation



- ! The start-up of the air handling unit is absolutely blocked by a fire alarm, the tripping of the thermal fan motor protection, the triple tripping of the electric heater protection and the triple tripping of the anti-freeze thermostat. Each of these events requires the cause of the alarm to be removed and then cleared.
- ! The correct operation of the power supply and the proper functioning of the BIOS is indicated by the yellow and green LEDs on the control PCB. The circuit is ready for operation half a minute after the power is switched on.
- ! - * Changing from OFF to another operating mode is also available from HMI Basic 2

9.2.3 HMI ADVANCED

HMI ADVANCED - NAVIGATION

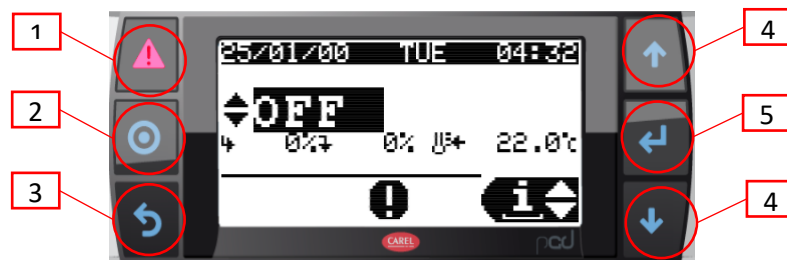

Simulation of equal pressures in the WEB HMI

1 "Alarm" button (calling up active and archived alarms, clearing alarms). When an alarm is active, the button is illuminated in red.

2 Button for changing the operating modes (OFF/Auto/Low/Econo/Comfort). Confirmation by pressing ENTER.

3 ESC button (return to previous field or screen)

4 Arrows to navigate up and down and to change parameter values

UP:

- Moving up through the menu screens (when the cursor remains in the top left corner)
- Increasing the parameter value

DOWN:

- Moving down through the menu screens (when the cursor remains in the top left corner)
- Decreasing the parameter value

5 ENTER button.

- selection of the parameter to be changed,
- to a different parameter,
- validation of the selected value



! The parameters available in the LCD display window depend on the type of air handling unit and the application of the Controls system. Therefore, in the case of AHUs without a heater, you will not see the options related to the heating section.

! The HMI Advanced cannot be used as a room temperature sensor.

HMI ADVANCED NAVIGATION cont.

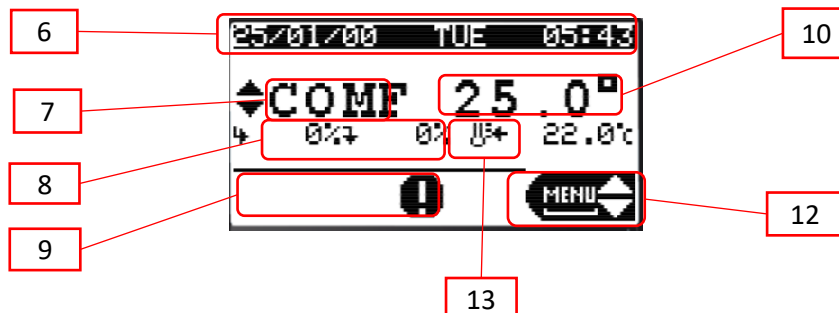

6	Current date and time.	12	HMI Advanced work module:
7	Current work profile		<ul style="list-style-type: none"> • Info" module (viewing the operating status of the control panel - available without logging in), • Set" module (change of settings of the operating parameters: capacity, temperatures, humidity, CO2 and setting of the timer - accessible without logging in), • Menu" module (allows configuration changes of the air handling unit and its components as well as programming of the EC motors, only available after logging in)
8	Current fan controls		
9	Air handling unit status (fans running/stopping, heating/cooling, activation of recovery)		
10	Current leading temperature value		
11	Lead temperature setpoint		
13	Operating status icon:		
	Opening/closing the throttles		Dehumidification
	Fan operation		Active recovery
	Heating		Detention on request
	Cooling		Emergency stop
	Moistening		Active calendar



- ! The parameters available in the LCD display window depend on the type of air handling unit and the application of the Controls system. Therefore, in the case of AHUs without a heater, you will not see the options related to the heating section.
- ! The HMI Advanced cannot be used as a room temperature sensor.

9.2.4 HMI BASIC 2HY

HMI BASIC 2 HY

The HMI Basic 2 HY is a basic control panel designed to operate VTS air handling units equipped with the uPC3 controller. The functions realised are:

- starting and stopping the control panel,
- operating mode selection,
- the possibility to view and change the parameters of individual operating modes (temperature, humidity, CO2 level, fan speeds of supply and extract fans),
- reading of the leading, external and room temperatures (built-in room temperature sensor),
- setting up AHU operation according to a schedule,
- alarm handling (viewing, deleting)

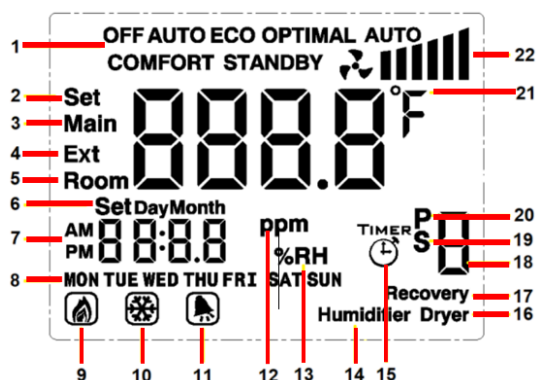

- | | | | |
|----|------------------------|----|---------------------|
| 1 | Current operating mode | 12 | Air quality |
| 2 | Setting temperatures | 13 | Moisture |
| 3 | Temperature leading | 14 | Moistening |
| 4 | Outdoor temperature | 15 | Daily schedule |
| 5 | Room temperature | 16 | Dehumidification |
| 6 | Date setting | 17 | Retrieved from |
| 7 | Clock | 18 | Option number |
| 8 | Day of the week | 19 | Special schedule |
| 9 | Heating | 20 | Interim schedule |
| 10 | Cooling | 21 | Temperature unit |
| 11 | Alarm | 22 | Fan operation level |

Current fan level control

Symbol	Fan control
	0 %
	0 < % ≤ 60
	60 < % ≤ 80
	80 < % ≤ 100

PUSH BUTTON	FUNCTION
	change of operating mode / change to setting menu / return to previous menu
	confirm selection / advance to next set-up parameters / return to general set-up menu
	switch between displayed temperatures / exit to main screen / switch off the screen
	changing parameter values





- ! In the absence of communication with the controller, the HMI Basic 2 HY will only display the current room temperature.
- ! Activation of the panel in the air handling unit controller settings The panel is intended for air handling units equipped with the uPC3 controller with software version 1.0.019 or higher. In order to activate its operation, it is necessary to go from the HMI Advanced (physical, connected to the controller's pLAN port, or virtual, being part of the visualisation application) to the service menu and, on the I01 screen, change the last digit of the application code to 7.
- ! The default Modbus address of the HMI Basic 2 HY is 16. It can be changed on the I05 HMI Advanced screen (HMI Basic 2 line).
- ! If there is no communication between the AHU controller and the HMI Basic 2 HY, only the room temperature will be displayed on the HMI screen and the controller will report the corresponding alarm (A1096).
- ! If there is no communication between the AHU controller and the HMI Basic 2 HY, only the room temperature will be displayed on the HMI screen and the controller will report the corresponding alarm (A1096).

START-UP OF THE AIR HANDLING UNIT - CHANGE FROM OFF TO ON PROFILE (ECO / OPTI / COMFORT)

On the main screen, hold down the button and **SET** then select one of the modes (**Eco / Opti / Comfort**) with successive presses and confirm the selection with .

SWITCHING THE PANEL ON AND OFF

To switch off the panel screen, hold down the ON/OFF button .  Switching on is done by briefly pressing the same button. Switching off the HMI panel is not the same as with switching off the panel - to switch off the AHU, select the Off mode.

The display backlight is automatically switched off after a user-defined period of time. The backlighting is activated by pressing any key. After backlighting, it is possible to carry out further operations with the panel.





CHANGING THE PARAMETERS OF INDIVIDUAL OPERATING MODES

On the main screen, hold down the button and **SET** then select the mode of interest (Standby / Eco / Opti / Comfort) with successive presses and confirm the selection with .

We now have the option of setting the parameter values associated with a particular mode:



- the set temperature,
- humidity,
- CO2 levels,
- supply fan speeds (S),
- exhaust fan speeds (E).



Access to individual settings depends on the configuration of the control panel and its actual components.

Changes are made with   confirmed with . Exit to the  home screen automatically after a moment of inactivity or by pressing .

SETTING THE OPERATING SCHEDULE FOR THE CONTROL PANEL

The HMI Basic 2 HY panel is equipped with the ability to set and modify the schedule of the air handling unit. Changes made from the HMIS BASIC 2HY panel also affect the schedule available in HMI Advanced and visualisation - it does not constitute a separate calendar, but allows full access to the existing one.

On the main screen, hold down the button and  then select the Auto submenu with  successive presses and confirm the selection with the  button.

One of the   schedules is now selected with the key:

- **Timer** -  daily schedule, allowing up to 4 mode changes to be programmed each day at a selected time, separately for each day of the week. Select in sequence: the day of the week, activation (On / Off) of each action, the time at which it is to be performed and the mode to be set. By confirming the successive parameters, you proceed to the parameterisation of the next action (the numbers 1-4 displayed on the right-hand side indicate the action you are currently setting).
- **P** - periodic schedule, allowing the selection of up to 3 periods per year during which the AHU is to operate in the selected mode (this type of schedule has a higher priority than the daily schedule). We select in turn: the activation (On / Off) of each period, its end date, start date and mode to be set. By confirming the successive parameters, we move on to the parameterisation of the next period (digits 1-3 displayed on the right-hand side indicate which period is currently set).
- **S** - special schedule, allowing the selection of up to 6 special days per year on which the AHU is to operate in the selected mode (this type of schedule has a higher priority than the daily and periodic schedules). We select in turn: the activation (On / Off) of each special day, its date and the mode to be set. By confirming the subsequent parameters, you move on to the parameterisation of the next special day (the digits 1-6 displayed on the right-hand side indicate which one you are currently setting).
- **T** - not used

! Access to individual settings depends on the configuration of the control panel and its actual components. Output

! Exit to the home screen is automatic after a moment of inactivity or by pressing .





ALARM HANDLING

The MI Basic 2 HY allows active alarms to be viewed and cleared. If an alarm is present, the bell symbol is shown on the main screen and the alarm number is displayed in place of the time.

The alarm is cancelled, once the cause of the alarm has been removed, by holding down  .

PROGRAMMING MODE

With the display switched off by holding down the button, hold down the button to enter the programming mode (change of advanced parameters).

Subsequent presses of **SET** toggle through the parameters and use   to set their value. The menu is automatically exited after a moment of inactivity or by pressing  .

Parameter	Scope	Default value	Description
IP	1-255	16	Modbus address
A1	2400/4800/9600	9600	Modbus - transmission speed
A2	0/1/2	0	Modbus - parity bit (0 = none, 1 = even, 2 = odd)
A3	12/24	24	Clock mode [h]
A4	00/01	00	Temperature units (00 = °C, 01 = °F)
A5	0-300	10	Screen backlight time [s]
A6	-9,9...9,9	0	Correction of the built-in temperature sensor [°C].

SPECIFICATION

Type of device	control panel; regulator
Temperature measurement	0°C ... 70°C, 10k NTC
Service	physical membrane keyboard keys
Communication	Modbus RTU (2400 / 4800 / 9600 bps)
Power supply	110-230V AC
Power consumption	1.5 VA
Display	backlit, graphic LCD
Design	ABS + polyester
Dimensions (H x W x D)	86 x 86 x 17 mm
Permissible operating temperature	0°C ... 50°C
Destination	for indoor mounting (IP20)
Assembly	in a standard Ø60 installation box on a mounting bracket
Mass	150g



- ! In the absence of communication with the controller, the HMI Basic 2 HY will only display the current room temperature.
- ! Activation of the panel in the settings of the air handling unit controller The panel is intended for air handling units equipped with the uPC3 controller with software version 1.0.019 or higher. In order to activate its operation, it is necessary to go from the HMI Advanced (physical, connected to the controller's pLAN port, or virtual, being part of the visualisation application) to the service menu and, on the I01 screen, change the last digit of the application code to 7.
- ! The default Modbus address of the HMI Basic 2 HY is 16. It can be changed on the I05 HMI Advanced screen (HMI Basic 2 line).
- ! If there is no communication between the AHU controller and the HMI Basic 2 HY, only the room temperature will be displayed on the HMI screen and the controller will report the corresponding alarm (A1096).
- ! If there is no communication between the AHU controller and the HMI Basic 2 HY, only the room temperature will be displayed on the HMI screen and the controller will report the corresponding alarm (A1096).

9.2.5 BLUETOOTH MODULE AND mHMI APPLICATION

The Bluetooth module is designed for low-power Bluetooth V5.0 connectivity to mobile devices. The module transmits an RS485 serial transmission signal [Modbus RTU] from the master controller to the mobile device using a Bluetooth connection, thus eliminating the transmission cable. To use the Bluetooth module to control the VTS Controls panel, install the dedicated mHMI application on the mobile device and connect to the dedicated mHMI Bluetooth module that has been connected to the VTS Controls panel. For VENTUS COMPACT Plug&Play devices, it is installed at the factory, while for other devices it requires connection and configuration by the customer.

BLUETOOTH MODULE

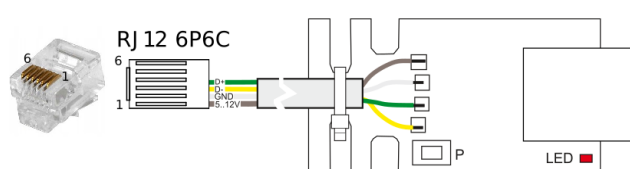
	Terminal	PIN	Designation
	0	=	earthing (shielded wire strand)
	1	1	+VRL 12V
	2	2	GND
	3	3	Rx-/Tx-
	4	4	Rx+/Tx+
	5	5	GNS
	6	6	+VRL 12V

Data transmission from RS485 [Modbus RTU] to Bluetooth V5.0.

Internally-built antenna - no external antenna required or connection possible.

Power supply

Degree of protection

Ambient temperature

ISM transmission

Dimensions

Assembly

Electromagnetic environments

Degree of environmental pollution

Development conditions

- Due to electrostatic discharge, it requires encapsulation so that the unit cannot be accessed during normal operation.
- Attach to the fixed installation elements of the unit. It should not be possible to bring the module close to live parts carrying dangerous voltages.

P button for configuration of serial communication data and pairing functions.

LEDs to indicate transmission and power supply.

5...12 VDC, 1 W (4A fuse)

IP 00

0° C...50 C°

Bluetooth V5.0, ISM 2.4 GHz, Transmission rate: 125 Kbps, 500 Kbps, 1 Mbps, 2 Mbps

60x22x5 mm

Stationary device for building in

Domestic or similar environments and industrial environments

2 acc. to IEC 62368-1

REQUIREMENTS:



- Controls software uPC3 from 1.0.26
- Smartphone with systems from versions: Android 9, iOS 11
- Assignment of rights and activation:
 - location (linked to a Bluetooth connection)
 - bluetooth connections

BT MODULE SUPPORT

The unit allows other units to connect via the broadcast system. The default name of the module by which it broadcasts is the factory number of the air handling unit. For devices with an unconfigured control panel number, the module reports as "AHU Bluetooth".

By default, the server only allows previously paired devices to connect, this status is indicated by an off LED with a pulse on.

You can allow all devices to connect by holding down the pairing button for approximately 3 seconds. The LED will then be on with the pulse off. The server can be connected to a maximum of one client device at a time.

A server that is actively connected to another device has its LED constantly on.

LED STATES:

- off - offline mode / no power,
- **disabled with pulse** - server mode with the possibility of connecting new devices disabled,
- **enabled with pulse** - server mode with connection of new devices enabled
- **enabled** - server mode with active connection



- The app includes a tutorial for pairing and connecting the device.

The mHMI smartphone application has been developed for service technicians as well as for end users of *VENTUS*, *VENTUS COMPACT* and *VENTUS COMPACT TOP* air-handling units. The app is available on: Play App Store and Apple App Store.

The application allows both the current change of settings and the detailed configuration of the operating parameters of the air handling unit and its components. The intuitive interface makes it easy to set up the basic functions of the control panel, making operation of the control panel a pleasure even for a user with no previous experience.

CONFIGURATION OF THE UPC3 CONTROLLER - mHMI and HMI ADVANCED

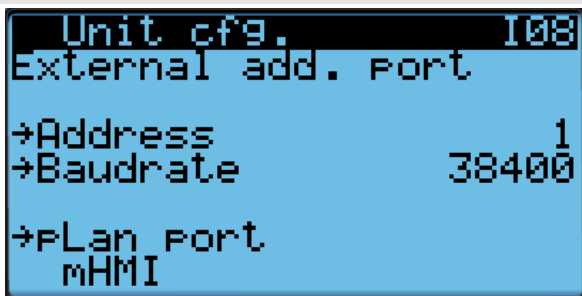

- "Address" - address of the controller used for external protocol communication
- "Speed" - speed (baudrate) of the external controller protocol
- "External port of the pLan controller" - type of protocol used by the controller's pLan port (RJ11 socket)

[for mHMI, the value of the pLan port parameter should be set to "mHMMI" accordingly].

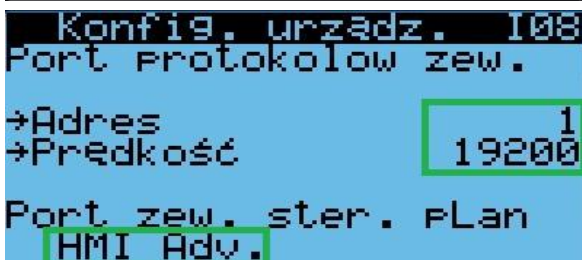

- "Address" - address of the controller used for communication using the external protocol
- "Speed" - speed (baudrate) of the external controller protocol
- "External port of the pLan controller" - type of protocol used by the controller's pLan port (RJ11 socket)

[depending on the HMI selected, the value of the pLan port parameter should be set accordingly on the HMI Advanced

- ! If a VENTUS COMPACT Plug&Play device has been ordered together with an mHMI module, it has the parameters set for mHMI operation.
- ! The ability to modify the page requires access to a standard service password. Set the parameters as shown in the illustration.

ACTIVATION OF THE BLUETOOTH MODULE

Remove the control panel junction box casing.

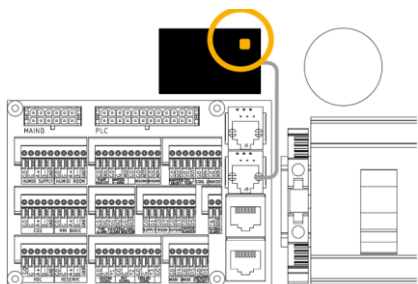

The BT module should be plugged into the T1 terminal.

If the BT module was ordered separately, plug it into the socket shown in the figure.

Find the button on the bluetooth (BT) module and press it until the LED starts flashing. This indicates that the BT is in pairing mode. Then go to the app and pair the control panel with the app. Pairing mode is active for 30s.

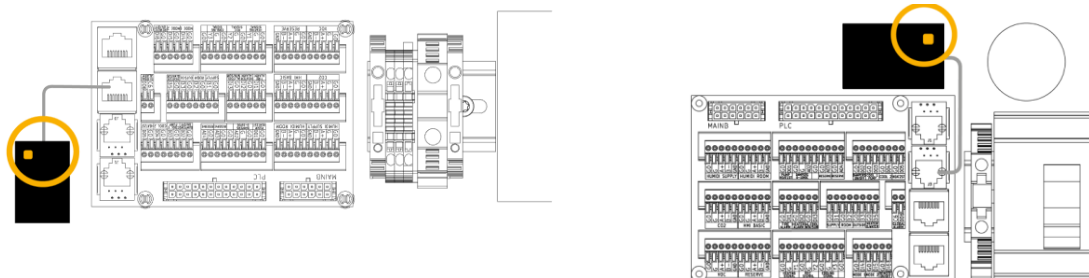

ADDING A DEVICE

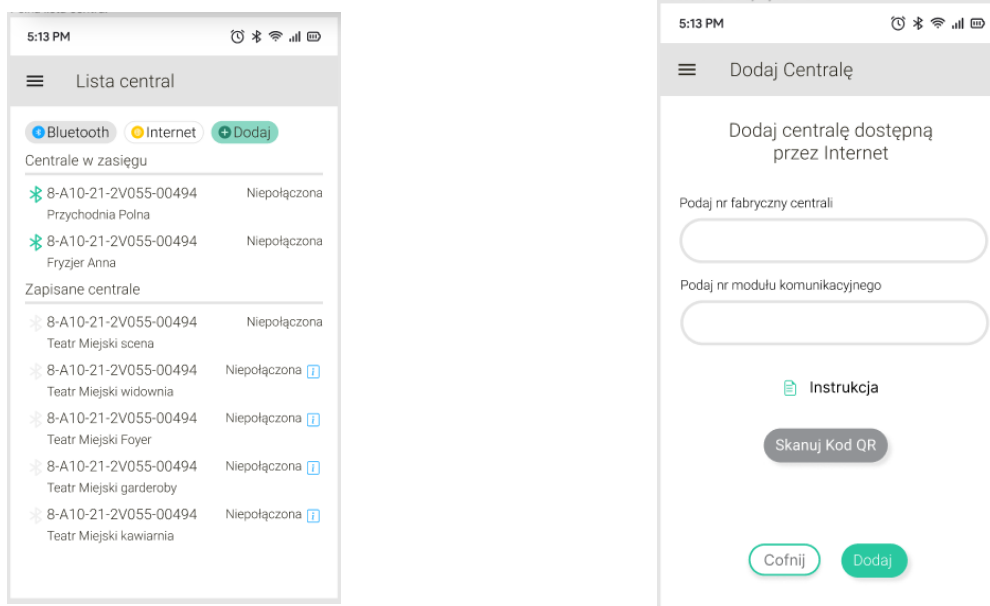

! If a Plug&Play VENTUS COMPACT device has been ordered together with an mHMI module, it already has a factory-programmed number in the application.

ACTIVATION OF THE DEVICE

Select a paired device

Then, in the Menu, select one of the operating modes Operation Mode "On":

- Eco
- Comfort
- Standby
- Auto

Save your selection

OVERVIEW OF SELECTED ASPECTS OF THE mHMI APPLICATION



- The app includes a tutorial for pairing and connecting the device.

PANEL OVERVIEW

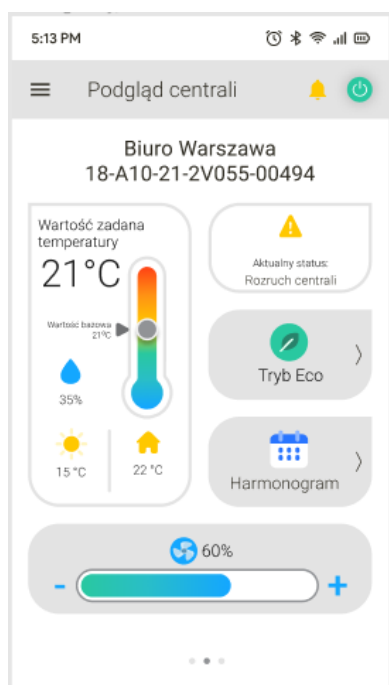

The PBX View contains the basic operating parameters of the PBX :

- outdoor air temperature,
- indoor air temperature,
- the set air temperature (of the lead sensor),
- degree of fan speed control,
- state of the panel,
- selected operation mode of the air handling unit: (eco, opti, comfort, auto, off)

Changing the target temperature

By clicking on the Thermometer icon, the user is able to continuously adjust the temperature within limits depending on the mode.

Changing the operating mode of the control panel

By clicking on the Modes icon, it is possible to change the current mode, as well as to change the settings for a particular mode.

Revision of the Work Schedule

By clicking on the Scheduler icon, it is possible to change the time settings with the assignment of modes to the harmonogram.

Changing fan speeds

In the bar at the bottom of the screen, it is possible to change the fan speed settings (within the settings specific to the operating mode). This can be done by clicking on + or - .

OPERATING MODE PARAMETERS

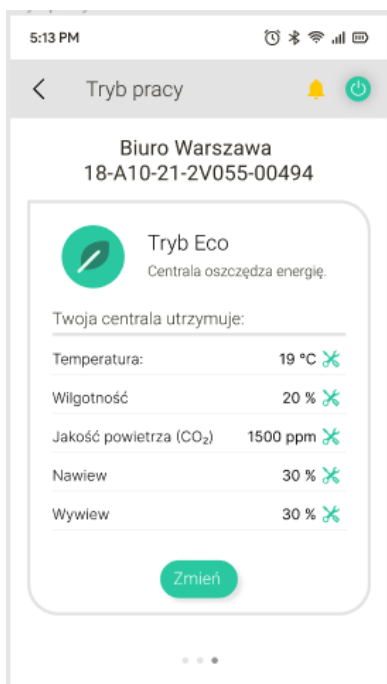

The Mode window presents the basic parameters relating to a particular mode and allows them to be edited quickly.

WORK SCHEDULE - CALENDAR

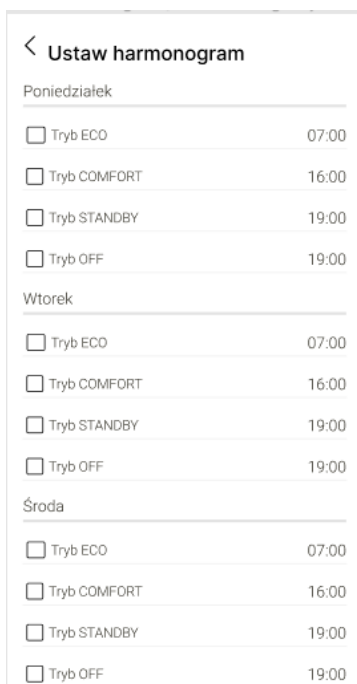
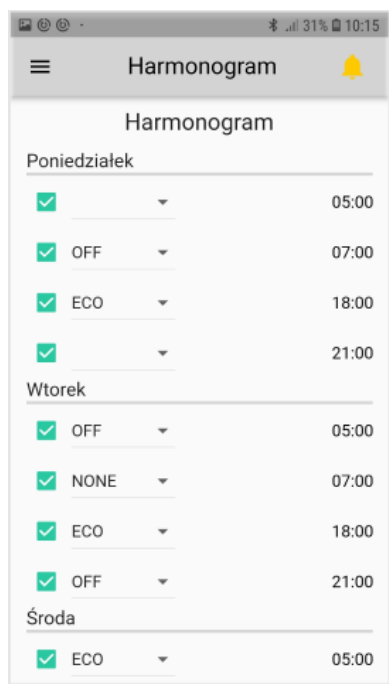

When the Schedule icon is selected, there is an option:

- to edit the days of switching on/off the control panel,
- to establish hourly intervals for the operation of the switchboard,
- assignment of the operating mode for a given time period .

ALARMS



The list of alarms is visible under the icon 

Alarms can be opened in one of two views:

- Current alerts,
- Historic alarms.

The list of historical alarms shows a preview of alarms that are not currently active.

If a situation occurs that affects to activate an alarm, it will be shown in the list of active alarms. The application screen will then turn red, to inform the user of the required response.

The 'Reset' button clears all alarms on the screen - current and historical.

If there is an active alarm, it will reappear in the current list.

FUNCTION SETTINGS - ADVANCED FUNCTIONS

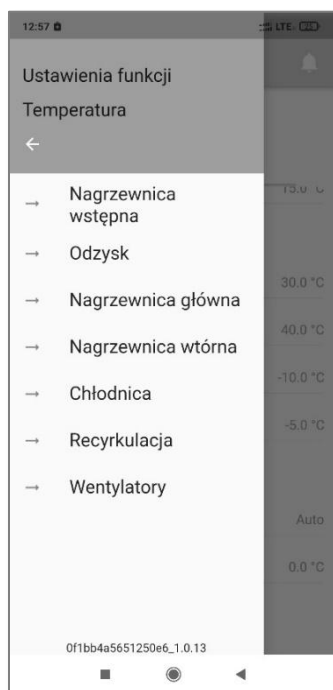

FUNCTION SETTINGS - this menu section gives you the possibility to view and edit the operating parameters of the associated control panel. In addition, it is possible to access the control of individual inputs and outputs located on the control panel and also on the expansion board.

TEMPERATURE - The temperature settings section contains settings for all possible components that affect the resulting supply temperature.

FUNCTION SETTINGS - ADVANCED FEATURES (cont'd)

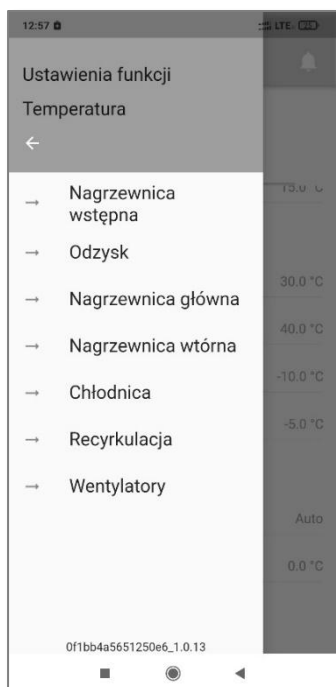

- **PRIMARY HEATER** - settings of the pre-heater operating parameters, e.g. PID, start and end points (if available in the air handling unit).
- **RECOVERY** - parameter setting for the heat exchanger.
- **MAIN HEATER** - settings of main heater operation parameters (if available in the control panel).
- **RE-HEATER** - settings of re-heater operation parameters (if available in the control panel).
- **COOLER** - settings of the cooler operation parameters (if available in the air handling unit).
- **RECYCLATION** - settings for the air recirculation function (if available in the unit).
- **FANS** - settings including fan speed, PID algorithm, fan start and stop delay time. CAV/VAV control.
- **MOISTURE** - possibility of setting, among other things, the PID parameters of the humidification process, extreme points for the start and end of humidification.

FUNCTION SETTINGS - ADVANCED FEATURES (cont'd)

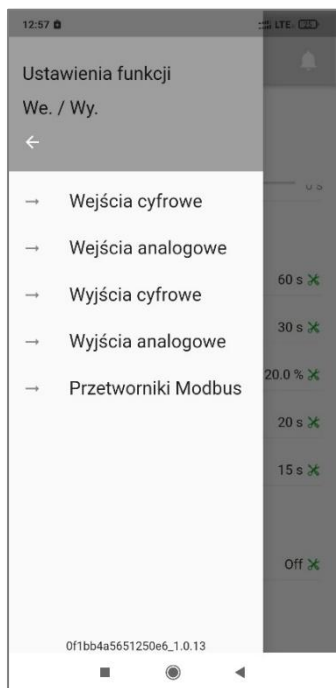

I/O. - Configurable digital and analogue inputs and outputs as well as ModBus signals. and analogue inputs and outputs as well as ModBus signals. The inputs and outputs are labelled with the functions they are assigned, e.g. D11 - Fire alarm - is the digital input responsible for the fire alarm.

- Digital inputs,
- Analogue inputs,
- Digital outputs,
- Analogue outputs,
- Modbus transducers - ability to view and edit parameters relating to transducers: pressure, humidity, CO2,

FUNCTION SETTINGS - ADVANCED FEATURES (cont'd)

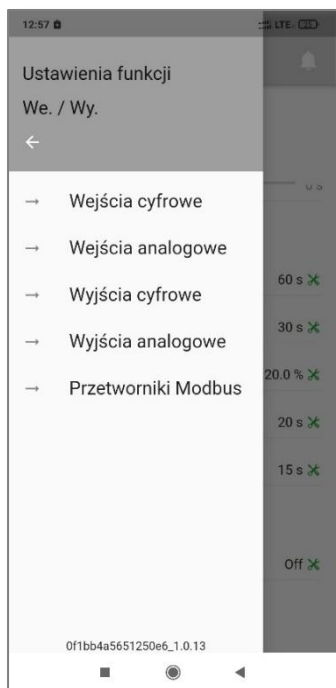

I/O EXPANSION MODULE

- Main board - allows the reading of the parameters of the signals connected to the main board of the control panel, the activation/deactivation of the expansion board, as well as the setting of values such as: maximum pressure values, pressure offsets,
- EC PCB - it is possible to change the settings of the inputs and outputs present on the PCB
- HMI Basic - allows the settings for the HMI Basic panel to be edited

UNIT

- Adjustment
- BMS - variables used for communication with BMS systems
- Access levels - there are 3 levels of access: user, service technician and manufacturer.

MONITORING

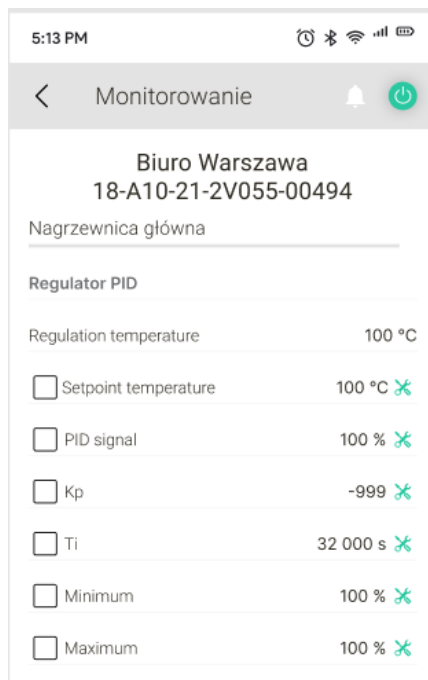

MONITORING

The user can define a quick-view list of selected parameters.

To use this functionality, the user must save the selected parameters in the **MONITORING** section

APPLICATION SETTINGS

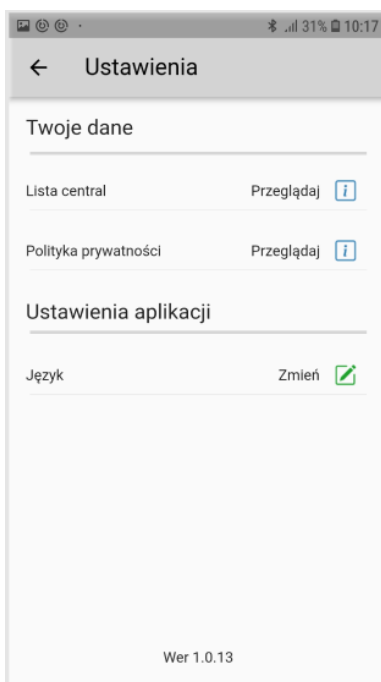
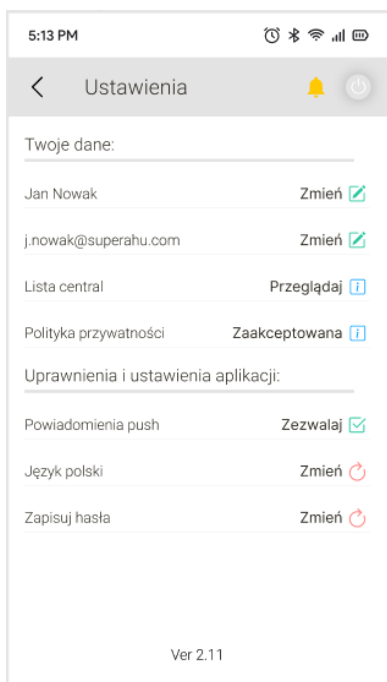

APPLICATION SETTINGS

General settings section, which is not related to operating parameters. Here it is possible to min:

- give the connected PBX its own name,
- display a list of the exchanges saved and currently detected by the Bluetooth module,
- changing the language of the application,
- restore the panel to factory settings,
- changing the display units for parameters.

9.2.6 OPERATING MODES OF THE CONTROL PANEL

OPERATING MODES OF THE CONTROL PANEL	
OFF	Air handling unit switched off - fans stopped, air dampers and control valves closed all sensors and measuring devices remain active - to protect the unit from damage, e.g. fire alarm, anti-freeze protection.
AUTO	Panel operation dependent on calendar programming
LOW	Lower economy mode - Fan speed as well as the dead zone in temperature control are adjustable. The temperature control algorithm can use a wide dead zone, while the fans can be set to low speed to reduce energy consumption.
EKON	higher economy mode - The fan speed as well as the insensitive zone in the temperature control are adjustable. The temperature control algorithm can use a narrower insensitive zone, while the fans can be set to a higher speed to optimise energy consumption.
COMFORT	Factory setting of selection parameters. The settings can be modified by the user.
HMI BASIC	Basic mode - external control signals (binary inputs) of critical temperatures, e.g. too low a temperature, trigger the control unit and immediately heat the room.

9.2.7 VERIFICATION OF OPERATION DURING INITIAL START-UP

During the initial start-up, it is recommended that the steps listed below be carried out.

CHECKING THE OPERATION OF THE FANS

Check that the fans do not make excessive noise (make sure that the impeller does not rub against the hopper and that there are no foreign bodies within the fans' operating range, which may be caused by improper transport or storage conditions),

CHECKING THE OPERATION OF THE AIR DAMPERS ACTUATORS

- Check that they close and open completely without resistance (this can be done by observing their operation during start-up/shut-down of the air handling unit or by pressing the button on the actuator to release its locking mechanism and moving the blades manually),
- Check that they open and close in the correct direction (dampers should open when the control panel start-up sequence is activated and close when the control panel is deactivated - check that they are operating in the correct sequence at the time - the actuators are equipped with a button to change direction in the event of wrong direction),
- For actuators with 0-10V signal, it is necessary to check if they operate correctly in their full range (0-10V actuators are always used for passive bypass of recovery and mixing chamber dampers - in case of air handling units with a mixing chamber, additionally supply and exhaust dampers can also be steplessly regulated by 0-10V voltage). - this can be done by observing its operation during the air handling unit's operation or manually feeding the control signal to the relevant screens of the mixing or recovery chamber controller (set D to ON and A to the selected percentage value).

```
S Mixing Damper E01
Eco damper
CONTROL SIGNALS
→Manual D AUTO A AUTO
```

```
S Recovery D01
Recovery device
CONTROL SIGNALS
→Logic ~ Off NC
→Manual D AUTO A AUTO
COUNTER
→Hours 0h
→Reset NO
```

CHECK OF SENSOR READINGS

- check if the readings from temperature, pressure, CO2 and humidity sensors are correct (at the beginning, when the air handling unit is powered but not operating, temperatures sent to the controller from temperature sensors should oscillate within the ambient temperature range of the air handling unit's air, while the remaining transmitters and sensors should show typical values for the given environment - e.g. most often for the CO2 sensor it will be values below 600ppm for fresh air and initially zero values of flow and pressure before starting the fans on transmitters' pressure, their values should change accordingly within the expected range once the unit is set up for operation).

```
I/O status Sc01
Temperatures
B1 Supply 0.0°C
B2 Return 0.0°C
B3 External 0.0°C
B4 Recovery 0.0°C
B5 Water heat 0.0°C
```

```
I/O status Sc02
Temperatures
B6 Rec. Supply 0.0°C
Water Preheat 0.0°C
After Preheat 0.0°C
TH Room 0.0°C
```

```
I/O status Sc03
Humidities
Room 0.0%rH
Supply 0.0%rH
Return 0.0%rH
```

```
I/O status Sc04
Pressures
Supply 0.0Pa
Return 0.0Pa
```

```
I/O status Sc05
Return CO2 value 0.0PPM
```

```
I/O status Sc38
Pressure filters
Supply 0.0Pa
Supply 2 0.0Pa
Supply 3 0.0Pa
Return 0.0Pa
Return 2 0.0Pa
```

CHECKING THE OPERATION OF THE WATER HEATER VALVE ACTUATORS

Check that the heater valve actuator responds to the control signal - manually actuate the valve from the controller's service menu and observe whether it causes the valve to open/close accordingly.

To do this, set parameter D to ON and parameter A to the desired percentage in the corresponding screen in the service menu, depending on the type of heater you have and the function it performs [screens A01, A03, A05, A06. (See "DESCRIPTION OF THE UPC3 CONTROLLER MASKS")

CHECKING THE OPERATION OF THE WATER HEATER CIRCULATION PUMP

Check that the heater circulation pump responds to the control signal - manually set the valve from the controller's service menu and observe whether it causes the pump to switch on/off accordingly.

- ! Remember to restore the original settings of the D and A (Auto) parameters after the test.

9.2.8 MEASUREMENT OF AIR VOLUME

The measurement of air volume is an essential measurement for:

- commissioning and technical acceptance of the air handling unit,
- if the system does not perform as required and expected,
- periodically check the operation and efficiency of the air handling unit,
- replacement of fan assembly components.

Before taking measurements and making adjustments, make sure, that the dampers on all grilles or gates are positioned as designed.

Determination of the amount of airflow is most often based on the measurement of the average airflow velocity in a test cross-section of a duct. One of the most common methods for determining the average flow velocity is the cross-sectional sounding method using a Prandtl tube and the measurement of the flow velocity-related mean dynamic pressure.

Key factors that affect measurement accuracy are:

- the position of the cross-section to be measured in relation to the elements causing distortion of the flow velocity (elbows, orifices, tees, butterfly valves, etc.),
- the number and location of test points in the cross-section to be measured,
- stable and constant airflow,

The measurement must be carried out in a section of duct with parallel walls and straight sections at least 6 times the hydraulic diameter of the duct or the corresponding diameters upstream of the test point and no less than 3 diameters downstream of this point. In a real ventilation system, finding such a long straight section may be a problem. In this case, the position of the cross-section should be determined at the point where the least flow disturbance is expected, increasing the number of measurement points. The location of the measuring cross-section should be determined at the system design stage.

An estimate of the measurement result is considered sufficient if it does not differ by more than $\pm 10\%$ from the design value. In the case of greater discrepancies, an approximation of the measurement result to the design value may be obtained by:

- adjustment of the ventilation duct network,
- changing the setting of the main throttle,
- changing the fan speed

9.2.9 THE MOST COMMON ADAPTATIONS OF PARAMETERS TO THE NEEDS OF THE FACILITY

FUNCTION	SCREEN	SCOPE OF THE CHANGES	WHEN TO CHANGE
MAIN HEATER	A07	PID	unstable temperature control
DXH MAINTAIN	A11	compressor switch-on thresholds	unstable temperature control
SECONDARY HEATER	A12	PID	unstable temperature control
PRE-HEATER	A16	PID, post-heat temp. settings, min/max power	unstable temperature control
MAIN RADIATOR	B03	PID, min/max power	unstable temperature control
DX MAINTAIN	B05	compressor switch-on thresholds	unstable temperature control
VENTILATORS	C16	PID	unstable temp. control
VENTILATORS	C16	setting of capacity dependence on temp. reg.	matching of object properties
RECOVERY DEVICE	D02	PID, min/max power	unstable temperature control with heat recovery
RECOVERY DEVICE	D03	PID	unstable temperature control with cooling recovery
MIXING CHAMBER	E02	PID in the heating direction	Unstable temperature control with inefficient heat source
MIXING CHAMBER	E03	PID in cooling direction	Unstable temperature control with inefficient heat source
GENERAL	H01	min/max temp, min/max temp setting	matching of object properties
VENTILATORS	H02	PID efficiency depending on temp. reg.	unstable regulation of performance on temperature
GENERAL	H03	heating/cooling switchover thresholds	unstable temperature control
GENERAL	H04	StdBy" mode parameters	matching of object properties
GENERAL	I02	selection of the leading temperature	matching of object properties
N VENTILATORS	C07	PID`	unstable capacity regulation
FANS W	C08	PID	unstable capacity regulation
CO2			
VENTILATORS	C12	PID	unstable co2 control by changing output
VENTILATORS	C12	setting the performance relationship to the CO2 reg.	matching of object properties
MIXING CHAMBER	E04	PID	unstable co2 control by changing recirculation
MIXING CHAMBER	E06	parameters of the "rapid heating" function	matching of object properties
HUMIDIFIER	F02	PID	unstable humidity control
BED HUMIDIFIER	F03	humidifier on/off threshold	unstable or inaccurate humidity control
GENERAL	I02	selection of the leading moisture content	matching of object properties
HMI BASIC	I05	Sensor activation in the HMI Basic	adaptation to the needs of the site
DXH MAINTAIN	A10	compressor run-time setting	
DXH INTRODUCTION	A14	compressor run-time setting	
DXH INTRODUCTION	A18	compressor run-time setting	
CENTRAL	A21	next min. air temp. and switch-off delay.	object sensitive to low air temperature

FUNCTION	SCREEN	SCOPE OF THE CHANGES	NOTES
PRE-HEATER	A29	supply air heating support	object sensitive to low air temperature
CENTRAL	A21	next min. air temp. and switch-off delay.	object sensitive to low air temperature
DX MAINTAIN	B04	compressor runtime setting	
VENTILATORS	C11	fire settings	matching of object properties
RECOVERY DEVICE	D06	set. share of defrosting methods	Lack of heat source capacity or object sensitive to reduction of discharge capacity
MOISTURIZER	G08	humidifier alarm - logic	matching the properties of the humidifier
DIGITAL INPUTS	G07	fire entrance.	matching the characteristics of the fire installation.
DIGITAL INPUTS	G07	heating, cooling alarm	adjustment to the characteristics of the foreign heating/cooling source
DIGITAL OUTPUT	G09	Collective alarm logic	adaptation to the needs of the site
REC. MAIN ELECTR.	A09	setting the power distribution of the heaters	configuration setting
REC. ELECTR.	A13	setting the power distribution of the heaters	configuration setting
REC. PRE ELECTR.	A17	setting the power distribution of the heaters	configuration setting
DXH	A22	aggregate control signal scaling	matching the characteristics of the cooling source
DXH	A23	set min. temp.	matching the characteristics of the cooling source
VENTILATORS	C05	set. vent. type. and. nominal. output.	
VENTILATORS	C06	Pressure settings for VAV controllers	matching of VAV controllers
RECOVERY DEVICE	D03	activation of cooling recovery	
MIXING CHAMBER	E05	min/max working range setting	min - minimum air exchange required in the facility, max - installation of intake and discharge less than N and W
MIXING CHAMBER	E07	set. working method for individual profiles	adaptation to the needs of the site
STEAM HUMIDIFIER	F01	logic of operation, plausibility check	humidifier outside the VTS range
DIGITAL INPUTS	G08	remote AHU profile setup (setting profile type and NC/NO logic)	adaptation to the requirements of the facility
DIGITAL INPUTS	G08	Input logic External summer/winter mode override	adaptation to the requirements of the facility
DIGITAL OUTPUT	G09	glycol recovery pump start-up logic.	matching the control characteristics of the glycol pump
DX, DXH	G10	logic of outputs ON stage I and II heating/cooling.	matching the characteristics of the cooling source
MOISTURIZER	G11	logic of work permit exit	matching the properties of the humidifier

FUNCTION	SCREEN	SCOPE OF THE CHANGES	COMMENTS
PRE-HEATER	G11	logic of work permit exit	matching the properties of the heater
SECONDARY HEATER	G11	logic of work permit exit	matching the properties of the humidifier
TRANS. VENT. REDUN.	G11	logic of work permit exit	adjustment to control characteristics throughput.
PROCESSED. PRESS. FILTERS	G18	activation of transducers	additional air filters
ADDITIONAL FILTERS.	G20	type of filter	additional air filters
ADDITIONAL FILTERS.	G21	max. pressure drop	additional air filters
CONTROLLER	I02	progr./operation mode switchover	AHU configuration change, first start up????
VENTILATORS	I03	type of control CAV/VAV/ none	matching the properties of the ventilation system
HMI BASIC	I05	alarm reset authorisation from HMI Basic	adaptation to user requirements
CONTROLLER	I11	export/import of controller settings	parameterisation of several identical AHUs, archiving of settings
HMI BASIC	J03	activation, address	
FILTERS	J09	type, max. pressure drop	Changing the filter type, adapting to the needs of the object
VENTILATORS	J11, J12	set. control external analogue signal	adaptation to the needs of the facility
HMI, PLC	I06	selection of schedule source (Basic/uPC/none)	customisation
LEVEL OF ACCESS	K01	logout	end of setting change
AHU	Sa01	preview of current AHUs	
AHU	Sa03 to S07	changes to the settings of the current parameters	current needs of the facility
HMI	Sa08	setting the date and actual time	
HMI	Sa09 to Sa11	setting the work schedule	customisation
TEMP.	G05	B1 and B3 calibration	cable length > 5 m

10 READING AND CONFIGURATION OF PARAMETERS

10.1 uPC3 Screens Description

A full description of the uPC3 controller masks is available in the dedicated manual "AHU uPC3 Controller Masks Description upc3"

10.2 READING OF HEAT PUMP PARAMETERS

HMI ADVANCED

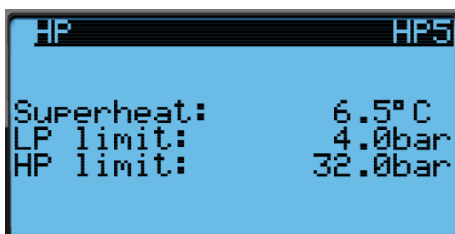
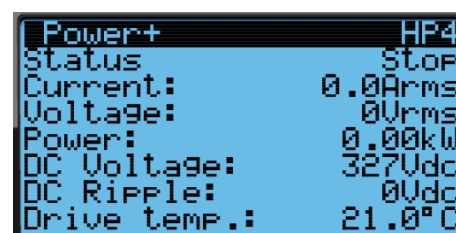
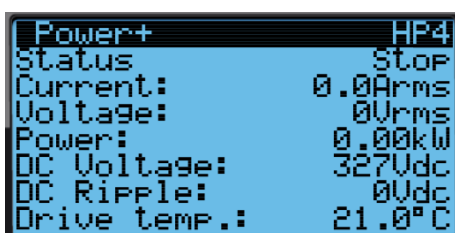
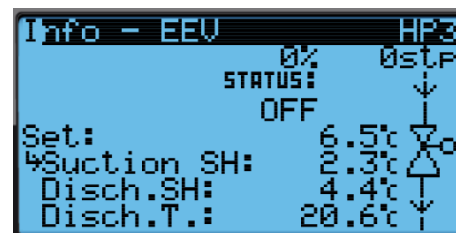
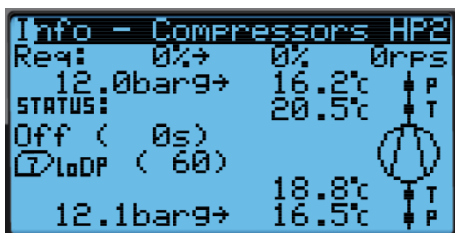
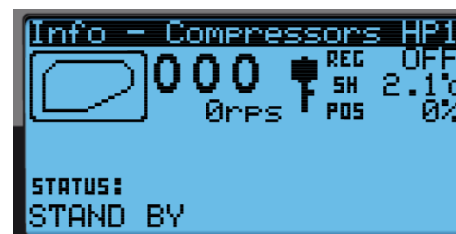
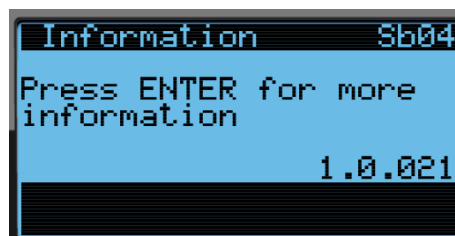
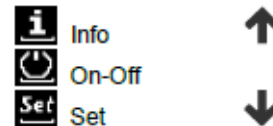

WEB HMI

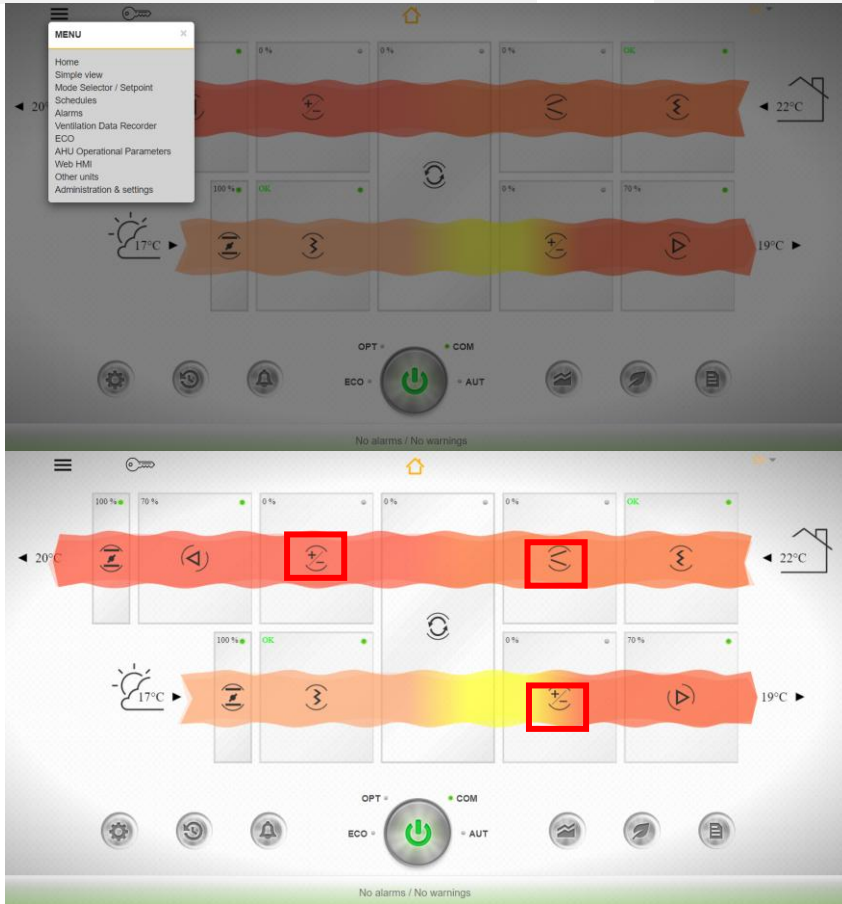

Web HMI

Web HMI

11 MAINTENANCE

11.1 MAINTENANCE



- ! The basic technical data of the air handling unit, such as the type, parameters and dimensions of the most essential components (filters, heat exchangers, fans, electric motors), can be found in the technical data sheet that is supplied with each unit.
- ! All maintenance work on air handling units should be carried out with the unit switched off. To ensure safe operation of the unit, the service switch, which cuts off the power supply to the motor during maintenance work, must be installed outside the fan section. Disconnection of the power supply circuit by the service switch must take place in a de-energised state. The service switch should be located near the inspection panels of the fan section.
- ! Thorough and regular maintenance as well as technical inspections of air-handling units and their components are essential in order to identify faults at an early stage - before more serious failures and damage occurs.
- ! This documentation only covers general guidelines for inspection intervals to ensure fault-free operation of the units under the various possible external operating conditions. The technical inspection intervals must be adapted to the local conditions (level of contamination, number of start-up cycles, loads, etc.).

HEAT PUMP SYSTEM



- ! **REMEMBER THE ENTRIES IN THE DEVICE CARD!**
- ! The F-gas regulation requires refrigeration system operators to keep records of legally mandated leakage checks. The records must be kept by the system operator and the staff or company carrying out the inspections for at least five years.
- ! Of particular importance are the case records in relation to leakage checks. They must include the following information:
 - All quantities of F-gases added during activities such as installation, maintenance, servicing or spill response,
 - Name and address of the recycling or reclamation facility (including certificate number, if applicable) if recycled or reclaimed F-gases are used,
 - All quantities removed and remediated,
 - The company that worked on the equipment (with certificate number, if applicable),
 - Leakage control results (retesting),
 - In case of system decommissioning: measures taken to recover and dispose of fluorinated greenhouse gases.

If the throttle is dirty and does not operate freely, it should be cleaned according to one of the following methods:

- using a Hoover with a soft suction nozzle,

- by blowing with compressed air,
- washing with water and non-corrosive cleaning agents for aluminium.

After re-installation, the damper should be carefully sealed, above all on the outside air intake side, to prevent the water heater from freezing.

MINIMUM SCOPE OF PERIODIC INSPECTIONS	
1	Verification of the operating time of the heat pump and, based on this, an assessment of the operating status of the unit
2	Interview with the user - writing down comments of use
3	Alarm history overview - indication of stored alarms
4	Site visit (checking the general condition of the unit, e.g. excessive icing, assessing sound levels, patency of exchanger fins),
5	Check for leaks in the refrigeration circuit. If there are indications of refrigerant loss (e.g. oil stains on the hoses or compressor plate); check with a leak detector
6	Checking the condition (replacement) of the filter drier
7	Checking (cleaning, repairing) the patency of the heat exchanger fins - supply air
8	Checking (cleaning, repairing) the patency of the heat exchanger fins - exhaust
9	Measuring system pressure at standstill
10	Measurement of system pressure during operation
11	Control of the heat pump's operating parameters (maintaining adequate temperature differences in the lower and upper heat sources).
12	Checking the operation of the appliance components (i.e. switching valves, electric heater, safety devices),
13	Checking that the electrical connections are properly seated and that the bolted connections of the electrical cables - power and Controls - are securely fastened
14	Electrical connection - checking for correct voltages and currents

MULTILEAF AIR DAMPERS

If the throttle is dirty and does not operate freely, it should be cleaned according to one of the following methods:

- using a Hoover with a soft suction nozzle,
- by blowing with compressed air,
- washing with water and non-corrosive cleaning agents for aluminium.

After re-installation, the damper should be carefully sealed, above all on the outside air intake side, to prevent the water heater from freezing.

AIR FILTERS

- Under standard operating conditions for air handling units, filters should be changed approximately twice a year. The need to change the filter (in addition to visually visible contamination) is also indicated by a drop in pressure:
 - EU4 - 150Pa,
 - EU5, EU7 - 200 Pa,
 - EU9 - 300 Pa
- If the final differential pressure exceeds the design value, the filter must be replaced. The filters are disposable components.
- When replacing the filter, the filtration section should also be cleaned - either with a Hoover or by dry cleaning.
- When ordering a new filter set from an authorised VTS office, specify the type of filter, the filtration class, the size of the air handling unit and, if necessary, the size of the filter, as specified on the technical data sheet or in the "AIR FILTERS" section.
- Incorrect or contaminated filters can cause an increase in the power consumption of the fan motors, leading to damage to the drive motors.

WATER HEATER

- Active water heaters should be equipped with anti-freeze systems. Optionally, a non-freezing heating medium (e.g. glycol solution) can be used in winter. If the heating medium is cut off or the air handling unit is at a standstill, and if the air temperature is likely to fall below + 5°C, the heater should be drained. To do so:
 - close the heating medium inlet and outlet valves (isolate the heater from the heating system),
 - remove the inspection panel,
 - unscrew the drain and remove the vent plug from the collectors,
 - connect the output hose to a drain, allowing water to run off the drained exchanger outside the unit,
 - blow compressed air through the vent plug into the heater,
 - repeat this procedure several times in short intervals until there are no visible drops of water coming out of the drain hose,
 - screw the drain plug and vent plug back in.
- Check the level of dirt on the heater plates at least once every four months. Dust settling on the surface of the heater causes a deterioration of its heating power and leads to a pressure drop on the air side. Even if the air handling unit is equipped with filters, over time dust, supplied with the delivered air, settles on the heater plates. If the plates become dirty, their cleaning should be carried out in one of the following ways:
 - using a Hoover with a soft suction nozzle on the air inlet side,
 - by blowing with a jet of compressed air against the direction of normal air flow, directing the jet parallel to the tiles,
 - washing with warm water and non-corrosive cleaning agents for aluminium or copper components.
- Protect adjacent sections of the air handling unit from contamination before cleaning.
- In order to achieve the maximum heating capacity of the heater, it must be well vented. For this purpose, vent plugs have been designed, located on the heater manifolds.
- When the unit is stationary, the flow of the heating medium should be limited to a minimum so that the temperature inside the unit does not exceed +60°C. Exceeding this value could cause

damage to some components or subassemblies (motor, bearings, plastic parts, etc.) installed in adjacent sections.

ELECTRIC HEATER

- The electric heater battery consists of bare heating coils. During operation of the air handling unit, when the heater is switched off, dust may settle on the heating coils. When the heater is restarted, heavy contamination of the surface of the heater can generate unpleasant burning dust odours, even leading to an initial fire hazard.
- Check all electrical connections, the condition of the heating elements and the level of dirt on a regular basis (every 4 months) and especially before the start of the heating season. Any dirt should be removed with a Hoover with a soft tip or compressed air.
- The operation of the overheating protection system in the absence of air flow should also be checked. The air flow velocity should not be less than 1.5 m/s.

FREON HEATERS AND COOLERS

- Maintenance of the freon cooler covers the same range of operations as maintenance of the heater and water cooler. Before washing the freon cooler with warm water, the cooling system should be emptied by draining the freon into a container. Otherwise, there will be a risk of an uncontrolled increase in freon pressure, causing damage to the cooling system.

EXCHANGER ROTARY

- During maintenance operations on the rotary exchanger, check that:
 - the rotor turns freely. Excessive resistance may be caused by the sealing brushes being pressed too far against the edge of the rotor. In this situation, adjust the brushes accordingly. A worn seal must be replaced. If a previously removed seal is to be reinstalled, it must be installed so that its direction is in line with the rotor's direction of rotation. After replacing or adjusting the sealing brushes, the exchanger should be allowed to run for 30 minutes to allow the brushes to fit to the rotor surface.
 - Check afterwards:
 - motor current and compare it with the rated current to find out whether the motor is overloaded.
 - that the drive belt is not damaged and that it is clean and not slipping on the cylindrical part of the rotor. If belt slippage still exists despite maximum tension on the tensioning system, the belt should be replaced or shortened,
 - that the air intake openings are not covered with dust or otherwise contaminated. Any dirt should be removed with a soft-tipped Hoover or compressed air.
- The rolling bearings of the rotor and drive motor are lubricated continuously during operation. The amount of grease in the bearings during installation of the exchanger is sufficient for long-term operation and there is no need to lubricate the bearings during operation. It is recommended that the motor and gearbox are cleaned of dust so that an insulating layer does not form on the motor surface, which can lead to an increase in the operating temperature of the drive.
- This exchanger should be inspected every four months and the inspection should cover the technical condition as well as the level of fouling. The accumulation of dirt in the heat exchanger fins is often limited to the first 50 mm in the exchanger. Prior to cleaning, adjacent sections of the air handling unit should be protected from contamination.
- The necessary cleaning should be carried out as follows:
 - using Hoovers with a soft suction nozzle,
 - by blowing the ducts with a jet of air against the direction of normal air flow,

- washing the air ducts along their entire length with water and non-corrosive aluminium cleaning agents,
- In the case of very dirty exchangers, a pressurised water jet can be used to clean them.
- When cleaning the exchanger with mechanical means, maximum care must be taken not to damage or deform the exchanger panels.
- When operating the exchanger at temperatures below zero, it must be thoroughly dried after cleaning before being put back into operation.
- Inspection and maintenance of the rotary exchanger drive must be carried out at the following intervals:
 - 12 hours after start up,
 - 1 week after start up,
- at least every 3 months thereafter

SOUND ATTENUATORS (DAMPING BAFFLES)

The silencer section is fitted with baffles made of non-combustible mineral wool to absorb acoustic energy. Maintenance procedures include checking the contamination level of these baffles.

FAN UNIT

- Before carrying out any work (repair, maintenance, service) on the air handling unit, especially when opening inspection panels in the fan section and when removing covers over the drive system, ensure that:
 - the appliance has been properly disconnected from the power supply. This applies to both primary and secondary circuits,
 - rotor does not rotate,
 - The fan surfaces are cool and temperature-safe to the touch,
 - the fan is protected against unintentional start-up.
- The fans are designed for dust-free air flow or air with a light dust content. They are not designed to operate with aggressive gases, vapours or in a highly dusty environment. Operating the fans in an unsuitable environment can lead to bearing damage, corrosion, impeller imbalance or vibration.
- The fan and motor of the unit are designed to meet specific requirements and for special operating characteristics. The fan speed is set so that the air flow and the total impeller stress concentration are appropriate for the ventilation system. A lower forced air flow rate causes operational disturbances and leads to an imbalance of the entire ventilation system.
- This can be caused by:
 - dust deposition on the fan impeller blades,
 - Wrong direction of fan rotation. If the centrifugal fan rotates in the wrong direction, the air flow causes significantly harmful effects.
- When performing maintenance on the fan, check that:
 - the rotor turns freely, - the rotor is properly balanced,
 - the rotor is securely mounted on the journal,
 - has not changed position in relation to the inlet cone,
 - all fixing screws of the fan components are tightened.
 - rotor imbalance can be caused by:
 - dust deposition on the rotor blades,
 - detachment of additional balancing weights,
 - damage to the rotor blades.
- The contamination level of the inside of the casing, rotor and motor should be checked every four months.

- Cleaning should be carried out by vacuuming or wiping all surfaces with a wet cloth. For more serious soiling, nylon brushes can be used:
 - the inside of the casing using a Hoover,
 - rotor with a Hoover or by damp wiping with a cloth dampened in a soft cleaning agent.

11.2 CONSUMABLES

SKANUJ I KUP

ZESKANUJ KOD QR NA SWOJEJ CENTRALI LUB
ZNAJDZ ZESTAW FILTRÓW PO NUMERZE URZĄDZENIA

KUP ZESTAW FILTRÓW
ONLINE
www.eshop.vtsgroup.com

! Spare parts are available from the manufacturer's online shop and from the network of authorised service centres www.eshop.vtsgroup.com.

! Simply enter the factory number

MINI-PLEAT AIR FILTERS

A x B x L	438 x 361 x 48	438 x 493 x 48	542 x 493 x 48	416 x 309 x 48	463 x 370 x 48	523 x 419 x 48	600 x 438 x 48	496 x 489 x 48	
VVS021c	2								ePM10 40% (EU5) ePM2,5 65% (EU7) ePM1 80% (EU9)
VVS030c		2							
VVS040c			2						
VVS055c				6					
VVS075c					6				

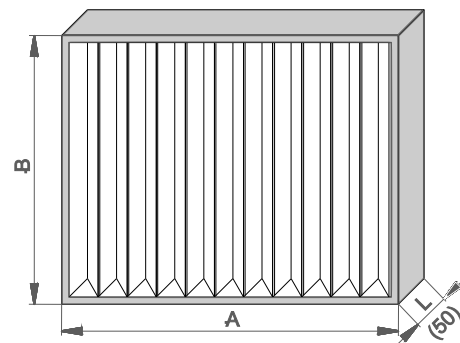

BAG AIR FILTERS 600mm

A x B x L	428 x 287 x 600	428 x 428 x 600	490 x 490 x 600	592 x 592 x 600	592 x 287 x 600	ISO ePM 2.5 65% (EU7) ISO ePM 1 80% (EU9)
VVS021c	2					
VVS030c		2				
VVS040c			2			
VVS055c				2		
VVS075c	3	3				

BAG AIR FILTERS 300mm

A x B x L	428 x 287 x 600	428 x 428 x 600	490 x 490 x 600	592 x 592 x 600	592 x 287 x 600	ISO COARSE 80% (EU5) ISO ePM 2.5 65% (EU7) ISO ePM 1 80% (EU9)
VVS021c	2					
VVS030c		2				
VVS040c			2			
VVS055c				2		
VVS075c	3	3				

11.3 CONNECTION DIAGRAM OF THE DEVICE

11.3.1 VENTUS COMPACT HP AHU (1/11)

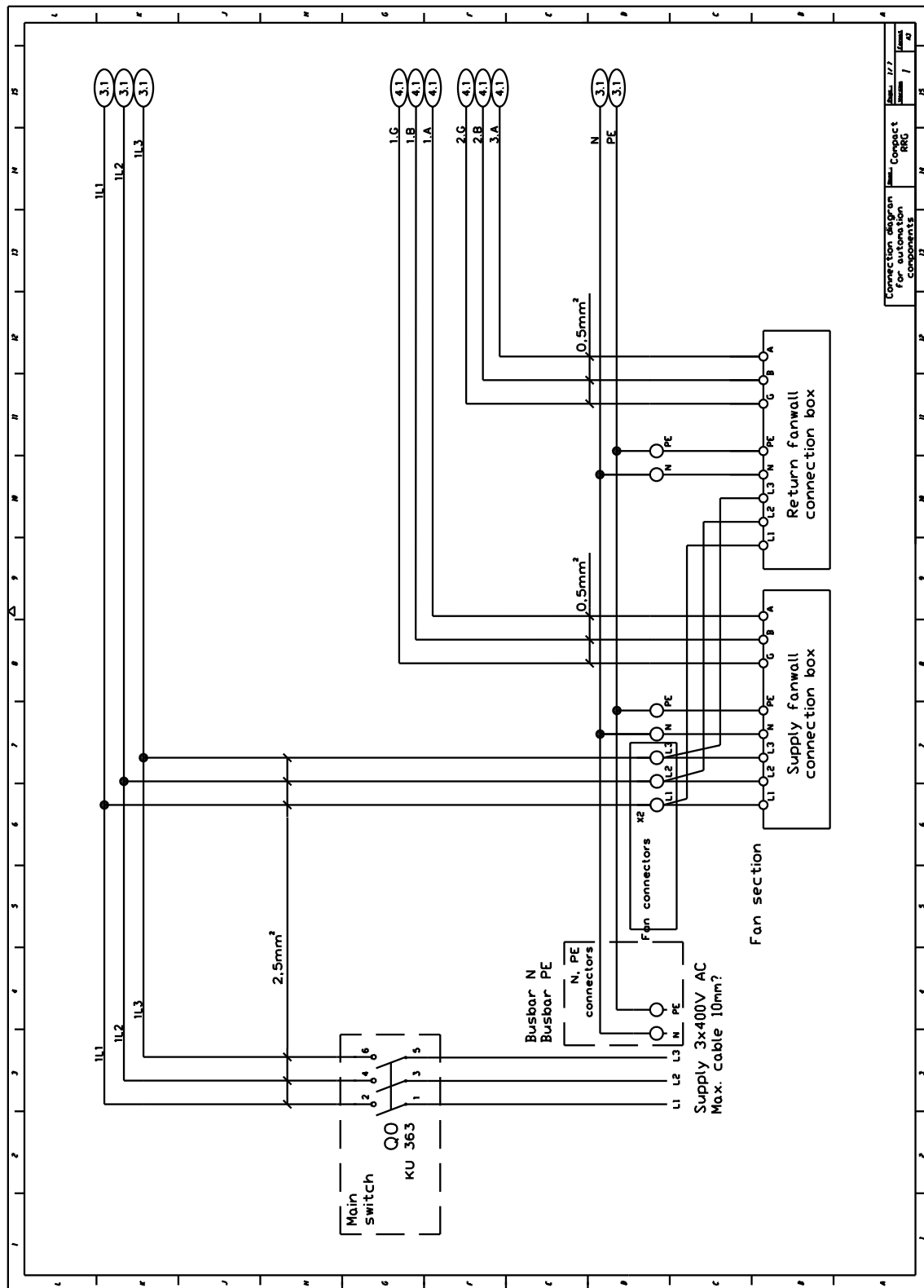

11.3.2 VENTUS COMPACT HP AHU (2/11)

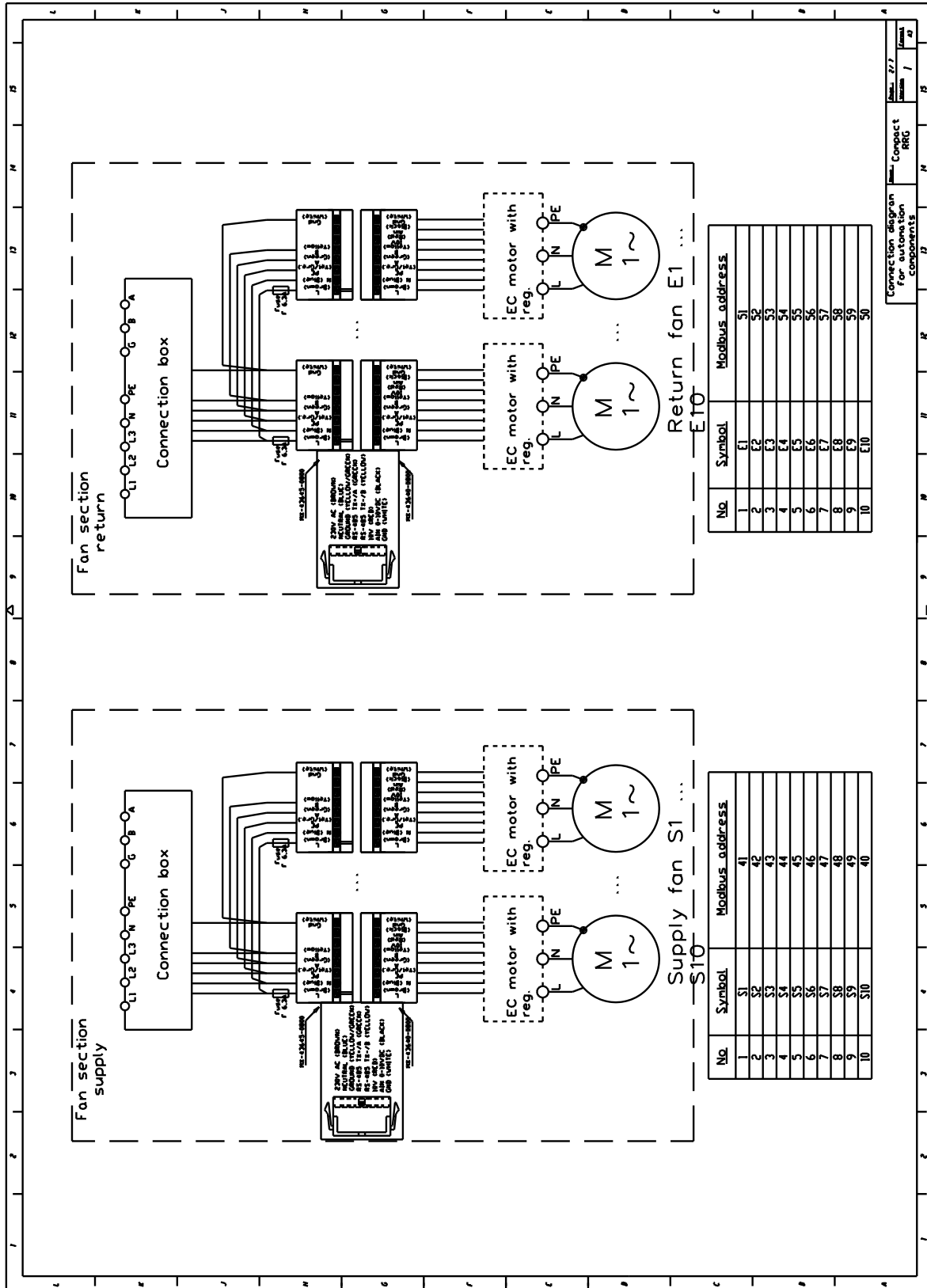

11.3.3 VENTUS COMPACT HP AHU (3/11)

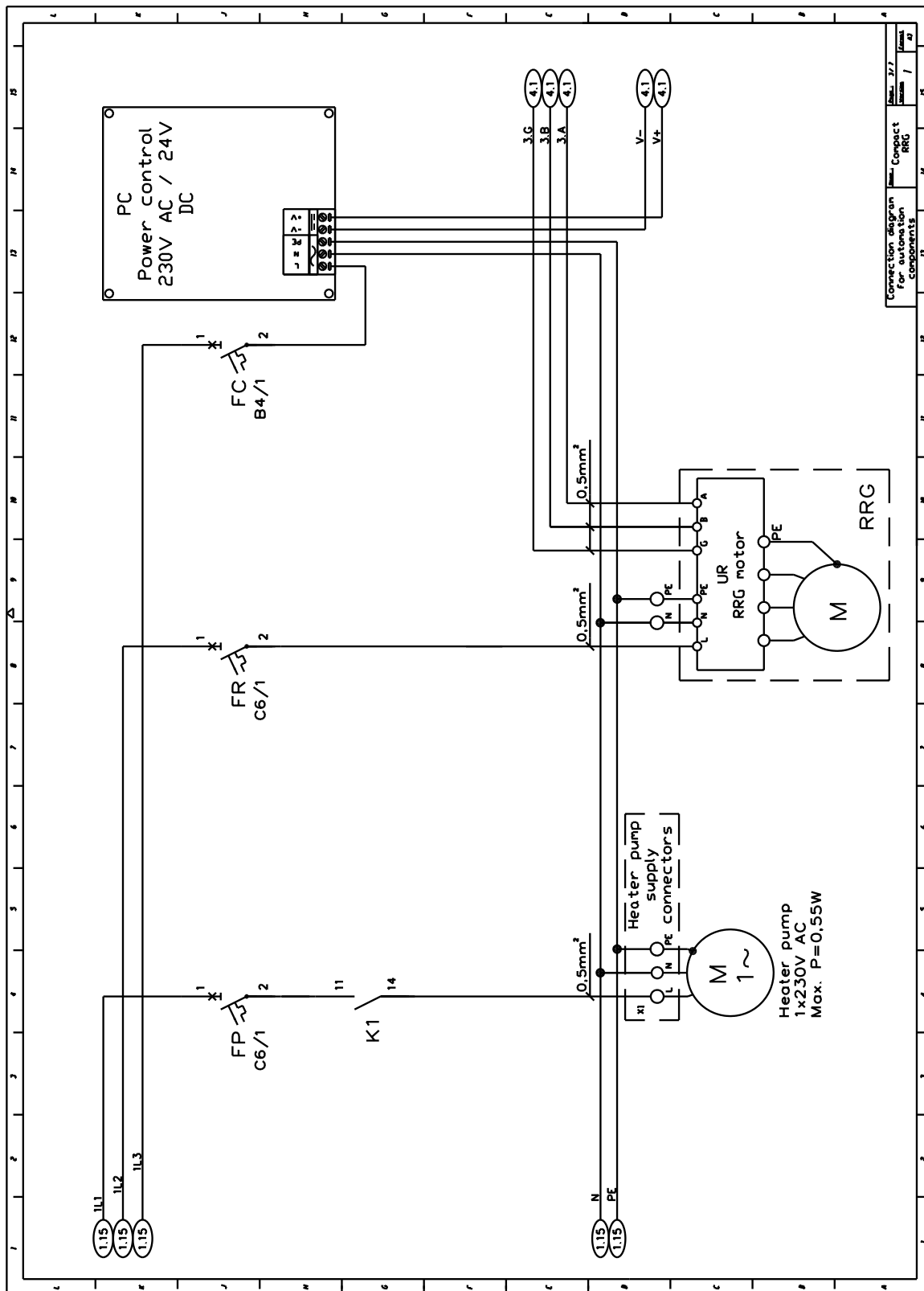

11.3.4 VENTUS COMPACT HP AHU (4/11)

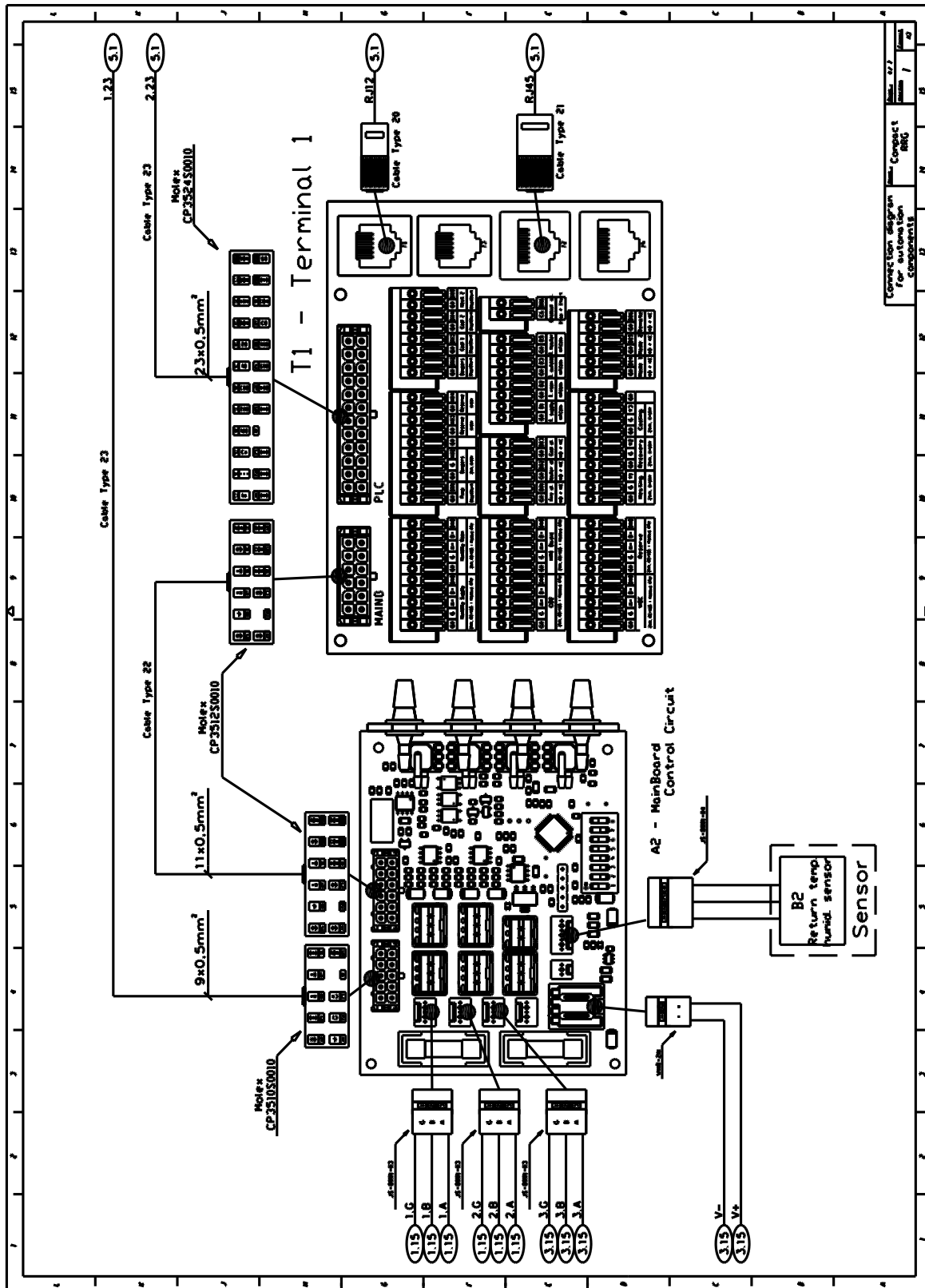

11.3.5 VENTUS COMPACT HP AHU (5/11)

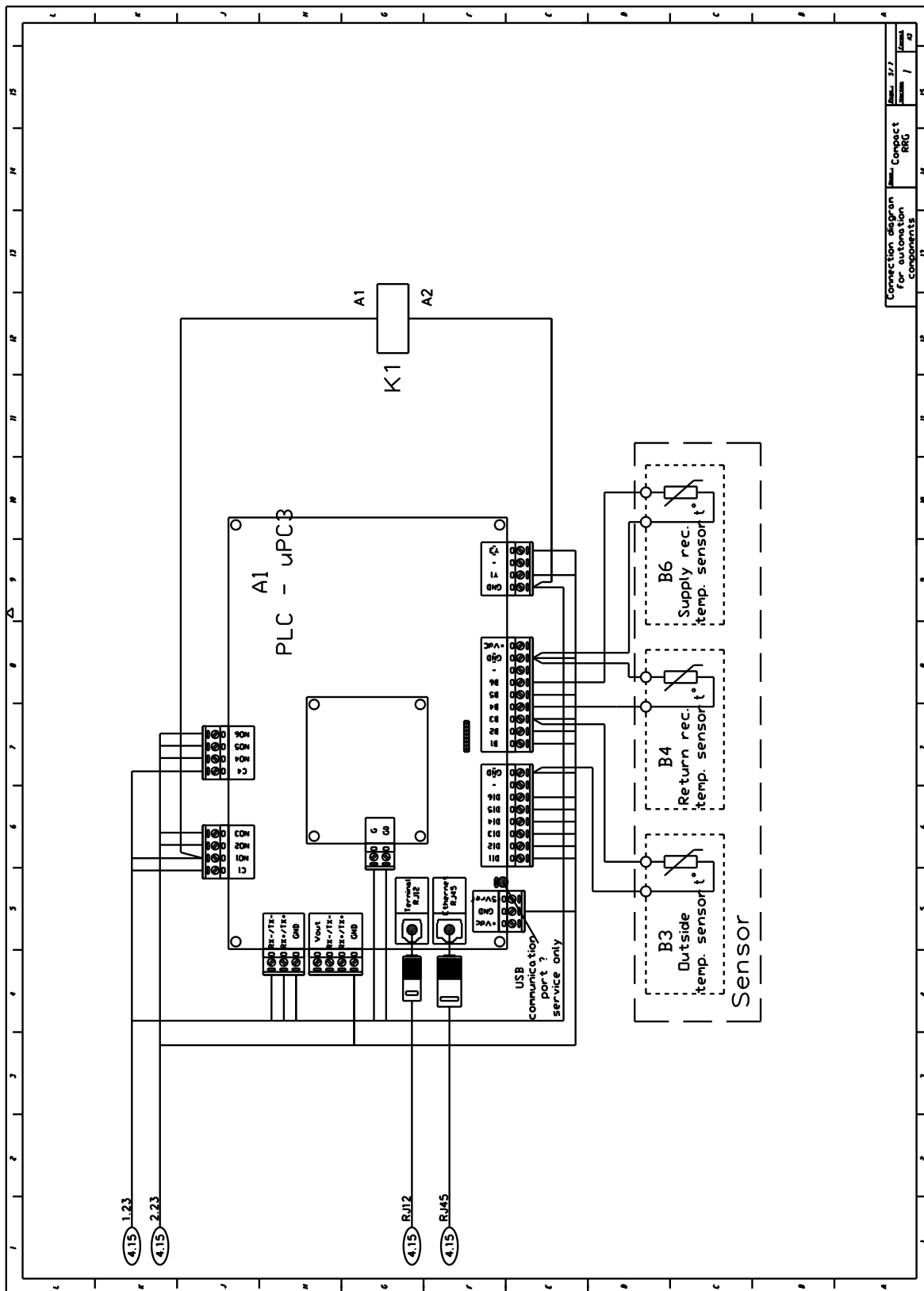

Connection diagram for automation components	
Rev. 3/7	1/20

11.3.6 VENTUS COMPACT HP AHU (6/11)

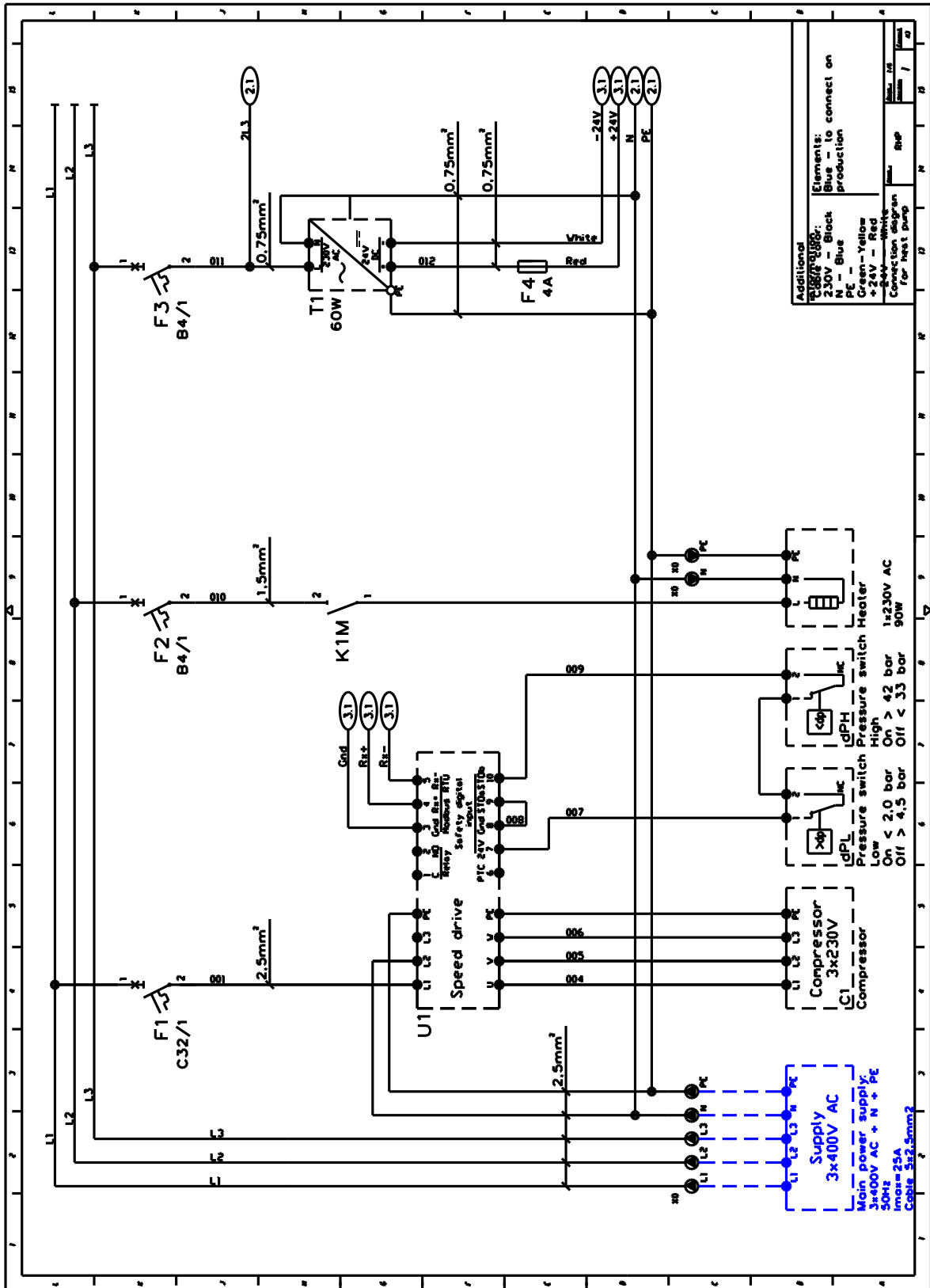

11.3.7 CENTRAL VENTUS COMPACT HP (7/11)

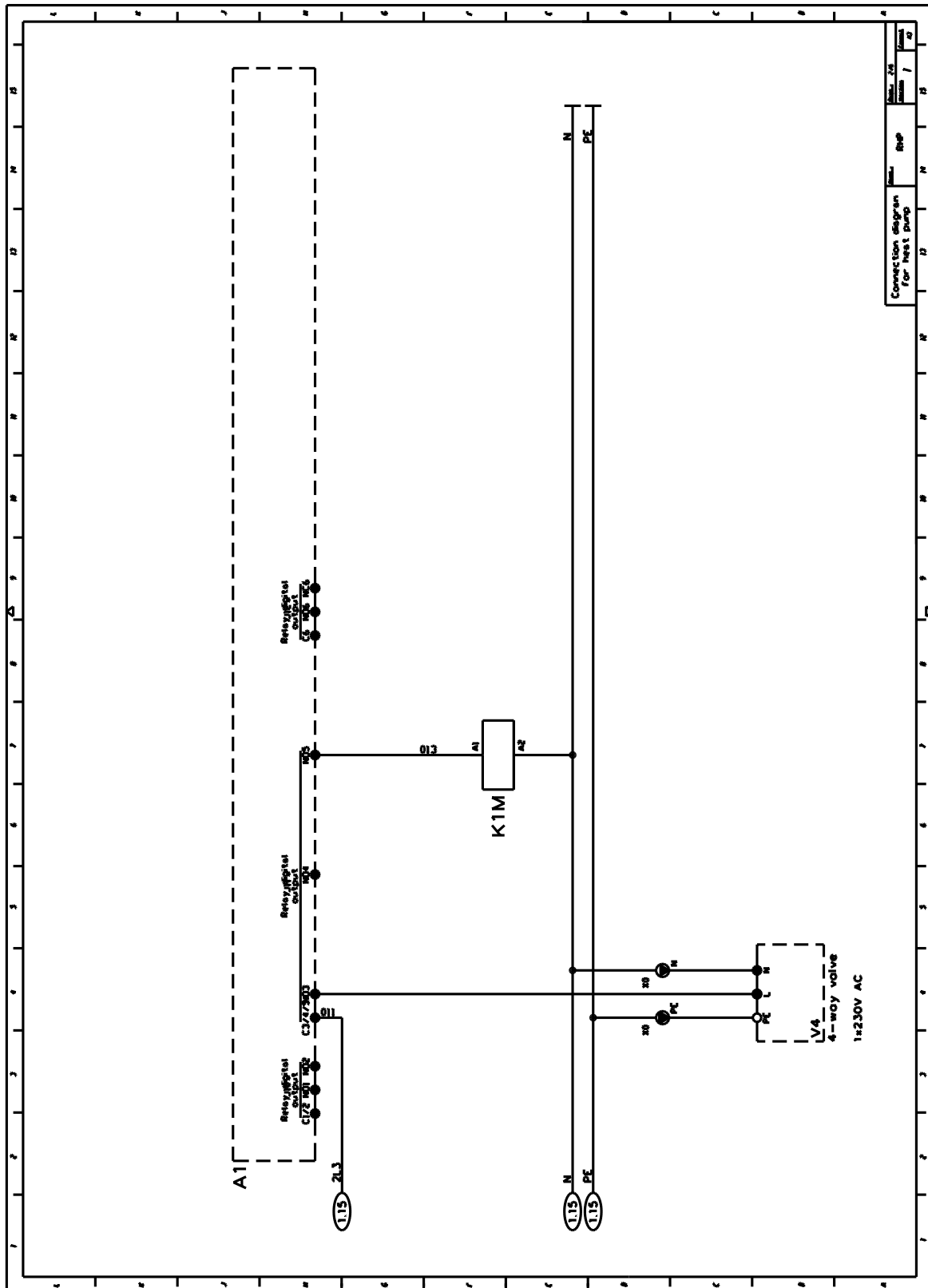

11.3.10 VENTUS COMPACT HP AHU (10/11)

Set of elements

No	Symbol	Name	Specification
1	X0	Cable connectors	3x4mm ²
2	F1	Overcurrent circuit breaker - Compressor	C25/3
3	F2	Overcurrent circuit breaker - Heater	B4/1
4	F3	Overcurrent circuit breaker - Control 230V	B4/1
5	F4	Fuse terminal block - Control 24V	4A
6	K1M	Relay - Heater	230VAC / 8A
7	T1	Power Supply	230V AC / 24V DC 60W
8	A1	Controller c.pLCD Mini	P+D000UEIDLFO
9	UI	BLDC speed drive - Carel Power+ PSDI	PSDI0184A0
10	X0	Busbar	N 6x4mm ² , PE 6x4mm ²
11	X1	Busbar	6x1,5mm ²
12	X2	Busbar	6x1,5mm ²
13	X3	Busbar	6x1,5mm ²

Set of automation elements

No	Symbol	Name	Specification
1	C1	BLDC compressor	-
2	EEV	EEV valve - unipolar connector	Carel E2V
3	V4	4-way valve	230V AC
4	dPH	Pressure switch - high	42 bar
5	dPL	Pressure switch - low	2,5-bar
6	dPE	Pressure transducer - Evaporating	Carel SPK10033P0
7	dPC	Pressure transducer - Condensing	Carel SPK100B6P0
8	Ts	Temperature sensor - Suction	Carel NTC015HF01
9	Td	Temperature sensor - Discharge	Carel NTC015HF01

Automation elements
for heat pump

11.3.11 CENTRAL VENTUS COMPACT HP (11/11)

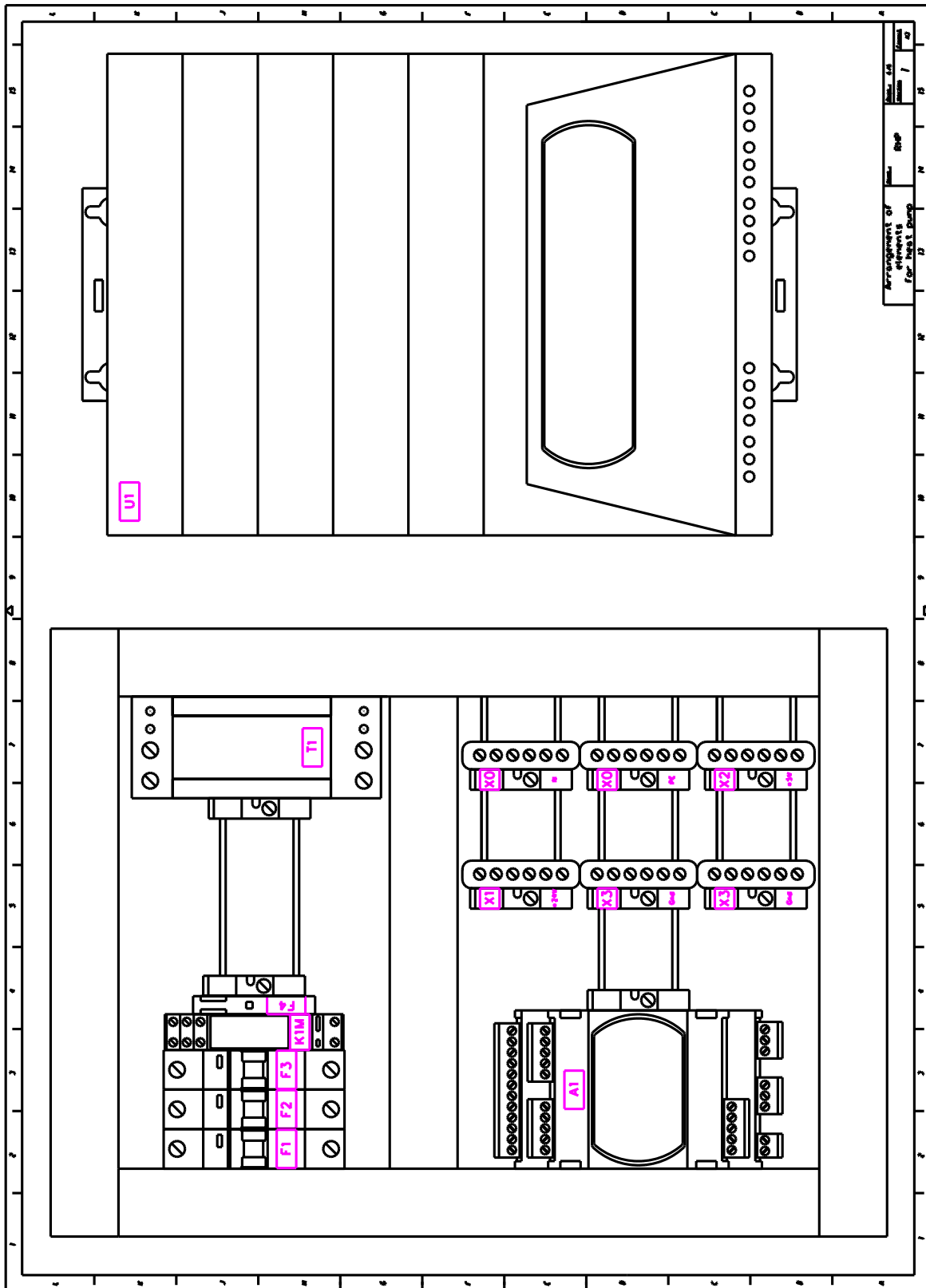

12 ADDITIONAL INFORMATION

12.1 TECHNICAL INFORMATION FOR REGULATION (EU) N327/2011 IMPLEMENTING DIRECTIVE 2009/125/EC

SR-FS FANS							
Fan Set Model	#2	#5	#9-1	#9-2	#9-3	#10	#11
	[%]	[%]	[-]	[kW]	[m³/h].	[Pa]	[rpm]
SR-FS-P-225-0.3	65,40	73,30	SR-FS-P-225-0.3	0,43	1 288	704	3 600
SR-FS-P-225-0.7	62,00	68,10	SR-FS-P-225-0.7	0,85	1 642	1 065	4 500
SR-FS-P-250-0.3	66,20	73,30	SR-FS-P-250-0.3	0,49	1 676	633	3 000
SR-FS-P-250-0.7	67,40	72,40	SR-FS-P-250-0.7	0,98	2 060	1 058	3 800
SR-FS-P-315-0.3	65,40	72,70	SR-FS-P-315-0.3	0,49	2 256	461	2 060
SR-FS-P-315-0.7	66,20	72,00	SR-FS-P-315-0.7	0,75	2 411	674	2 400
SR-FS-P-315-1.5	69,70	73,00	SR-FS-P-315-1.5	1,77	3 560	1 164	3 250
SR-FS-P-315-2.5	67,80	70,40	SR-FS-P-315-2.5	2,44	3 964	1 419	3 600
SR-FS-A-225-0.3	62,70	71,10	SR-FS-A-225-0.3	0,41	1 238	674	3 600
SR-FS-A-225-0.7	59,70	66,20	SR-FS-A-225-0.7	0,83	1 527	1 069	4 500
SR-FS-A-250-0.3	62,40	70,00	SR-FS-A-250-0.3	0,48	1 456	672	3 000
SR-FS-A-250-0.7	65,20	70,60	SR-FS-A-250-0.7	0,93	2 111	950	3 800
SR-FS-A-315-0.3	62,30	70,20	SR-FS-A-315-0.3	0,46	2 119	437	2 060
SR-FS-A-315-0.7	64,40	70,60	SR-FS-A-315-0.7	0,71	2 296	648	2 400
SR-FS-A-315-1.5	67,60	71,30	SR-FS-A-315-1.5	1,69	3 428	1 118	3 250
SR-FS-A-315-2.5	67,10	69,90	SR-FS-A-315-2.5	2,33	3 902	1 363	3 600
SR-FS-A-355-1.6	70,00	73,60	SR-FS-A-355-1.6	1,65	4 017	967	2 650
SR-FS-A-355-2.5	69,90	72,20	SR-FS-A-355-2.5	2,50	4 513	1 316	3 000
SR-FS-A-355-3.7	66,90	68,40	SR-FS-A-355-3.7	3,57	5 199	1 573	3 400
SR-FS-A-400-1.6	70,70	73,70	SR-FS-A-400-1.6	1,89	4 876	920	2 250
SR-FS-A-400-2.5	68,40	71,00	SR-FS-A-400-2.5	2,41	6 366	879	2 000
SR-FS-A-400-3.7	66,70	67,90	SR-FS-A-400-3.7	3,83	5 836	1 499	2 850
SR-FS-A-400-5.4	66,70	66,70	SR-FS-A-400-5.4	5,65	6 802	1 916	3 250
SR-FS-A-450-1.6	70,20	73,60	SR-FS-A-450-1.6	1,75	5 176	798	1 800
SR-FS-A-450-2.5	68,10	71,00	SR-FS-A-450-2.5	2,24	5 068	1 021	2 400
SR-FS-A-450-3.7	67,70	69,20	SR-FS-A-450-3.7	3,57	7 086	1 170	2 300
SR-FS-A-450-5.4	66,80	67,10	SR-FS-A-450-5.4	5,29	8 021	1 526	2 600
SR-FS-A-500-3.7	69,80	71,20	SR-FS-A-500-3.7	3,59	8 577	1 001	1 900
SR-FS-A-500-5.4	70,10	70,50	SR-FS-A-500-5.4	5,06	9 562	1 284	2 130
SR-FS-A-560-3.7	69,00	70,40	SR-FS-A-560-3.7	3,58	9 486	893	1 600
SR-FS-A-560-5.4	69,00	69,00	SR-FS-A-560-5.4	5,52	11 192	1 176	1 830
PARAMETER acc. to (EU) 327/2011	VALUE						
#3	A						
#4	Static						
#6	Year of manufacture printed on the product nameplate.						
#7	Swiss Rotors sp. z o.o. , 586-001-73-79 , Rumska 18, 81-198, Dębogórze, Poland						
#8	YES						
#12	Disposal shall be carried out in a suitable and environmentally friendly manner in accordance with the legal regulations of the country concerned. "Materials are sorted and segregated in an environmentally friendly manner." If necessary, they should be taken to a specialist facility.						
#13	Information provided in the relevant chapters of the dedicated manual, especially on maintenance (www. https://swissrotors.com)						
#14	N/A						

12.2 ASSOCIATED INSTRUCTIONS



- ! Refer to the detailed instructions and make the connections and configurations according to the documentation available at www.vtsgroup.com and the instructions supplied with the equipment. In particular, you should familiarise yourself with:
- Installation, Operation and Maintenance Manual - VENTUS Software - uPC3 control / VTS Ventilation Software for air handling units (Ventus - Application uPC3) uPC3 controller - connection diagram,
 - Installation, Operation and Maintenance Manual VENTUS Heat Wheel Drive / rotary heat exchanger drive manual,
 - Roof assembly / roof installation
 - Installation Manual Sections Connection,
 - Installation, Operation and Maintenance Manual Vts Ec Motor Drive / Technical terms and conditions for drives with EC motors for VTS units,
 - Operation and Maintenance manual - Electric Heaters - Power Slices / Electric Heaters - Slices Technical and Operational Documentation.
 - Others available at www.vtsgroup.com

12.3 DISMANTLING AND DISPOSAL



- ! The dismantling of the appliance should be carried out and/or supervised by suitably qualified personnel with the appropriate level of knowledge and authority. A certified waste disposal organisation in your region should be contacted. Confirm how to prepare and segregate materials, especially hazardous materials that may have been used in the construction of the appliance (e.g. batteries).
- ! Components should be sorted with a view to recycling by material: iron and steel, aluminium, copper, non-ferrous metals e.g. windings (winding insulation will be burned off when copper is recycled), insulating materials, electrical wiring, electronic waste, plastic components, etc. The same applies to fabrics and cleaning substances that have been used during component dismantling. The separation of components should be done according to local regulations or by a specialised recycling firm.
- ! The unit should be dismantled using general procedures commonly used in mechanical engineering, respecting local regulations for disposal and waste management.
- ! Low-moisture (CFC) installations are filled with refrigerant, usually R41A, which cannot escape into the atmosphere. The refrigerant must be recovered in accordance with the regulations in force (this operation must be carried out by a qualified person).

GENERAL DISMANTLING PROCEDURE

- Disconnection of all media.
- Removal of heating and cooling agents from the installation.
- Dismantling of inspection panels.
- Dismantling of electrical and automation systems.
- Removal of all accessories and components from the control unit.
- Dismantling of components according to the material they are made of.
- Dismantling of the casing.
- Separation of insulation from sheet metal.
- Segregation of materials and components according to material.
- Transfer of materials for disposal.



- ! General safety rules must be observed.
- ! In particular, it is important to bear in mind:
 - The weight of the appliance and its components. The appliance consists of heavy components. These parts may fall during disassembly, which may cause death, serious personal injury or material damage.
 - Disconnection of the supply voltage including all associated systems.
 - Prevention of accidental re-engagement.
 - The presence of control or electronic components in which electricity can be stored.

12.4 NOTES

Routine checks, carried out by qualified technical personnel or service personnel authorised by VTS, guarantee long-term, reliable and trouble-free operation of the equipment. Our service personnel is available at all times to provide support for commissioning, maintenance and in the event of any emergency situation relating to the operation of the unit.

VTS authorised service stations sell spare parts and accessories for our air handling units. When ordering parts, please specify the type of air handling unit, size and series number.

More information on the VTS service network can be found at www.vtsgroup.com.



- ! The unit is equipped with mechanisms for automatic remote identification, configuration and data exchange with the manufacturer's external systems. The manufacturer can collect operating and configuration statistics and change the settings of the control and measurement devices responsible for the operation of the equipment.
- ! The aforementioned equipment excludes its use in facilities where the transmission of data outside the facility is prohibited. Such facilities include 'critical infrastructure', which includes, among others, infrastructure of the uniformed services, the Security Agency, the Armed Forces, infrastructure created or upgraded as part of international defence and security cooperation.
- ! The above-mentioned remote communication mechanisms may be used in data-sensitive facilities, provided that the administrator of such infrastructure is effectively informed. Sensitive facilities are infrastructure:
 - Revenue Administration Services.
 - Critical Infrastructure Projects:
 - Energy: (transmission and distribution network operators, power plants, transformer stations).
 - Telecommunications: (telecommunications network operators, internet service providers).
 - Transport: (railways, airports, seaports, public transport operators).
- ! It is possible to order equipment without mechanisms for automatic remote identification, configuration and data exchange with the manufacturer's external systems.



The unit's rating plate includes the sound pressure level LWA (1m) quoted for a distance of 1m from the unit.

To calculate the LWA values at 3m and 5m, use the formula:

- $LWA(3m) = LWA(1m) - 9.54$
- $LWA(5m) = LWA(1m) - 13.98$



Original version of instructions in Polish. Other language versions are machine translated.
VTS reserves the right to make changes without notice

12.5 EU DECLARATION OF CONFORMITY

DEKLARACJA ZGODNOŚCI UE / EU DECLARATION OF CONFORMITY

My Producent:
The Manufacturer:

VTS Sp. z o.o.
ul. Aleja Grunwaldzka 472A
80-309 Gdańsk, Poland



Strona internetowa:
Website:

www.vtsgroup.com

Deklarujemy z pełną odpowiedzialnością, że wyroby:
We hereby declare that the following products:

Centrala wentylacyjna: Ventus
Air handling unit: Ventus

Modele / Models:

Rok produkcji: / Year of manufacture:

Numer seryjny: / Serial number:

Wyrób jest zgodny w całości z postanowieniami następujących dyrektyw oraz z następującymi normami oraz standardami:
The product complies with the provisions of the following directives and with the following norms, standards, internal report:

DYREKTYWY / DIRECTIVES

2006/42/WE Dyrektywa maszynowa
2006/42/EC Machinery Directive

2009/125/WE Dyrektywa Ekoprojektu
2009/125/EC Ecodesign Directive

2014/30/UE Dyrektywa kompatybilności
elektromagnetycznej 2014/30 / EU EMC Directive

2011/65/UE, 2015/863/UE Dyrektywa RoHS
2011/65/EU, 2015/863/EU RoHS Directive

2014/35/UE Dyrektywa niskonapięciowa
2014/35/EU Low Voltage Directive

STANDARDY I SPECYFIKACJE / STANDARDS AND SPECIFICATIONS

EN ISO 12100:2010 | EN ISO 13857:2019 | EN 60204-1:2018 | EN 60335-1:2012 | EN 60335-2-40:2024 | EN 50106:2008 | EN 60529::1991+A1:2000+A2:2013

327/2011 | 1253/2014 | EN 13053:2019

EN 62233:2008 | EN 61000-6-2:2019 | EN 61000-6-3:2021

EN IEC 63000:2018

Zastosowana procedura oceny zgodności: Moduł A2 w zakresie dyrektywy ciśnieniowej, nr certyfikatu:

The conformity assessment procedure: Module A2 of the Pressure Equipment Directive, certification no.:

103736/JN/001/04

Jednostka notyfikowana: Notified body No:	Urząd Dozoru Technicznego Nr 1433 UDT, ul. Szczęśliwicka 34, 02-353 Warszawa, Polska.	
Model zespołu ciśnieniowego Type of pressure equipment	VVS040c HP x 6; VVS055c HP x 6; VVS075c HP x 6	
	Kategoria zagrożenia PED PED hazard category	Moduł oceny zgodności Conformity assessment procedure module
Sprężarka / Compressor	kategoria I / category I	Art. 1.2
Zbiornik / Liquid receiver	kategoria II / category II	A
Zawór bezpieczeństwa / Safety Valves	kategoria IV / Category IV	H1
Kompletne urządzenie ciśnieniowe / Assembled pressure device	kategoria II / category II	A2

Pozostałe elementy układu ciśnieniowego są zgodne z Art. 4.3 dyrektywy ciśnieniowej. Wykaz elementów z których składa się zespół ciśnieniowy znajduje się w Instrukcji Użytkownika (Dokumentacji Techniczno-Ruchowej) urządzenia.
The remaining elements of the pressure system comply with Article 4.3 of the Pressure Equipment Directive. The list of components of the pressure assembly can be found in the User Manual (Operation and Maintenance Manual) of the device.