



EN

User's Manual (Installation, Operation and Maintenance Manual)

Floor mounted Air Handling Units

VENTUS VVS007-VVS650

CE

VENTUS

IOMM VENTUS - ver. 6.0.7 (06.2026)

CONTENT

Content	
1	HEALTH AND SAFETY INSTRUCTIONS 5
2	GENERAL INFORMATION 12
3	TRANSPORTATION AND STORAGE 19
4	INSTALLATION OF THE DEVICE 24
4.1	LOCATION OF THE DEVICE (PLACE OF FOUNDATION) 24
4.1.1	REQUIREMENTS FOR THE DEVICE TO BE INSTALLED ON THE SITE - DELIVERY IN PACKAGES..... 25
4.1.2	REQUIREMENTS FOR THE DEVICE TO BE INSTALLED ON THE SITE - DELIVERY IN SECTIONS28
4.2	FOUNDATION OF THE DEVICE OF <i>VENTUS</i> AHU..... 28
4.2.1	HV FRAME..... 31
4.2.2	"C" SHAPE BASE FRAME 34
4.3	CONNECTING AIR DUCTS..... 39
4.4	CONNECTING SECTIONS VVS021-VVS150 40
4.5	CONNECTING VVS180-VVS650 SECTIONS 45
4.6	ROOF ASSEMBLY..... 53
4.7	INSTALLATION OF THE AIR DAMPER ACTUATOR COVER 55
5	CONNECTION OF RELATED INSTALLATIONS..... 56
5.1	CONNECTION OF WATER HEATERS AND COOLERS 56
5.2	CONNECTION OF DX (DIRECT EXPANSION) EXCHANGERS 60
5.3	CONDENSATE DRAINAGE 61
5.4	CONNECTION OF EVAPORATIVE HUMIDIFIER..... 63
6	POWER AND CONTROL INSTALLATIONS 66
6.1	FAN ELECTRIC MOTOR..... 67
6.1.1	AHU UNITS WITH EC MOTOR 67
6.1.2	AIR HANDLING UNITS WITH AC MOTOR OF 0.75KW AND ABOVE..... 68
6.2	ELECTRIC HEATER 71
6.2.1	THERMAL SWITCH (THERMIC)..... 73
6.2.2	DIFFERENTIAL PRESSURE SWITCH 74
6.2.3	CONNECTION OF AUTOMATION OF ELECTRIC HEATERS..... 75
6.3	ROTARY HEAT EXCHANGER (REGENERATIVE HEAT EXCHANGER) 76
6.4	EVAPORATIVE HUMIDIFIER 77
6.5	CONTROL SYSTEM 81
6.6	AIR DAMPERS 84



7	FIRST START-UP	85
7.1	PREPARING FOR THE FIRST START-UP	85
7.1.1	CHECK THE CONDITION OF THE INSTALLATION	85
7.1.2	CONFIGURATION OF PARAMETERS AND FUNCTIONS.....	92
7.1.3	CONFIGURATION OF DX AND DX-H (REVERSIBLE) EXCHANGERS.....	92
7.1.4	POWER CONFIGURATION OF OPTIONAL ELECTRIC HEATERS	94
7.2	AHU COMMISSIONING	96
7.2.1	AHU STARTUP	96
7.2.2	MEASUREMENT OF AIR VOLUME FLOW AND CONTROL OF AIR HANDLING UNIT EFFICIENCY.....	97
7.2.3	STARTUP INTERFACE SELECTION	99
7.2.4	HMI ADVANCED INTERFACE	100
7.2.5	HMI BASIC 2HY	102
7.2.6	BLUETOOTH MODULE AND mHMI APPLICATION.....	107
7.2.7	OPERATING MODES OF THE CONTROL PANEL.....	119
7.2.8	BASIC PARAMETER CONFIGURATION.....	120
7.2.9	BASIC VERIFICATION OF OPERATION DURING INITIAL START-UP	122
7.3	REGULATION.....	125
7.3.1	HEATING CONTROL OF THE WATER HEATER	125
7.3.2	ADJUSTMENT OF THE ELECTRIC HEATER.....	125
7.3.3	CAPACITY CONTROL OF THE COOLER.....	126
7.3.4	CONTROL OF THE EVAPORATIVE HUMIDIFIER (WITH ADIABATIC EVAPORATION)	126
7.4	THE MOST COMMON ADAPTIVE CHANGES OF PARAMETERS TO THE NEEDS OF THE FACILITY 126	
8	MAINTENANCE AND INSPECTION	130
8.1.1	MULTI-BLADE AIR DAMPERS	130
8.1.2	AIR FILTERS	130
8.1.3	WATER AND GLYCOL HEATER.....	131
8.1.4	WATER AND GLYCOL COOLER	132
8.1.5	ELECTRIC HEATER	133
8.1.6	DX (FREON) HEATERS AND COOLERS	133
8.1.7	EVAPORATIVE HUMIDIFIER	133
8.1.8	HEAT RECUPERATOR (COUNTERFLOW, HEXAGONAL, CROSSFLOW).....	135
8.1.9	ROTARY EXCHANGER.....	137
8.1.10	SOUND ATTENUATORS (DAMPING SPHERES)	138
8.1.11	FAN UNIT	139

8.1.12	FAN SETS.....	139
8.1.13	FAN BEARINGS (AC).....	141
8.1.14	MOTORS (AC).....	143
8.1.15	MOTOR BEARINGS.....	144
8.1.16	BELT TRANSMISSION	146
8.1.17	CONTROL MEASUREMENTS	149
8.2	CONSUMABLES AND SPARE PARTS	150
8.2.1	AIR FILTERS	150
8.2.2	DX 5/16" EXCHANGERS	153
8.2.3	3/8" WCL (WATER) EXCHANGERS VVS021-VVS150	160
8.2.4	1/2" WCL (WATER) EXCHANGERS VVS180-VVS650	163
9	ADDITIONAL INFORMATION.....	165
9.1	TECHNICAL INFORMATION TO REGULATION (EU) 327/2011, IMPLEMENTING DIRECTIVE 2009/125/EC.....	165
9.2	RELATED USER MANUALS.....	170
9.3	DISMANTLING AND DISPOSAL OF	171
9.4	NOTES.....	172
9.5	EU DECLARATION OF CONFORMITY.....	173
10	APPENDIX A - UNIT VVS007.....	174
10.1	DIMENSIONS VVS007	175
10.2	AIR FILTERS	178
10.3	WATER EXCHANGERS	179
10.4	DX EXCHANGERS.....	180
10.5	ROTARY EXCHANGER.....	181

1 HEALTH AND SAFETY INSTRUCTIONS

Thorough familiarisation with the contents of this manual, as well as installation, commissioning and operation of the air handling unit in accordance with the instructions provided and in compliance with all applicable occupational health and safety regulations, will provide a sound basis for efficient, safe and trouble-free operation of the unit.

This document does not cover all possible configurations of these units, does not provide all examples of their assembly and installation, nor does it discuss all aspects of their commissioning, operation, repair and maintenance. If the units are used in accordance with their intended design purpose, both this documentation and any other materials dedicated to the supplied unit contain information intended exclusively for qualified technical personnel.

	WARNING	This symbol is displayed to indicate issues and operations that may involve a risk. Carefully read the section marked with this symbol and follow the instructions
	DANGER	Indicates that failure to follow the instructions may result in minor injury or damage to the product.
		Indicates that failure to follow the instructions may result in serious injury or death.

RECOMMENDATIONS REGARDING THE MANUAL

- Failure to follow the recommendations contained in this manual may result in property damage and personal injury. The manufacturer shall not be held liable for any damage that may result, directly or indirectly, from failure to observe these instructions.
- Depending on the configuration used, the unit may be supplied with additional manuals for the delivered components. It is strongly recommended to read and observe the safety requirements contained in those manuals.
- This manual and the air handling unit documentation, as well as any additional manuals for the components used, if available, must be carefully stored in a place that is easily accessible to operating and service personnel.



WARNING

INSTALLATION, SERVICE WORK AND USE

- ! BEFORE CARRYING OUT ANY WORK, DISCONNECT THE POWER SUPPLY AND SECURE IT AGAINST UNCONTROLLED START-UP OF THE AIR HANDLING UNIT. THE SERVICE WORK IN PROGRESS MUST BE COMMUNICATED AND CLEARLY MARKED.
- ! PERSONAL PROTECTIVE EQUIPMENT (PPE) MUST BE USED DURING WORK.
- ! IN PARTICULAR:
 - o CUT-RESISTANT GLOVES (EN 388) TO PROTECT HANDS AGAINST SHARP EDGES,
 - o SAFETY HELMET (EN 397) WHEN INSTALLING ABOVE HEAD HEIGHT, PROTECTIVE MASK TO PREVENT DUST AND DIRT PARTICLES FROM ENTERING THE LUNGS,
 - o SAFETY GOGGLES AND ANY OTHER PPE REQUIRED BY APPLICABLE REGULATIONS.
- ! ALL SERVICE ACTIVITIES MUST BE CARRIED OUT WITH THE UTMOST CARE.
- ! INSTALLATION, COMMISSIONING AND SERVICING OF AIR HANDLING UNITS AND THEIR EQUIPMENT MAY INVOLVE CERTAIN SAFETY HAZARDS AND THEREFORE REQUIRE SPECIFIC KNOWLEDGE AND TRAINING.
- ! INSTALLATION, COMMISSIONING AND OPERATION OF THE UNIT MUST BE CARRIED OUT BY A PERSON HOLDING THE APPROPRIATE QUALIFICATIONS REQUIRED BY APPLICABLE REGULATIONS.
- ! IT IS RECOMMENDED THAT INSTALLATION, COMMISSIONING, POST-WARRANTY REPAIRS, TECHNICAL INSPECTIONS AND MAINTENANCE WORK REQUIRED FOR AIR HANDLING UNITS BE CARRIED OUT BY A VTS-AUTHORIZED SERVICE PROVIDER.
- ! UNITS THAT ARE INCORRECTLY INSTALLED, ADJUSTED OR REPAIRED BY A PERSON WITHOUT THE REQUIRED QUALIFICATIONS MAY CAUSE SERIOUS PERSONAL INJURY OR EVEN DEATH. THE ABOVE RELEASES THE MANUFACTURER FROM LIABILITY AND FROM ANY OBLIGATIONS UNDER THE WARRANTY AND STATUTORY WARRANTY.
- ! THIS UNIT IS NOT INTENDED FOR USE BY PERSONS, INCLUDING CHILDREN, WITH REDUCED PHYSICAL, SENSORY OR MENTAL CAPABILITIES, OR WITHOUT EXPERIENCE AND KNOWLEDGE, UNLESS THEY ARE SUPERVISED OR HAVE BEEN INSTRUCTED IN THE USE OF THE UNIT BY A PERSON RESPONSIBLE FOR THEIR SAFETY.
- ! CHILDREN MUST BE SUPERVISED TO ENSURE THAT THEY DO NOT PLAY WITH THE UNIT.
- ! CLEANING AND USER MAINTENANCE MUST NOT BE CARRIED OUT BY CHILDREN WITHOUT SUPERVISION.
- ! THE UNIT MUST BE USED IN ACCORDANCE WITH ITS INTENDED PURPOSE AND WITHIN THE OPERATING PARAMETERS FOR WHICH IT HAS BEEN DESIGNED. IN THE EVENT OF IMPROPER USE, THE MANUFACTURER SHALL NOT BE HELD LIABLE FOR ANY RESULTING CONSEQUENCES.



DANGER

ELECTRICAL INSTALLATIONS

- ! ALL ELECTRICAL WORK MUST BE CARRIED OUT BY A LICENSED ELECTRICIAN HOLDING AT LEAST AN E1 QUALIFICATION CERTIFICATE FOR THE OPERATION OF EQUIPMENT, INSTALLATIONS AND NETWORKS, AND A D1 QUALIFICATION CERTIFICATE FOR THE SUPERVISION OF EQUIPMENT, INSTALLATIONS AND NETWORKS.
- ! IF THE UNIT IS EQUIPPED WITH COMPONENTS OR CONNECTED TO INSTALLATIONS THAT REQUIRE E2 AND D2 QUALIFICATIONS, THE INSTALLER AND THE TECHNICAL SUPERVISOR MUST HOLD SUCH QUALIFICATIONS.
- ! CONNECTIONS MUST BE MADE IN ACCORDANCE WITH THE GUIDELINES PROVIDED IN THIS DOCUMENT.
- ! MAKE SURE THAT THE MAINS SUPPLY VOLTAGE COMPLIES WITH THE INFORMATION PROVIDED ON THE RATING PLATES OF THE ELECTRICAL DEVICES. THE PERMISSIBLE DEVIATIONS ARE:
 - SUPPLY VOLTAGE: +/- 5%
 - FREQUENCY: +/- 2%
- ! IT IS ALSO RECOMMENDED TO CHECK THAT ALL EARTHING CONDUCTORS ARE PROPERLY SECURED.
- ! A DEDICATED CIRCUIT AND A MAIN SWITCH WITH A LOCKING DEVICE MUST BE INSTALLED. BEFORE STARTING ANY SERVICE OR MAINTENANCE WORK, SET THE MAIN DISCONNECT SWITCH TO THE OFF POSITION.
- ! INCORRECT WIRING OR INSTALLATION MAY CAUSE FIRE OR ELECTRIC SHOCK.
- ! DO NOT USE A DAMAGED OR INCORRECTLY SELECTED SWITCH OR CABLE.



WARNING

CAUTION! HOT PARTS

- ! THE UNIT CONTAINS COMPONENTS WHOSE SURFACE TEMPERATURE MAY BE HIGH, SUCH AS HEAT EXCHANGERS, HEATERS OR THE MOTOR HOUSING. DIRECT CONTACT WITH THESE PARTS MAY RESULT IN BURNS OR OTHER INJURIES. SPECIAL CARE MUST BE TAKEN, APPROPRIATE PROTECTIVE CLOTHING MUST BE WORN, AND SERVICE WORK MAY ONLY BE STARTED ONCE THEIR TEMPERATURE HAS FALLEN BELOW 40°C.

CAUTION! SHARP EDGES

- ! THE UNIT CONTAINS SHARP EDGES, FOR EXAMPLE HEAT EXCHANGER FINS. CONTACT WITH THEM MAY RESULT IN CUTS. THEREFORE, SPECIAL CARE MUST BE TAKEN AND PROTECTIVE CLOTHING MUST BE WORN.

CAUTION! MOVING PARTS

- ! THE UNIT CONTAINS MOVING PARTS, SUCH AS FAN IMPELLERS. CONTACT WITH THEM MAY RESULT IN CUTS OR SERIOUS INJURY. SERVICE WORK MAY ONLY BE STARTED AFTER THESE PARTS HAVE COME TO A COMPLETE STOP.
- ! OPENING INSPECTION PANELS WHILE THE AIR HANDLING UNIT IS OPERATING, OR STARTING THE UNIT WITH INSPECTION PANELS OPEN, IS STRICTLY PROHIBITED.
- ! BEFORE OPENING THE INSPECTION PANELS SWITCH OFF THE AIR HANDLING UNIT AND WAIT FOUR MINUTES FOR ALL MOVING PARTS TO COME TO A COMPLETE STOP.



WARNING

RESIDUAL RISK

DURING THE DESIGN AND MANUFACTURING PROCESS OF THE UNITS, THE RISK TO PEOPLE AND PROPERTY HAS BEEN MINIMISED. NEVERTHELESS, A CERTAIN LEVEL OF RISK MAY STILL OCCUR WHICH IS BEYOND THE MANUFACTURER'S CONTROL:

- **HAZARDS RESULTING FROM INCORRECT INSTALLATION AND ASSEMBLY:**
 - INSTALLATION IN LOCATIONS ACCESSIBLE TO UNAUTHORISED PERSONS, WHICH MAY CREATE A RISK TO HEALTH AND LIFE.
 - INSTALLATION IN LOCATIONS WHERE SERVICE WORK IS DIFFICULT OR DANGEROUS TO HEALTH OR LIFE.
 - ACCUMULATION AND LEAKAGE OF CONDENSATE, WHICH MAY LEAD TO PROPERTY DAMAGE, ELECTRICAL SHORT CIRCUITS OR SLIPPERY SURFACES.
 - LEAKAGE OF REFRIGERANT OR HEATING MEDIUM FROM THE CIRCUIT, CREATING A RISK TO HEALTH AND LIFE AND CAUSING PROPERTY DAMAGE.
 - FALLING OF A UNIT INSTALLED ON AN UNSUITABLE SUPPORT STRUCTURE, CREATING A RISK TO HEALTH AND LIFE AND CAUSING PROPERTY DAMAGE.
- **HAZARDS RESULTING FROM INCORRECT TRANSPORT:**
 - FALLING OR TIPPING OVER OF THE TRANSPORTED UNIT OR ITS COMPONENTS, CREATING A RISK TO HEALTH AND LIFE AS WELL AS TO PROPERTY.
- **HAZARDS RESULTING FROM INCORRECT STORAGE:**
 - STORAGE UNDER CONDITIONS THAT MAY LEAD TO DAMAGE, DEFORMATION OR CHANGES IN THE PROPERTIES OF THE UNIT OR ITS COMPONENTS, AS A RESULT OF WHICH THE UNIT MAY OPERATE INCORRECTLY OR FAIL TO MEET THE DECLARED REQUIREMENTS.
- **HAZARDS RESULTING FROM INCORRECT ELECTRICAL INSTALLATION:**
 - SHORT CIRCUITS, FIRES AND THE RELEASE OF TOXIC FUMES, WHICH CONSTITUTE A REAL RISK TO HEALTH AND LIFE AND MAY LEAD TO PROPERTY DAMAGE.
 - OPERATION OF THE UNIT WITHOUT FITTED PANELS AND PROTECTIVE GUARDS:
 - CONTACT WITH MOVING OR HOT PARTS MAY CREATE A RISK TO HEALTH AND LIFE.



WARNING

FAULTS, REPAIRS, MODIFICATIONS

- ! IF A FAULT OR INCORRECT OPERATION OF THE UNIT IS DETECTED, THE UNIT MUST BE SWITCHED OFF IMMEDIATELY AND AN AUTHORISED SERVICE PROVIDER MUST BE CONTACTED.
- ! ALL REPAIRS MUST BE CARRIED OUT BY THE MANUFACTURER'S AUTHORISED SERVICE PROVIDER, USING ORIGINAL SPARE PARTS.
- ! ROUTINE INSPECTIONS CARRIED OUT BY QUALIFIED TECHNICAL PERSONNEL OR BY A VTS-AUTHORISED SERVICE PROVIDER ENSURE LONG-TERM, RELIABLE AND TROUBLE-FREE OPERATION OF THE UNITS. OUR SERVICE PERSONNEL ARE AVAILABLE AT ALL TIMES TO PROVIDE SUPPORT DURING COMMISSIONING, MAINTENANCE AND IN THE EVENT OF ANY EMERGENCY SITUATIONS RELATED TO THE OPERATION OF THE UNIT.
- ! VTS-AUTHORISED SERVICE STATIONS SELL SPARE PARTS AND ACCESSORIES FOR OUR AIR HANDLING UNITS. WHEN ORDERING PARTS, PLEASE PROVIDE THE AIR HANDLING UNIT TYPE, SIZE AND SERIAL NUMBER.



INFORMATION FOR USERS ON THE PROPER HANDLING OF WASTE ELECTRICAL AND ELECTRONIC EQUIPMENT (WEEE).

WITH REFERENCE TO EUROPEAN UNION DIRECTIVE 2002/96/EC OF 27 JANUARY 2003 AND THE RELATED NATIONAL REGULATIONS, PLEASE NOTE THAT:

- ! WASTE ELECTRICAL AND ELECTRONIC EQUIPMENT (WEEE) MUST NOT BE DISPOSED OF AS MUNICIPAL WASTE. SUCH WASTE MUST BE COLLECTED AND DISPOSED OF SEPARATELY.
- ! PUBLIC OR PRIVATE WASTE COLLECTION SYSTEMS SPECIFIED IN LOCAL REGULATIONS MUST BE USED.
- ! THE EQUIPMENT MAY CONTAIN HAZARDOUS SUBSTANCES. IMPROPER USE OR INCORRECT DISPOSAL OF SUCH SUBSTANCES MAY HAVE A NEGATIVE IMPACT ON HUMAN HEALTH AND THE ENVIRONMENT.
- ! THE SYMBOL OF THE CROSSED-OUT WHEELED BIN, PLACED ON THE PRODUCT, PACKAGING OR TECHNICAL LEAFLET, MEANS THAT THE EQUIPMENT WAS PLACED ON THE MARKET AFTER 13 AUGUST 2005 AND MUST BE DISPOSED OF SEPARATELY.
- ! BY SORTING AND HANDING OVER WASTE ELECTRICAL AND ELECTRONIC EQUIPMENT FOR PROCESSING, RECOVERY, RECYCLING AND DISPOSAL, YOU PROTECT THE ENVIRONMENT AGAINST POLLUTION AND CONTAMINATION, HELP REDUCE THE USE OF NATURAL RESOURCES AND LOWER THE COST OF MANUFACTURING NEW EQUIPMENT.
- ! IN THE EVENT OF ILLEGAL DISPOSAL OF ELECTRICAL AND ELECTRONIC WASTE, PENALTIES ARE SPECIFIED IN LOCAL WASTE DISPOSAL REGULATIONS.



DANGER



EMERGENCY SITUATIONS – FIRE

PROCEDURE IN THE EVENT OF A FIRE INVOLVING ELECTRICAL EQUIPMENT:

KEEP CALM - DO NOT PANIC, ASSESS THE SITUATION.

DISCONNECT THE POWER SUPPLY:

- IF POSSIBLE, CUT OFF THE POWER SUPPLY, E.G. BY SWITCHING OFF THE FUSES OR THE MAIN SWITCH.
- DO NOT TOUCH THE UNIT OR CABLES WITH BARE HANDS, AS THEY MAY STILL BE LIVE.

CALL FOR HELP:

- CALL THE EMERGENCY NUMBER.
- PROVIDE THE EXACT ADDRESS AND A BRIEF DESCRIPTION OF THE SITUATION.

EXTINGUISHING THE FIRE:

DO NOT USE WATER! WATER CONDUCTS ELECTRICITY AND MAY CAUSE ELECTRIC SHOCK.

- USE SUITABLE FIRE-FIGHTING EQUIPMENT:
 - CO₂ FIRE EXTINGUISHER, CARBON DIOXIDE, RECOMMENDED FOR EXTINGUISHING LIVE ELECTRICAL EQUIPMENT.
 - ABC POWDER FIRE EXTINGUISHER, MAY BE USED, BUT MAY DAMAGE ELECTRONIC COMPONENTS.

EVACUATION:

- IF THE FIRE IS SERIOUS OR CANNOT BE EXTINGUISHED SAFELY, LEAVE THE ROOM AND CLOSE THE DOOR BEHIND YOU TO LIMIT THE OXYGEN SUPPLY.
- HELP OTHERS LEAVE THE BUILDING.
- DO NOT USE LIFTS.

IN THE EVENT OF A FIRE, there is a risk to health and life due to high temperature, heavy smoke and the release of harmful gases, including carbon monoxide, carbon dioxide, hydrogen chloride, hydrogen cyanide and dioxins.

! THE USE OF RESPIRATORY PROTECTIVE EQUIPMENT (RPE) IS REQUIRED!

2 GENERAL INFORMATION

Thorough familiarization with the contents of this manual, as well as the installation, commissioning and operation of the air handling unit according to the instructions given and with observance of all health and safety regulations will guarantee a solid basis for efficient, safe and trouble-free operation of the unit.

This document does not cover all possible configurations of these devices, does not give all examples of their assembly and installation, nor does it discuss all aspects of their commissioning, operation, repair and maintenance. If the equipment is used in accordance with its design purpose, both this documentation and any other materials that come with the equipment supplied contain information intended only for qualified technical personnel.



- ! Installation, commissioning and servicing of air conditioning units and their equipment may involve certain safety hazards, hence requires certain knowledge and training.
- ! Equipment improperly installed, adjusted, or repaired by an unqualified person can become the cause of serious injury to individuals, or even their death. The above exempts the manufacturer from liability and warranty and guarantee benefits.
- ! When connecting, servicing and using air handling units, observe all precautions communicated by the manufacturer and those resulting from good practices in the scope of HVAC installations and equipment.
- ! Installation, maintenance and repair must be carried out by qualified technical personnel, or their performance must be supervised by authorized professionals.
- ! By the term qualified technical personnel, we mean trained professionals who, through their professional experience, knowledge of the substantive related standards, documentation and regulations regarding operating procedures and related safety, are authorized to perform the necessary activities, and those who are able to diagnose and correct any potential problems.
- ! Warranty repairs of VTS air-conditioning units may be carried out only by service employees with authorization granted by VTS, confirmed by an appropriate certificate, allowing them to perform this kind of work. We also recommend that service personnel with authorization from VTS carry out installation, commissioning and post-warranty repairs, technical inspections and maintenance work required to be performed on air handling units.
- ! VTS reserves the right to make changes without prior notice.

Floor standing air handling units VENTUS VVS007-VVS650 (AHUs - air handling units). can be installed indoors or outdoors.

The units are designed to cooperate with air duct systems supplying and extracting air from rooms according to the ventilation design for the parameters indicated in the unit selection sheet. Depending on the equipment of the unit and the selection of operating parameters, the units are designed for ventilation, air conditioning or space heating. The units are not designed for use in rooms and for ventilation of rooms in explosive atmospheres (see the requirements of the ATEX Directive 94/9/EC - ATmosphere EXplosive). Duct connection ensures that there is no access to the rotating parts of the device (fan impeller).

The nominal parameters of the device are presented in the selection sheet of the device. Installation of the device outdoors requires the use of roofing and, respectively, air intake and exhaust vents, as well as protection of peripheral automation components from weather conditions.



















GENERAL REQUIREMENTS

- ! The units can operate outdoors in outdoor air temperature ranges from (-40)° C to (+60)° C.
- ! Installed outside the building exchanges:
 - should be equipped with elements to protect them from precipitation and wind, and should be located in such a way as to draw the cleanest and, in summer, coolest air possible under the given conditions,
 - should be equipped with a canopy for protection against precipitation,
 - should be mounted at such a height from the ground to eliminate contact with water or snow,
 - should be equipped with snow protection elements, and the base of the frame should be placed at a level not lower than the highest height of the snow level at that location,
 - should be regularly cleared of snow.
- ! If the unit operates in low air inlet temperature conditions, it is required to use a glycol mixture (up to 45%) as a heating medium. All installation pipes of water heating, condensate drainage, hydraulic valves, should be well insulated and maintained at a positive temperature.
- ! Air damper/air damper actuators should be protected from the weather. If the outside temperature is below (-20) °C, the air damper actuators must be heated. All equipment and components operating outside the unit must have the regulatory required IP rating.
- ! Equipment, periodically stopped during periods of low outdoor temperatures, requires special attention.
- ! It is required to equip the unit with an automation system to ensure its safe and economically optimal operation, as well as to protect the heat exchangers from freezing, both when the unit is operating and when it is idle.



- ! OPENING THE INSPECTION PANELS, DURING THE OPERATION OF THE CONTROL PANEL, OR STARTING THE CONTROL PANEL WITH THE INSPECTION PANELS OPEN IS STRICTLY PROHIBITED.
- ! BEFORE OPENING THE INSPECTION PANELS TURN OFF THE CONTROL PANEL AND WAIT TWO MINUTES FOR ALL ELEMENTS IN MOTION TO STOP.
- ! DISCONNECT AND PROTECT THE POWER SUPPLY FROM UNCONTROLLED STARTUP OF THE CONTROL PANEL.
- ! AUTOMATION SYSTEM IS REQUIRED TO ENSURE CONTROL OF OPTIMAL OPERATION OF THE DEVICE AND TO PROTECT THE DEVICE FROM FAILURE. AUTOMATION MUST INDICATE THE DEGREE OF DIRTINESS OF THE AIR FILTERS.

The device can be equipped with a number of functions, channel functions and accessories, as well as an automation system. The functions of the device and their parameters are given in the selection sheet generated from the manufacturer's information system according to the design guidelines.

FUNCTION		FUNCTION VERSIONS				
F	Air filter		Air filter pre-filter		Air filter secondary	
V	Fan					
H	Heater		Hot Water Heater		Heater Electric	
C	Cooler		Chilled water cooler		Direct Expansion Cooler	
P	PHE		Counter-Flow Recuperator			
R	RHE					
G	Run-around Coils G					
M	Mixing chamber					
S	Noise attenuator					
E	Empty section					

OTHER DESIGNATIONS IN THE CONTROL PANEL

AD	Air damper	
FLX.CON	Flexible duct connection	
IN	Inlet (supply of e.g. medium)	
OUT	Exit (return e.g. medium)	

VENTUS units have inspection panels located at the front of the unit. Units can be made as single-track units (supply or exhaust systems) or as double-track units (supply and exhaust systems). Double-track units most often come with a heat recovery function.

EXAMPLE OF A SINGLE-TRACK DEVICE

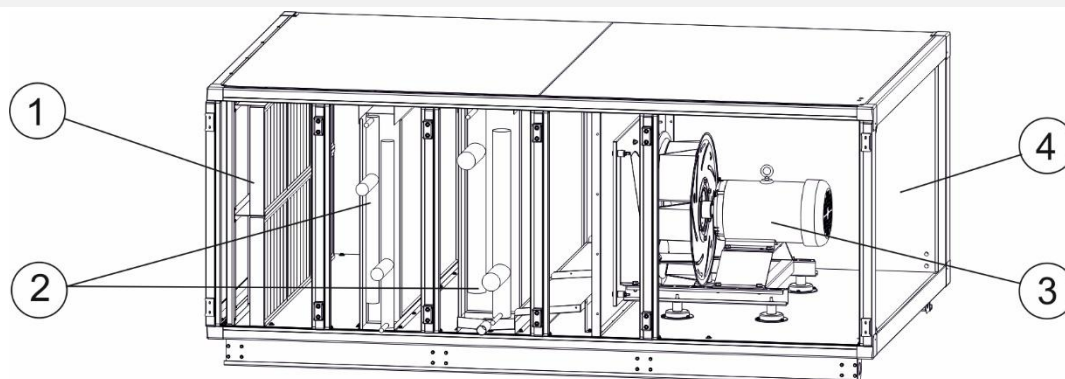

1	Air filter (panel)
2	Air heater and cooler (water)
3	Fan unit (PLUG type with direct fan)
4	Casing

EXAMPLE OF A TWO-TRACK DEVICE

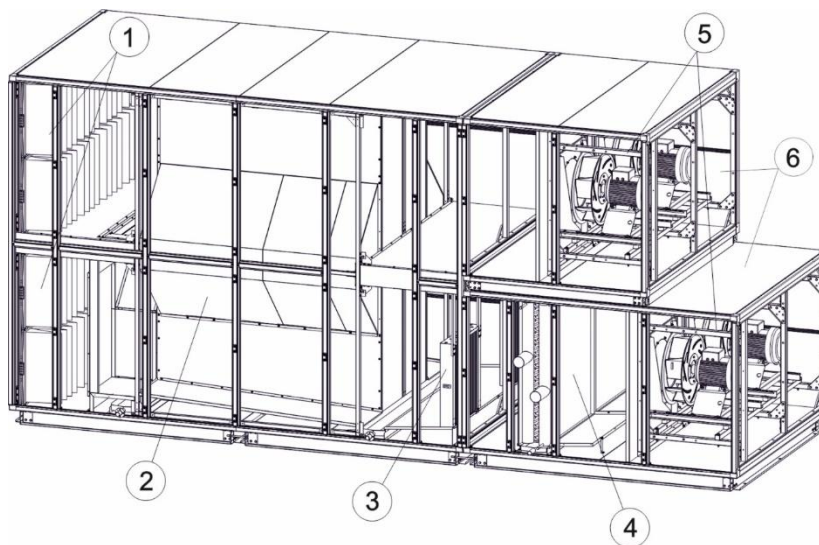

- | | |
|---|--|
| 1 | Air filter (pocket) |
| 2 | Counter-current hexagonal heat exchanger (heat recovery) |
| 3 | Drop-off |
| 4 | Radiator (water) |
| 5 | Fan units |
| 6 | Casing |

The units can be manufactured as right-sided or left-sided. The orientation of the unit is determined by the direction of air flow in the supply track in relation to the side of the unit where the inspection panels are located. If there is no supply track, then the reference is the exhaust track.

**MARKING OF THE AIR INLET AND OUTLET OF THE AIR HANDLING UNIT
INSPECTION SIDE VIEW - RIGHT-HAND EXECUTION**

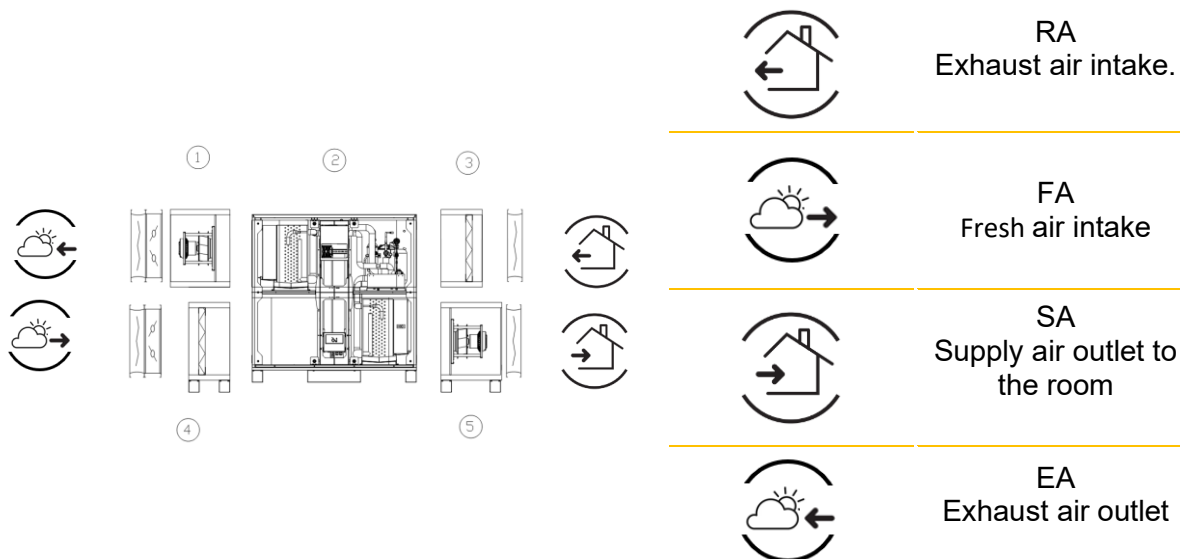

**MARKING OF THE AIR INLET AND OUTLET OF THE AIR HANDLING UNIT
VIEW FROM INSPECTION SIDE - LEFT EXECUTION**

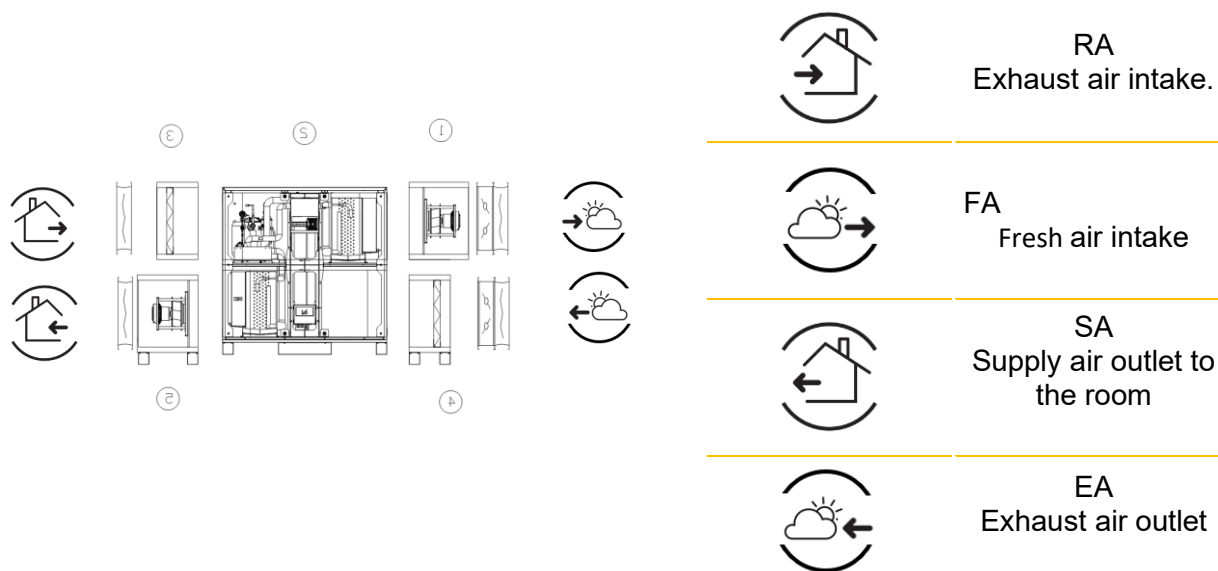

EXAMPLE OF A TWO-TRACK DEVICE

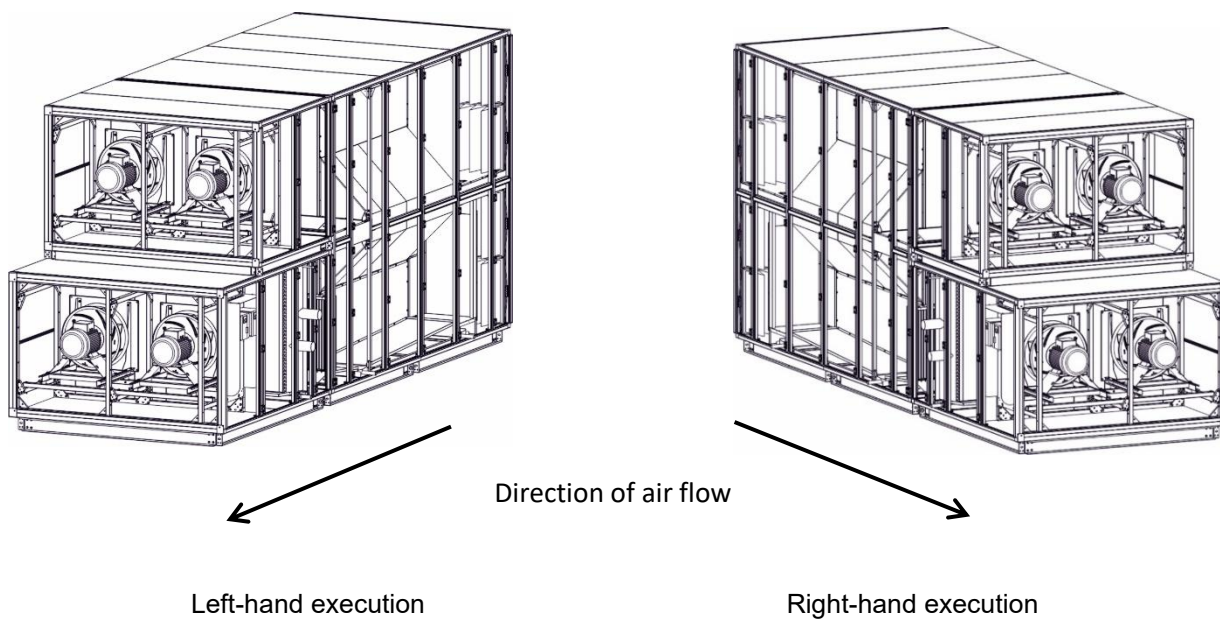

3 TRANSPORTATION AND STORAGE

Air conditioning units are packaged for easy internal transport and storage at the installation site. Upon delivery of the unit, check all components for any damage in transit. Detailed instructions in this regard are included in the table Checklist upon receipt.

Immediately after receiving the shipment with the device, check for transport damage, according to the points of the checklist.

CHECKLIST UPON RECEIPT	
1	Check all individual packages before accepting the shipment. Check packages for damage and completeness according to the bill of lading.
2	If any device (package) appears to be damaged, it should be inspected immediately before accepting the entire shipment. You should also make appropriate, damage-related entries on the waybill. Delivery should not be refused.
3	Inspect the equipment immediately after delivery and before storage for hidden damage. Report hidden damage to the carrier within the time limit set for this purpose from the date of delivery. Check with the carrier on its deadline for filing a claim.
4	Do not move the damaged device from the location to which it was delivered directly from the delivery. It is the responsibility of the recipient of the delivery to provide adequate evidence that the hidden damage has not already occurred after delivery.
5	If the device in question appears to be damaged, stop unpacking it. Preserve all internal packaging, cartons and boxes. If possible, take pictures of the damage.
6	Immediately notify the carrier of the identified damage: by phone and email in accordance with the procedure. Immediate joint damage control by a joint team of the carrier and consignee of the shipment should be requested.
7	Notify the VTS representative of the damage found and make arrangements for repair. The carrier's representative should inspect the damage before repairing it.
8	Compare the electrical data on the unit's nameplate with the data in the order and shipping documentation to verify that the unit received is the correct one.



- ! Any damage resulting from improper transportation, unloading or storage is not covered by the warranty, and any claims submitted for cases of the nature described above will not be considered by VTS.
- ! VENTUS AHUs in the size range VVS021 to VVS650 can be delivered assembled as a whole, in sections (to be connected at the facility) or in packages to be assembled by VTS Authorized Service at the facility (retrofit). This documentation does not include instructions and guidelines for assembly of the units by VTS Authorized Service.
- ! Delivery of control panel components, in the form of closed, properly labeled and undamaged pallets, will pass to the customer after the bill of lading is signed by the customer's representative.
- ! Opening, sealed pallets, by the customer before the arrival of the Authorized VTS Service involves taking full responsibility for the contents and completeness of the delivery.
- ! Immediately upon receipt of the equipment, check the condition of the packaging and the completeness of the delivery based on the attached specifications and waybills.
- ! Unloading parcels with elements of the control panel from the means of transport, transporting them to the place of installation and transporting elements or blocks of the control panel to the place of foundation must be carried out with the help of specialized equipment (e.g.: forklift, crane) and properly qualified personnel.

RULES FOR TRANSPORTING SECTIONS OF AHU'S

- ! Air conditioning units must be transported in the position and manner marked on the original manufacturer's packaging.

VVS021-VVS180	VVS230-VVS650
POSSIBLE TRANSPORTATION	
Switchboard blocks of up to 3,326 m (9M) in layouts: <ul style="list-style-type: none"> • air supply, • exhaust, • supply and exhaust with heat recovery (cross-flow exchanger, hexagonal counter-flow exchanger, rotary regenerator) 	Switchboard blocks of up to 2.195m (6M) in layouts: <ul style="list-style-type: none"> • air supply, • exhaust,
NO POSSIBILITY OF TRANSPORT	
AHU Blocks: <ul style="list-style-type: none"> • Supply and exhaust pipes with a length of more than 3,326 m (9M) • supply and exhaust with heat recovery (cross-flow exchanger, hexagonal counter-flow exchanger, rotary regenerator) with a length of up to 3.326 m (9M) 	AHU Blocks: <ul style="list-style-type: none"> • Supply and exhaust air with a length of more than 6 modules (2195mm), • supply and exhaust with heat recovery (cross-flow exchanger, hexagonal counter-flow exchanger, rotary regenerator)

RULES FOR TRANSPORTING SECTIONS OF AHU

For crane transportation of VVS021-VVS230 air handling units, it is best to use metal brackets and wooden beams. For VVS300-650 air-handling units, use the transport holes in the frames to install a suitable tube crossbar. Spread the slings with appropriate lengths of crossbars.

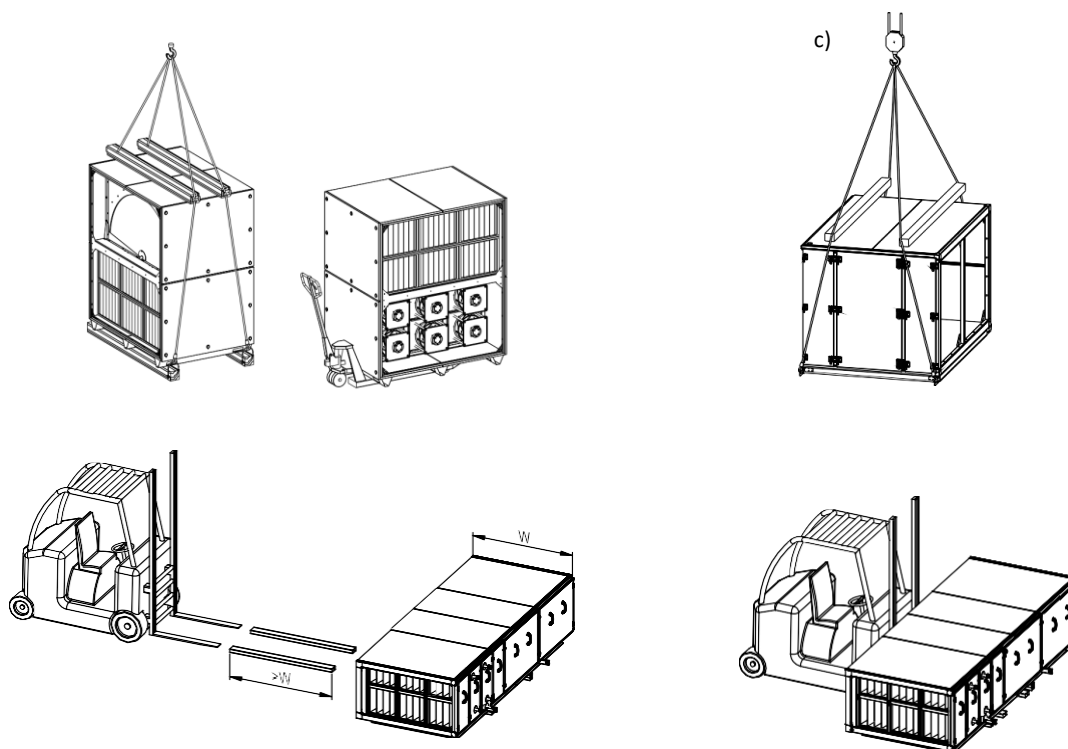

- ! The units should be transported only in their normal operating position and should not be stored by placing one block on top of another.



! **Device Packaging:**

- should be placed in paved, dry areas protected from precipitation,
- should be placed and stored away from areas with active mechanical equipment (vehicles, cranes and other construction machinery),
- should be stored in places where they will not be exposed to any mechanical damage: moisture, aggressive chemicals, liquids, dust and any other external factors, the influence of which may deteriorate their technical and functional condition.
- For the storage period, the plastic packaging must be unsealed.

VTS recommends that panels and their equipment be left in their shipping containers on pallets for protection and to facilitate proper setup during installation.



- ! Devices as well as their components should be:
 - stored in rooms with the following conditions:
 - relative humidity: $\phi < 80 \%$, at $t = (+20) \text{ }^\circ\text{C}$,
 - ambient temperature: $(-40) \text{ }^\circ\text{C} < t < (+60) \text{ }^\circ\text{C}$.
 - protected from contact with corrosive (caustic) dust, gases or vapors, as well as with any other chemical substances that may have a corrosive effect on the equipment or its accessories.
- ! The inside of the air handling unit and all unit components, in particular air filters, must be protected against moisture and contamination from the surroundings, such as dust, dirt and other impurities.
- ! The air filters should be stored in their original packaging or in another manner that provides protection against contamination.
- ! All air filters must also be protected against direct sunlight, which may adversely affect the filter media and structural components of the filter. It is recommended to store filters in a dry, clean and shaded place.

4 INSTALLATION OF THE DEVICE

Transportation of equipment requires lifting equipment at the installation site. Make sure that there will be enough space to properly bring the technological and electrical installations to the unit after installation, and to carry out maintenance on the unit without problems.

4.1 LOCATION OF THE DEVICE (PLACE OF FOUNDATION)

Allow adequate space for the placement of piping and electrical connections. All piping and ductwork should be fixed independently of the air handling unit to reduce excessive noise and vibration.

RECOMMENDATIONS FOR LOCATING THE DEVICE

1	The weight of the device should be considered. When doing so, refer to the weight of the device on its nameplate. The weight on the nameplate does not consider the weight of the media, which should be taken into account when installing the device.
2	All equipment must be mounted horizontally.
3	Consider the requirements for proper installation of the U-TRAP.
4	Consider the requirements for coil and drain piping and condensate drainage.
5	Consider the requirements for conducting maintenance work.

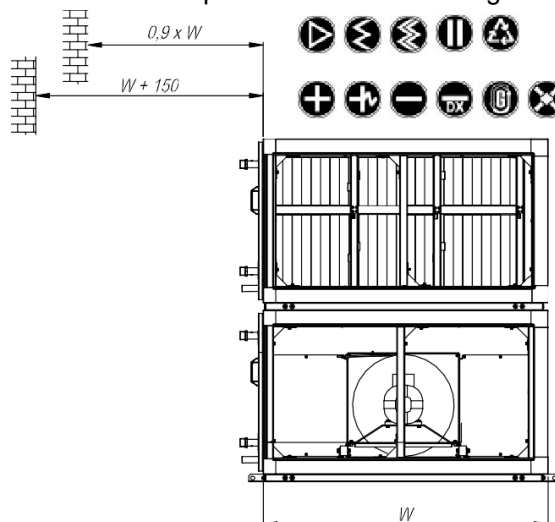

Sufficient space should be left to allow removal of the enclosure panels and for access to maintenance work.

In the service space it is allowed to install installations, pipelines, support structures only in a way that allows easy removal and installation for servicing, repair and overhaul.

4.1.1 REQUIREMENTS FOR THE DEVICE TO BE INSTALLED ON THE SITE - DELIVERY IN PACKAGES



PREPARATION OF UNIT ASSEMBLY

- ! Before the installation of the unit begins, VTS will send the customer a document entitled "Confirmation of readiness for installation". The document contains the necessary information about the installation process. Once the conditions specified therein are met, the document should be signed at the indicated location and sent to the designated VTS entity.
- ! Sending the Confirmation of Readiness for Installation is necessary for the Authorized Service Provider to begin the installation process. If the actual conditions do not correspond to the information provided in the Confirmation, VTS has the right to request reimbursement of the costs incurred in connection with the interruption of service work or additional activities performed by the service on site.

BASIC CONDITIONS OF INSTALLATION ON THE SITE - DELIVERY IN PACKAGES

1	Installation must be carried out on a hardened and dry surface. A hardened surface is considered a flat, level and hard surface, which does not change its properties under the influence of weather conditions and is resistant to any damage associated with the placement of the AHU on it, as well as regular operation. Preparation of the installation site of the unit is on the side of the customer.
2	Installation can be carried out at ambient temperatures that allow the proper execution of all technical procedures of installation, i.e. in the temperature range: from (+5)° C to (+35) C°
3	In the case of outdoor installation, the installation process can be carried out in conditions that ensure the absence of precipitation. It is permissible to begin installation provided that all safety requirements are met.
4	Minimum mounting surface dimensions: <ul style="list-style-type: none"> • AHU width +4 meters (2 meters on each side of the unit), • AHU length +4 meters (2 meters on each side of the device).
5	Installation is carried out at the site of the device foundation. Preparation of the device foundation site (frame, foundation, etc. is on the customer's side). Pay attention to the requirements described in this manual.
6	For the installation site, the following are required: <ul style="list-style-type: none"> • access to power 1~ 230V, • Adequate illumination of the installation site, • Ensuring a safe environment for the installation team, • The availability of individual pieces of equipment or pallets including packaging at the site of installation of a particular unit, • Provides transportation of AHU components and AHU blocks to the installation site, • The ability for the service to enter the site and begin installation immediately upon arrival, • Providing the warranty card and delivery documents of a specific unit for the installation service.

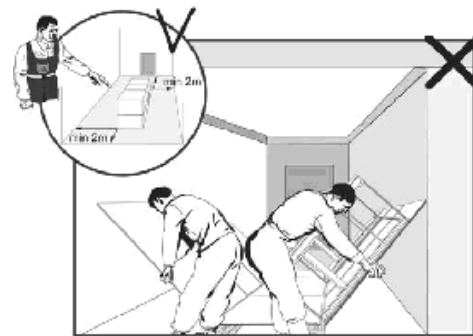
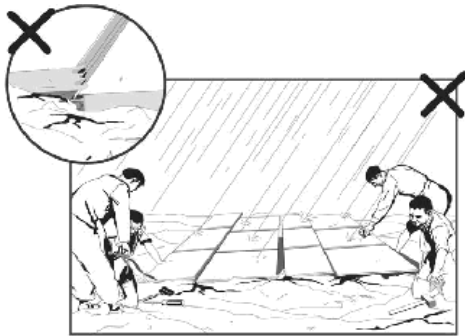

! ENSURING THE ABOVE CONDITIONS IS ON THE SIDE OF THE CUSTOMER

In the case of a unit delivered in parcels, VTS provides free assembly and installation within 200 km of the location of the nearest authorized service in the country where VTS has representatives. A list of authorized VTS services is available at: www.vtsgroup.com.

If the installation is to be carried out at a location more than 200 km from the nearest VTS service company, the customer is required to cover:

- Transportation costs of the authorized VTS service resulting from excessive distance,
- Accommodation and meals for the authorized VTS service crew.

Installation of the unit can only be carried out by a service that has the appropriate VTS authorization certificate to provide such a service.

According to the offer presented, the scope of standard services does not include connection of AHU sections, connection of power supply, automation control, wiring of the unit, frequency converters, as well as does not include connection of units to ventilation ducts.



COMPLETION OF ASSEMBLY

! Upon completion of the installation, the service is required to:

- notify the customer's representative of the fact that the installation has been completed,
- Commissioning of a clean control panel marked with the provided VTS pictograms and labels, ready for connection to the power source (wiring), tools and control systems,
- transfer automation components to the customer representative if they have not been assembled in the AHU at the customer's request,
- Provide the customer with a complete VTS Warranty Card,
- provide documentation signed by the customer and provide a copy of this document,
- place the assembly waste in the place indicated by the customer's representative not more than 20 meters from the installation site,
- Leave the installation site in the same condition as before installation.

! Installation of equipment delivered in packages performed by VTS does not include:

- preparation of the electrical system, power circuits, connection of the heating medium, refrigerant and installation of the exchanger valve,
- wiring, installation (except for damper actuator, pressure switch, and antifreeze thermostat) and commissioning of automation components, and resetting of equipment motors,
- foundation, leveling and anchoring of equipment,
- Connecting equipment to the ventilation ducts, hydraulic and electrical connections,
- equipment commissioning,
- disposal of packaging in which the equipment was delivered

4.1.2 REQUIREMENTS FOR THE DEVICE TO BE INSTALLED ON THE SITE - DELIVERY IN SECTIONS

BASIC CONDITIONS FOR INSTALLATION ON THE SITE - DELIVERY IN SECTIONS	
1	Section connection is beyond the standard offer of VTS. It is possible to purchase an additional option of section connection by VTS Authorized Service.
2	Installation can be carried out at ambient temperatures that allow the proper execution of all technical procedures of installation, i.e. in the temperature range: from (+5)° C to (+35) C°
3	In the case of outdoor installation, the installation process can be carried out in conditions that ensure the absence of precipitation. It is permissible to begin installation provided that all safety requirements are met.
4	Installation is carried out at the site of the device foundation. Preparation of the device foundation site (frame, foundation, etc. is on the customer's side). Pay attention to the requirements described in this manual.
5	For the installation site, the following are required: <ul style="list-style-type: none"> • access to power 1~ 230V, • Adequate lighting of the installation site, • Ensuring a safe environment for the installation team, • The availability of individual unit components or pallets including packaging at the site of installation of a particular unit, • Provides transportation of AHU components and AHU blocks to the installation site, • The ability for the service to enter the site and begin installation immediately upon arrival, • Provide the warranty card and delivery documents of the specific PBX for the installation service.
6	When installing on your own, follow the separate instructions provided with the AHU in the installation kit. The instructions are available on the manufacturer's website.
7	When connecting the section, it is necessary to pay attention to the correct application of the gasket "D", which is part of the section assembly kit (a connection made without using the enclosed gasket will result in a lack of tightness of the Casing - warranty claims for this reason will not be considered).

4.2 FOUNDATION OF THE DEVICE OF VENTUS AHU



- ! The control panel should be located on:
 - foundation screed,
 - Concreted into the floor of a steel foundation frame,
 - specially prepared rigid steel structure
- ! The foundation, frame or steel structure must be flat and level, and should have sufficient strength to match the weight of the control panel along with the weight of the media.
- ! The foundation, frame or steel structure must be flat and level, and should have sufficient strength to match the weight of the panel.
- ! In stacked AHUs, the part of the upper AHU that protrudes beyond the outline of the lower AHU must be supported by a suitable support structure (See SUPPORTING TOP AHU BLOCKS).
- ! The height of the screed or foundation frame must take into account the installation of a U-TRAP draining condensate from the drip tray. For drip trays installed in the lower sections of the air handling unit, it is necessary to provide for the foundation of the air handling unit on an additional foundation or to make a depression in the floor directly under the U-TRAP. (See condensate drainage).

SUPPORT OF THE UPPER BLOCKS OF THE EXCHANGES

- ! In stacked panels, the part of the upper panel that protrudes beyond the contour of the lower panel must be supported by an appropriate support structure

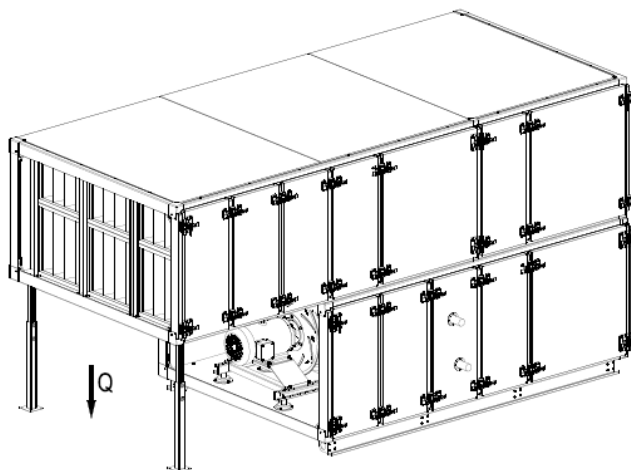

AHU	Q [N]
VVS021	500
VVS030	500
VVS040	500
VVS055	1000
VVS075	1000
VVS100	1500
VVS120	2000
VVS150	2000
VVS180	3500
VVS230	4000
VVS300	5000
VVS350	6000
VVS400	6000
VVS450	8500
VVS500	8500
VVS575	9000
VVS650	9000

4.2.1 HV FRAME

FRAME "HV" (HALF V)

AHU VVS021-VVS075

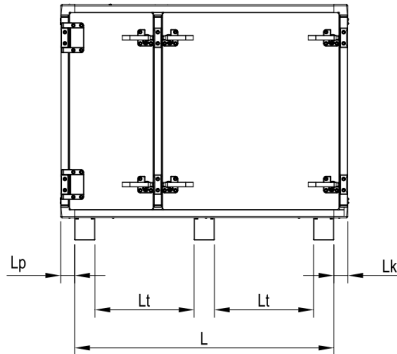

VVS021-VVS075(*)

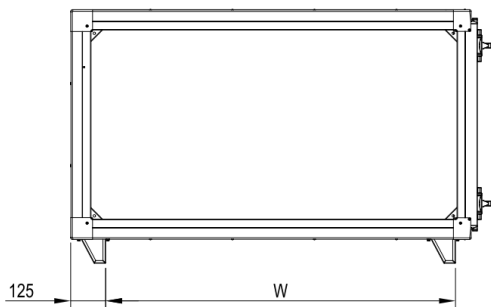

VVS100-VVS230(*)

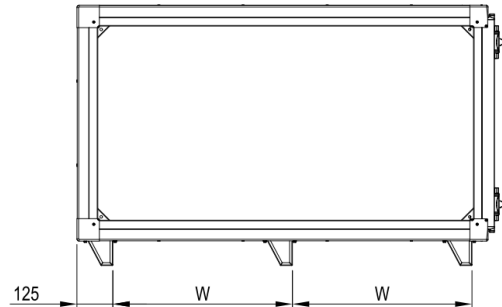

(*) - excluding the HEX section (with a countercurrent recuperator type HEX).
 $L_p=54\text{mm}$, $L_k=54\text{mm}$

HEX BLOCK VVS021-VVS075

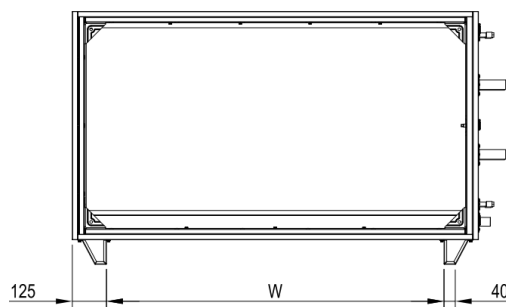

HEX BLOCK VVS100-VVS150

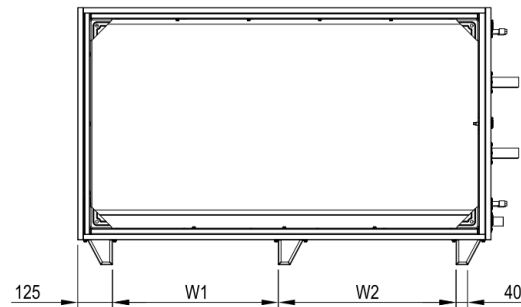

W [mm].

VVS021-VVS150				HEX BLOCK VVS021-VVS150							
VVS	W [mm].	VVS	W [mm]	VVS	W [mm]	W1 [mm]	W2 [mm].	VVS	W [mm]	W1 [mm]	W2 [mm].
VVS021	761	VVS100	730	VVS021	717	336	380	VVS100	1416	686	730
VVS030	761	VVS120	845	VVS030	717	336	380	VVS120	1647	801	845
VVS040	968	VVS150	942	VVS040	924	440	484	VVS150	1841	898	942
VVS055	1139	VVS180	942	VVS055	1095	525	569				
VVS075	1280	VVS230	1146	VVS075	1236	596	640				

Full dimensional data for specific device configurations are available in the device selection sheet.

DIMENSIONS OF HV FRAME PROFILES								
MODULARITY OF SECTIONS	SECTION LENGTH	PROFILE 1	PROFILE 2	PROFILE 3	PROFILE 4	PROFILE 5	PROFILE 6	PROFILE 7
1	366	[mm]	[mm]	[mm]	[mm]	[mm]	[mm]	[mm]
2	758	80	80	80				
3	1124	80	80	80				
4	1490	80	400	80				
5	1856	80	840	80				
6	2221	80	1220	80				
7	2587	80	1600	80				
8	2953	400	1600	400				
9	3318	400	1600	400				
10	3684	1600	1600					
11	4050	1600	400	1600				
12	4415	1600	840	1600				
13	4781	1600	1220	1600				
14	5147	1600	1600	1600				
15	5513	1600	1220	840	1600			
16	5878	1600	1220	1220	1600			
17	6244	1600	1600	1220	1600			
18	6610	1600	1600	1600	1600			
19	6975	1600	1600	400	1600	1600		
20	7341	1600	1600	400	1600	1600		
21	7707	1600	1600	840	1600	1600		
22	8072	1600	1600	1220	1600	1600		
23	8438	1600	1600	1600	1600	1600		
24	8804	1600	1600	1220	840	1600	1600	
25	9170	1600	1600	1220	1220	1600	1600	
26	9535	1600	1600	1600	1220	1600	1600	
27	9901	1600	1600	1600	1600	1600	1600	
28	10267	1600	1600	1600	400	1600	1600	1600
29	10632	1600	1600	1600	840	1600	1600	1600
30	10998	1600	1600	1600	1220	1600	1600	1600

MODULARITY OF SECTIONS	SECTION LENGTH	PROFILE 1	PROFILE 2	PROFILE 3	PROFILE 4	PROFILE 5	PROFILE 6	PROFILE 7
	[mm]	[mm]	[mm]	[mm]	[mm]	[mm]	[mm]	[mm]
2	758	80	80	80				
3	1124	80	80	80				
4	1490	80	400	80				
5	1856	80	840	80				
6	2221	80	1220	80				
7	2587	80	1600	80				

FIXING OF THE FRAME "HV" (FEET) TO THE GROUND

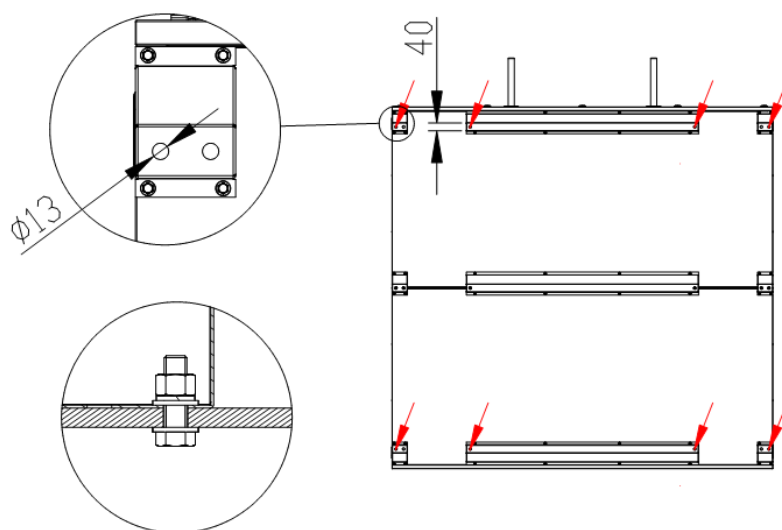

!

! Attach the frame through the extreme holes in the feet/frame.

!

- ! All profiles of the panel frame must be supported.
- ! Use M10 bolts or dowels to attach the frames to the foundation.
- ! The extreme foundation holes in the longitudinal profiles of the frames can be used for anchoring the HV frames.

4.2.2 "C" SHAPE BASE FRAME

RAMA „C” 120x60 AHU VVS021-VVS650

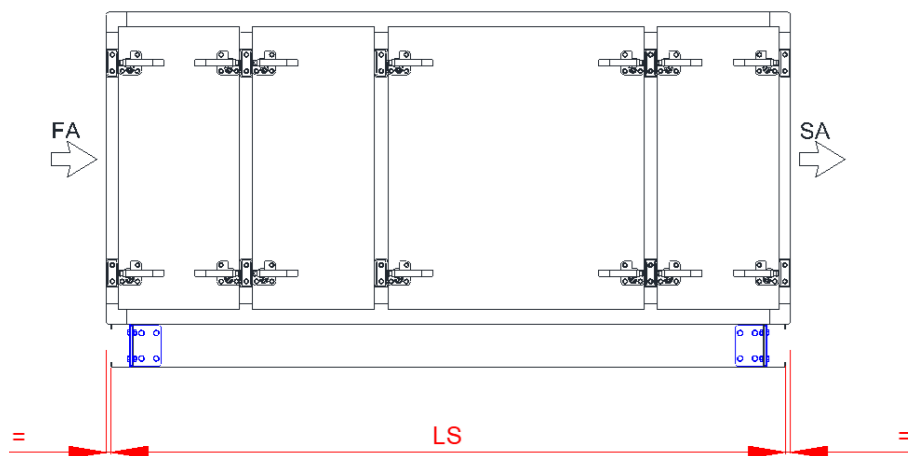

INSULATION 40mm

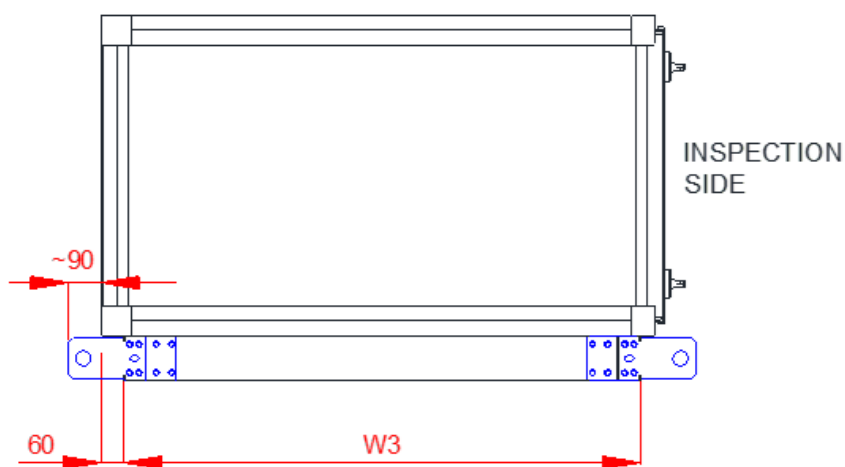

INSULATION 50mm

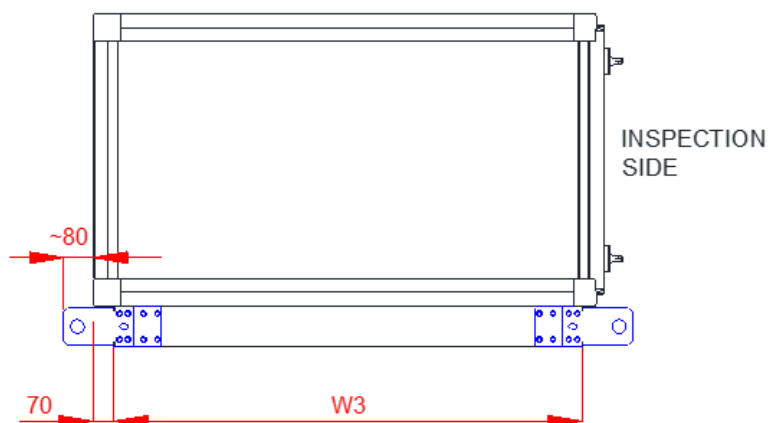

USUWANIE UCHWYTÓW TRANSPORTOWYCH AHU VVS021-VVS650

UWCHWYTY TRANSPORTOWE POWINNY BYĆ USUNIĘTE PO POSADOWIENIU URZĄDZENIA

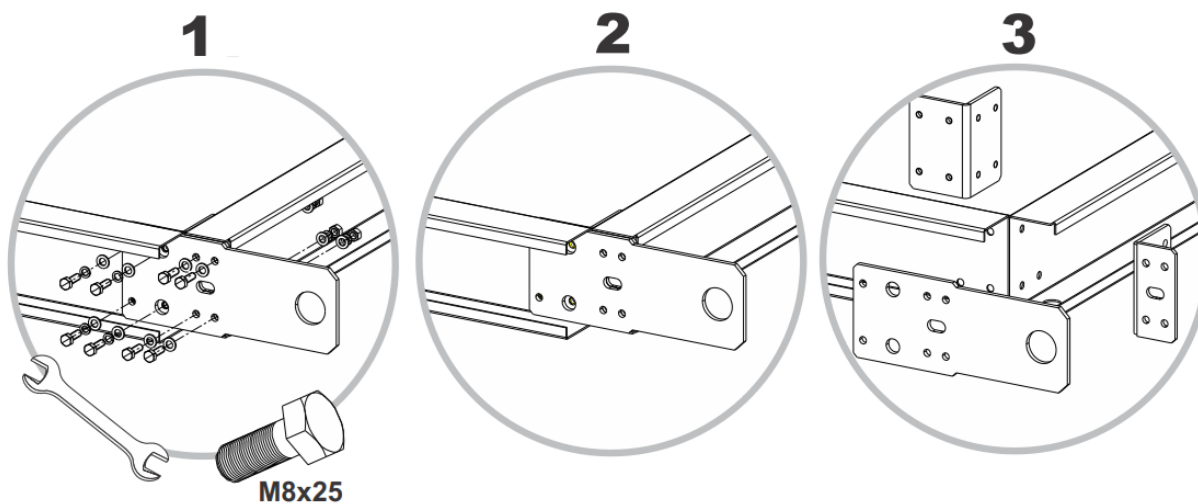

RAMA „C” 120x60 AHU VVS021-VVS650

VVS021-VVS650

VVS021-VVS230

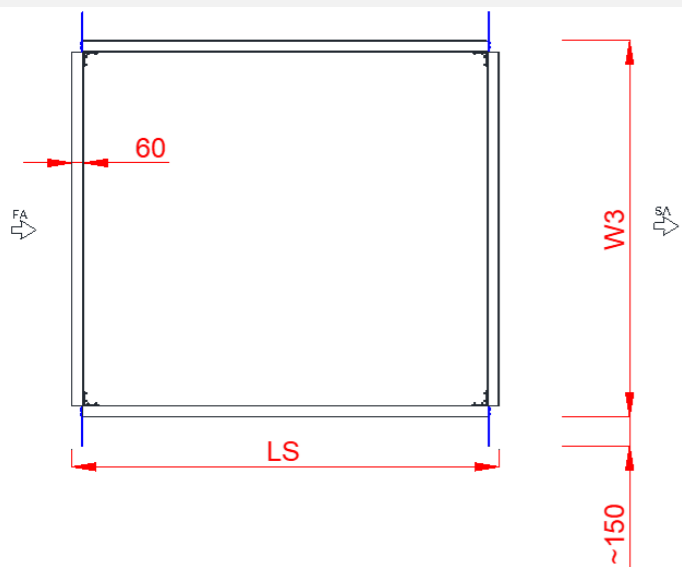
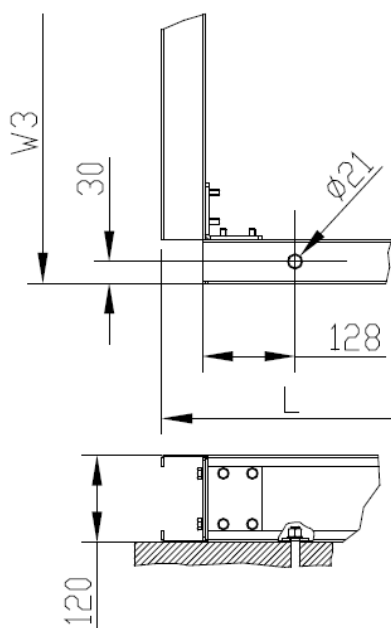

VVS300-VVS650

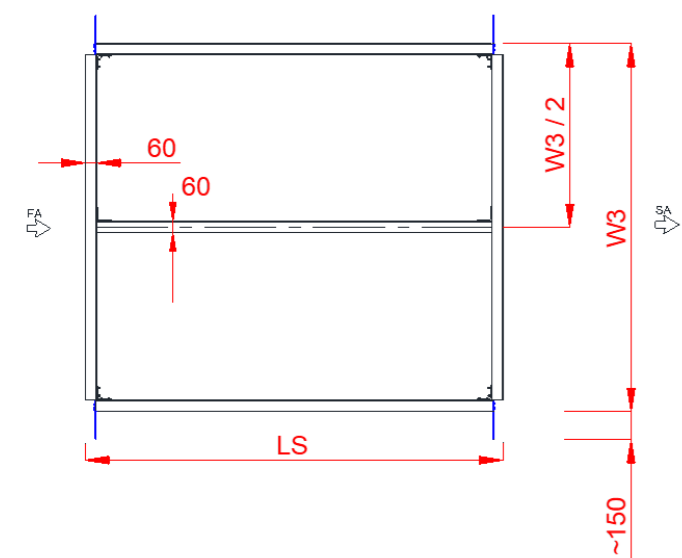

REGUŁY KOMPOZYCJI PROFILI WZDŁUŻNYCH RAMY "C" VVS021-VVS300								
SEKCJA	PROFIL WZDŁUŻNY RAMY							
	2MOD	3MOD	4MOD	5MOD	6MOD	7MOD	8MOD	9MOD
2M	1							
3M		1						
4M			1					
5M				1				
6M					1			
7M						1		
8M							1	
9M								1
10M				2				
11M				1	1			
12M					2			
13M					1	1		
14M						2		
15M						1	1	
16M							2	
17M							1	1
18M								2
19M					2	1		
20M					1	2		
21M						3		
22M						2	1	
23M						1	2	
24M							3	
25M							2	1
26M							1	2
27M								3
28M						4		
29M						3	1	
30M						2	2	

1M = 366mm, Section length x * M + 27

COMPOSITION OF LONGITUDINAL BASE FRAME SECTIONS VVS300-VVS650								
Section	LONGITUDINAL PROFILE							
	2MOD	3MOD	4MOD	5MOD	6MOD	7MOD	8MOD	9MOD
2M	1							
3M		1						
4M			1					
5M				1				
6M					1			
7M		1	1					
8M			2					
9M			1	1				
10M				2				
11M				1	1			
12M					2			
13M			2	1				
14M			1	2				
15M				3				
16M				2	1			
17M				1	2			
18M					3			
19M			1	3				
20M				4				
21M				3	1			
22M				2	2			
23M				1	3			
24M					4			
25M				5				
26M				4	1			
27M				3	2			
28M				2	3			
29M				1	4			
30M					5			

1M = 366mm, Section length x * M + 27

4.3 CONNECTING AIR DUCTS

INSTALLATION OF AIR DUCTS

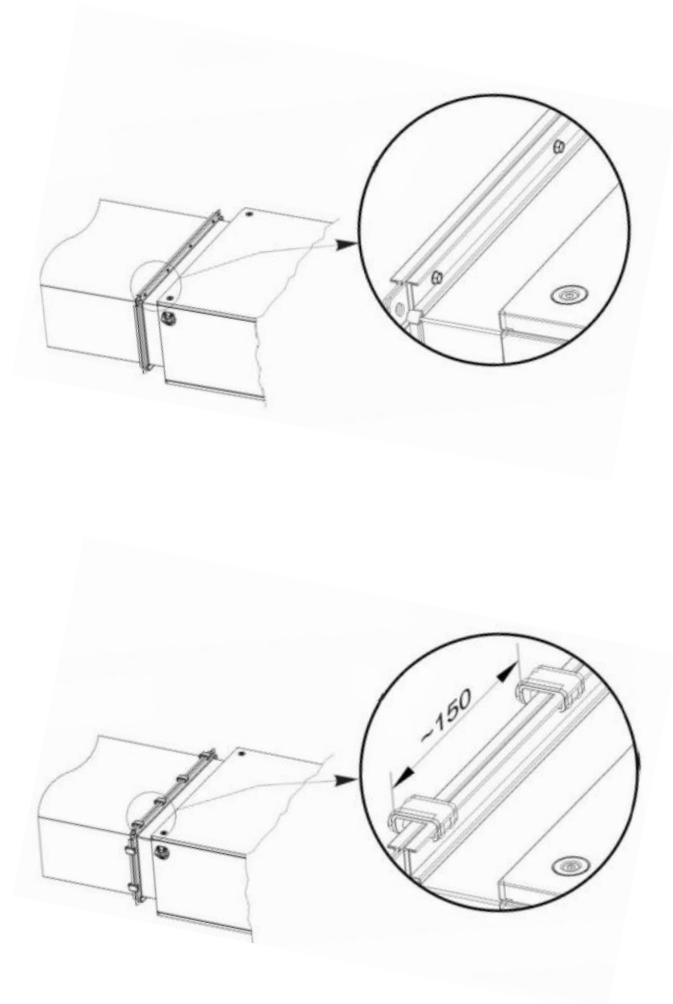

Air ducts should be connected to the air handling unit with flexible connections (optional equipment) that dampen unit vibrations and compensate for misalignment of duct and unit outputs.

Flexible connections are equipped with sealed flanges. Flexible flanges should be connected to channels with self-tapping screws or additional clamping elements.

The components used to connect the channels are not included in the standard delivery.

Air ducts must not rest their weight on the unit! Ducts connected to the air handling unit must be supported or suspended on their own support elements.

The method of routing the ducts with fittings should eliminate the possibility of increasing the noise level in the ventilation installation

Proper functioning of the flexible connection is ensured when the sleeve is stretched to a length of about 110 mm.

4.4 CONNECTING SECTIONS VVS021-VVS150

SECTION ASSEMBLY - FASTENERS

ELEMENTS



M10 x 120



M8x50



large 8
large 6



M8
M19



ST 5,5x63

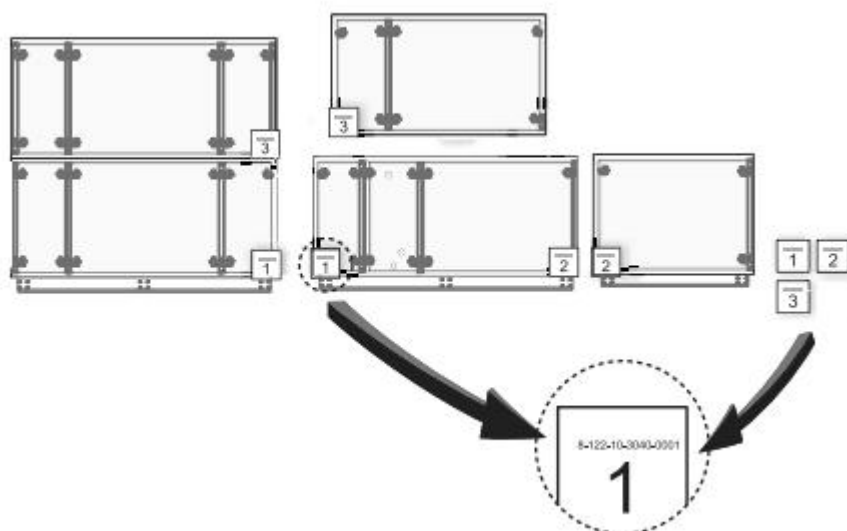

SECTION ASSEMBLY STEP 1

STEP 1

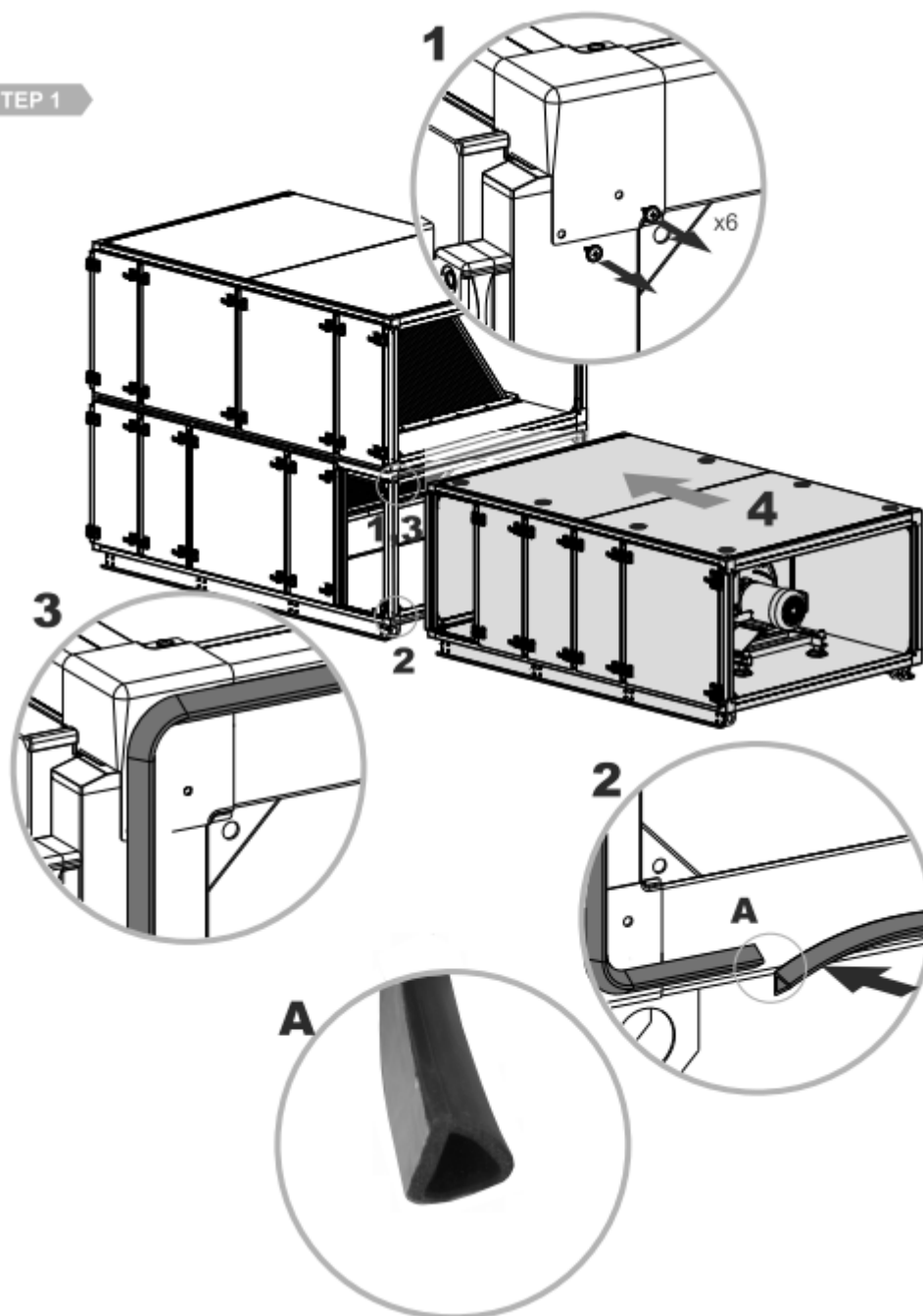

SECTION ASSEMBLY STEP 2

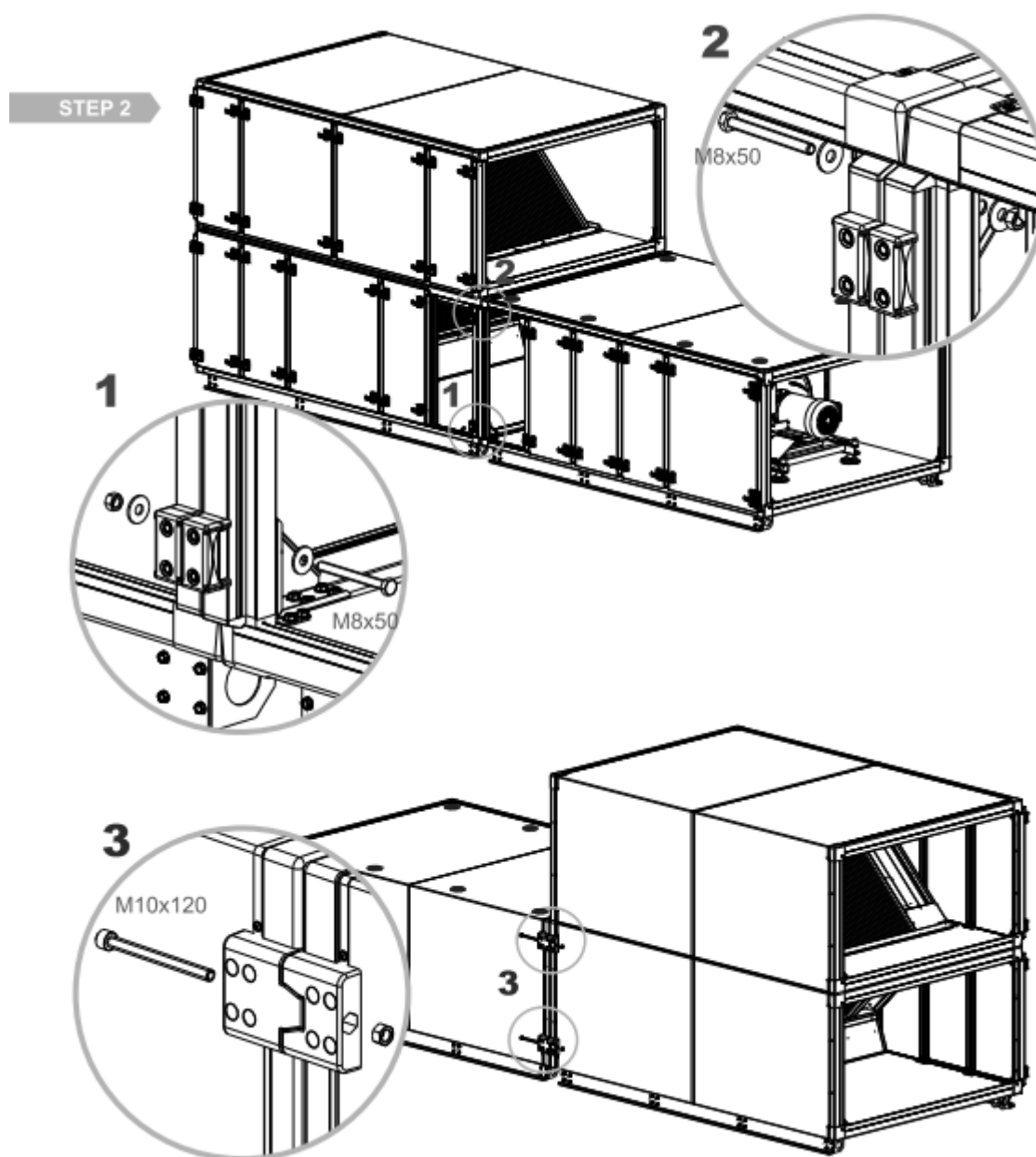

ASSEMBLY OF SECTION STEP 3 & 4

STEP 3

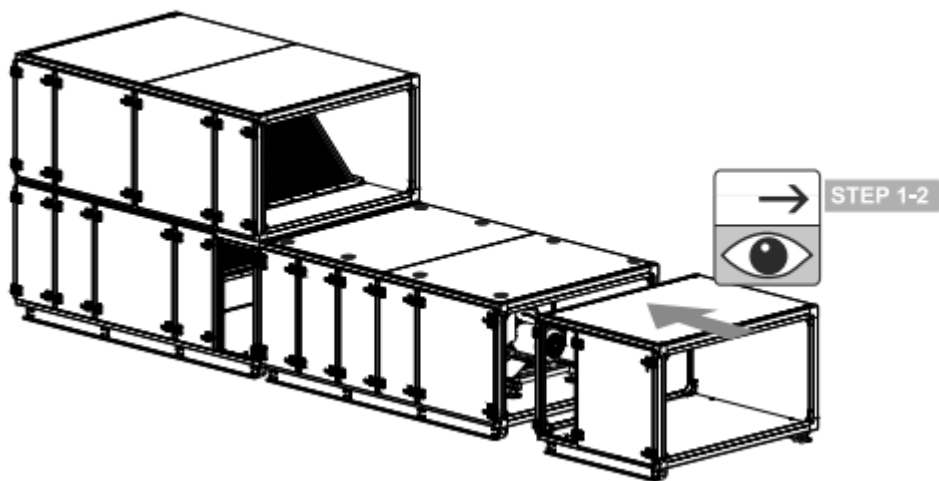

STEP 4

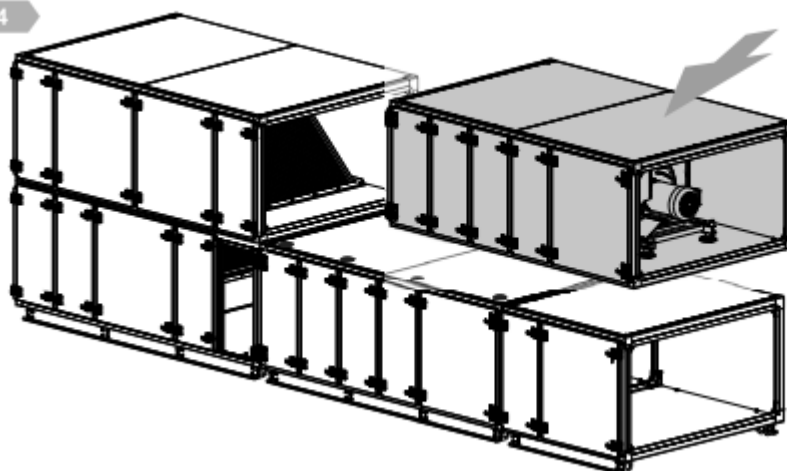

ASSEMBLY OF SECTION STEP 5 & 6

STEP 5

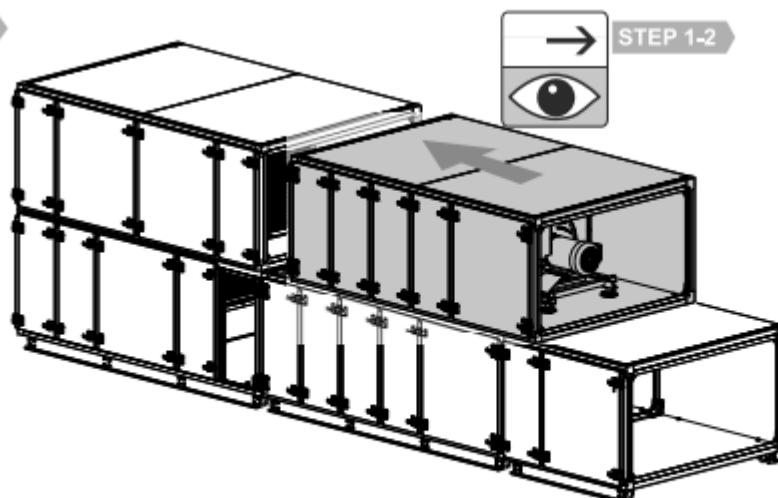

STEP 6

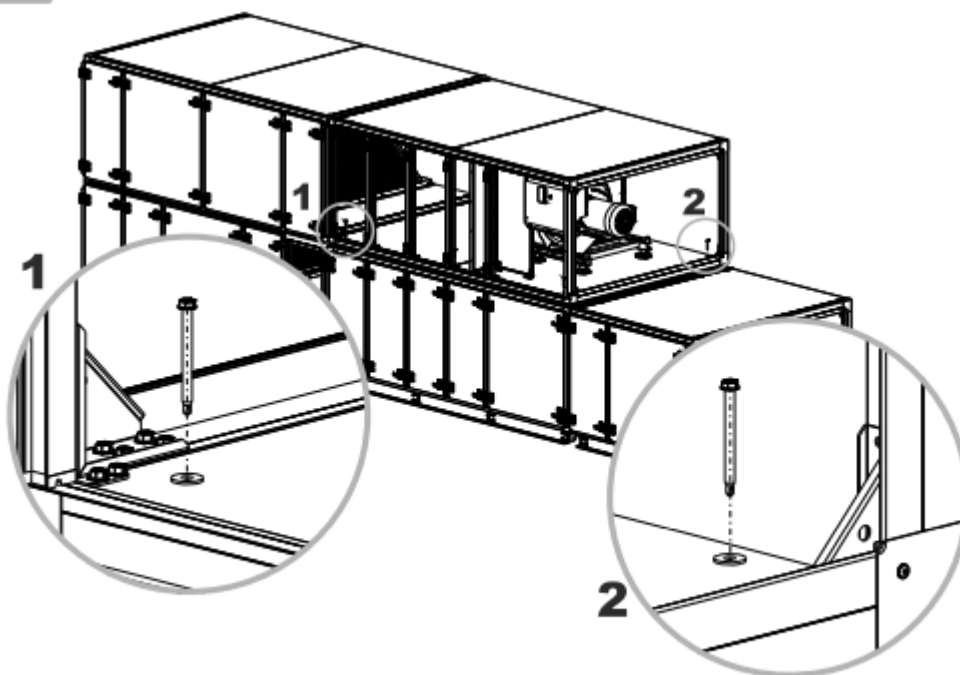

4.5 CONNECTING VVS180-VVS650 SECTIONS

SECTION ASSEMBLY - FASTENERS

ELEMENTS



M10x120



M8x50
M12x200



large 6
large 8
large 12



M8
M10
M12



ST #5.5x63

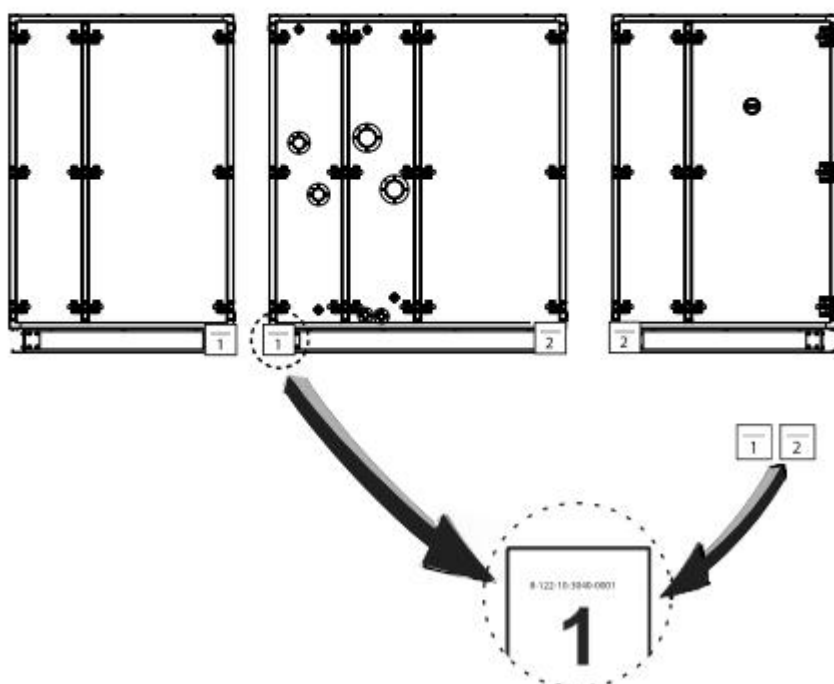

SECTION ASSEMBLY STEP 1

STEP 1

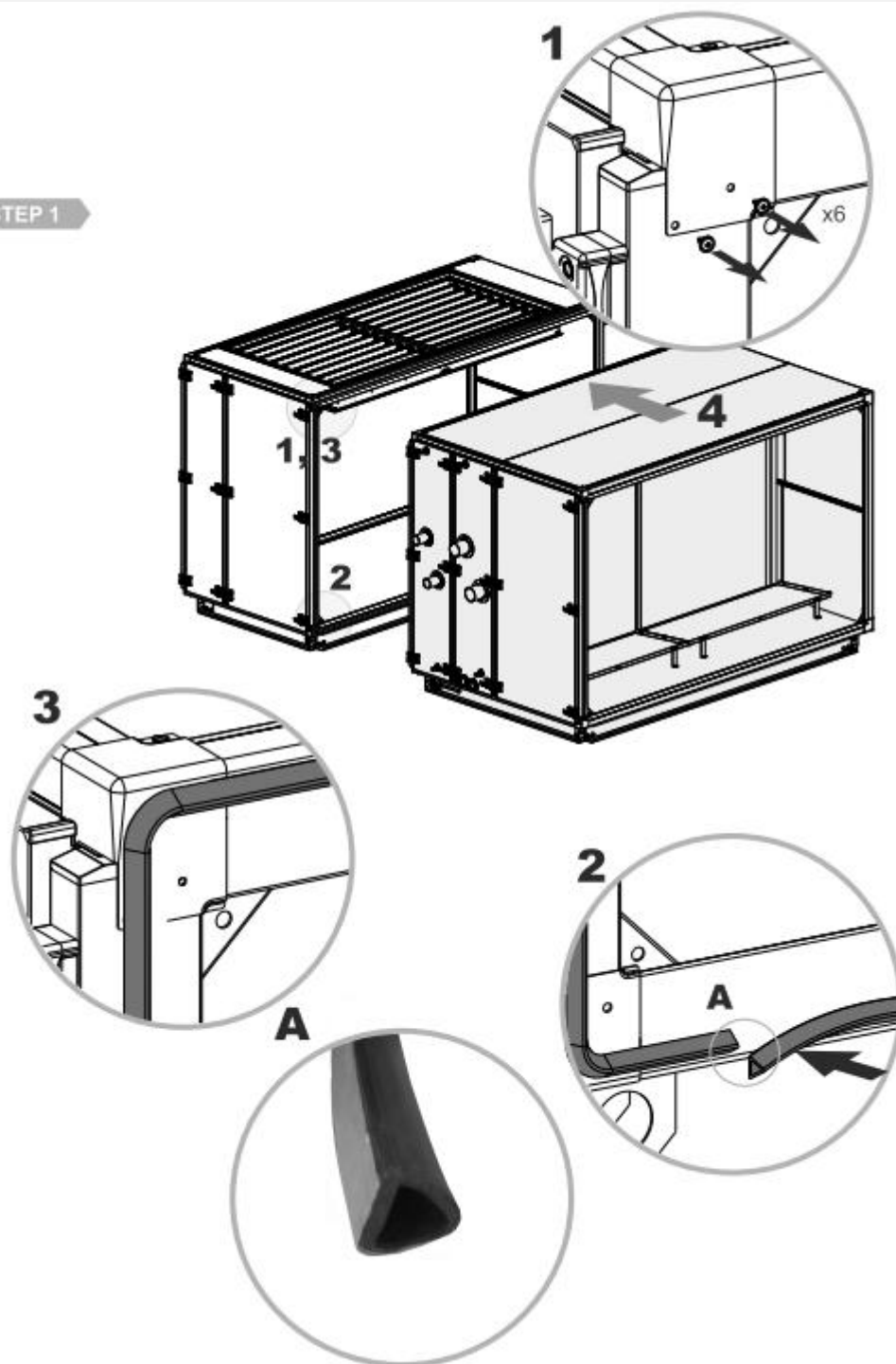

SECTION ASSEMBLY STEP 2

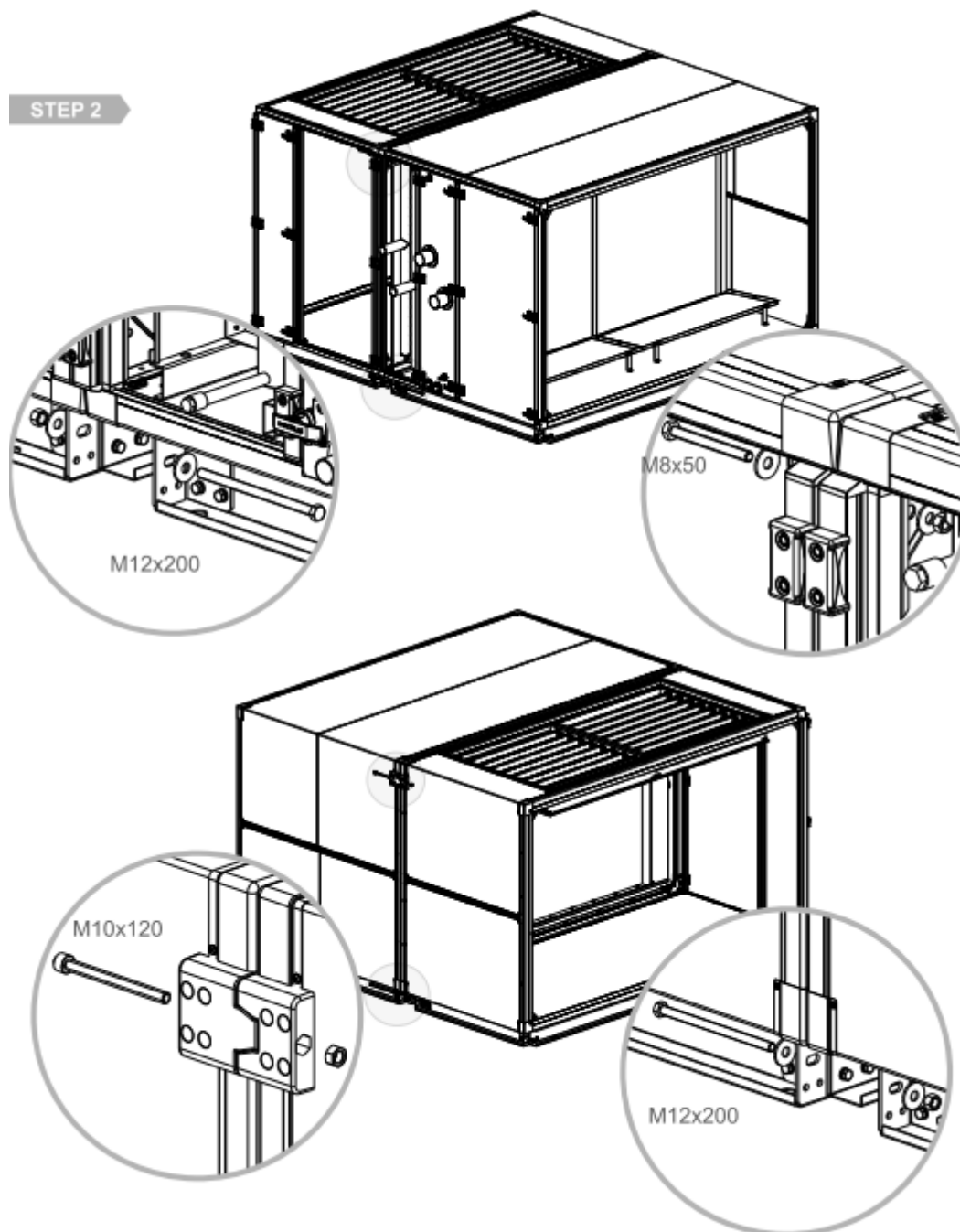

SECTION ASSEMBLY STEP 3

STEP 3

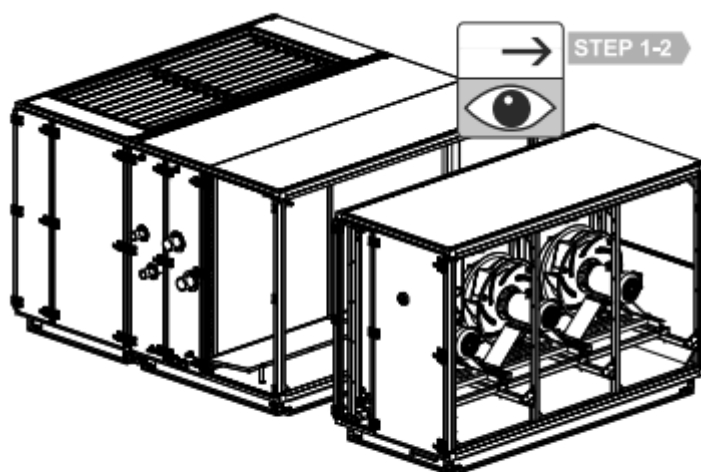

SECTION ASSEMBLY STEP 4

STEP 4

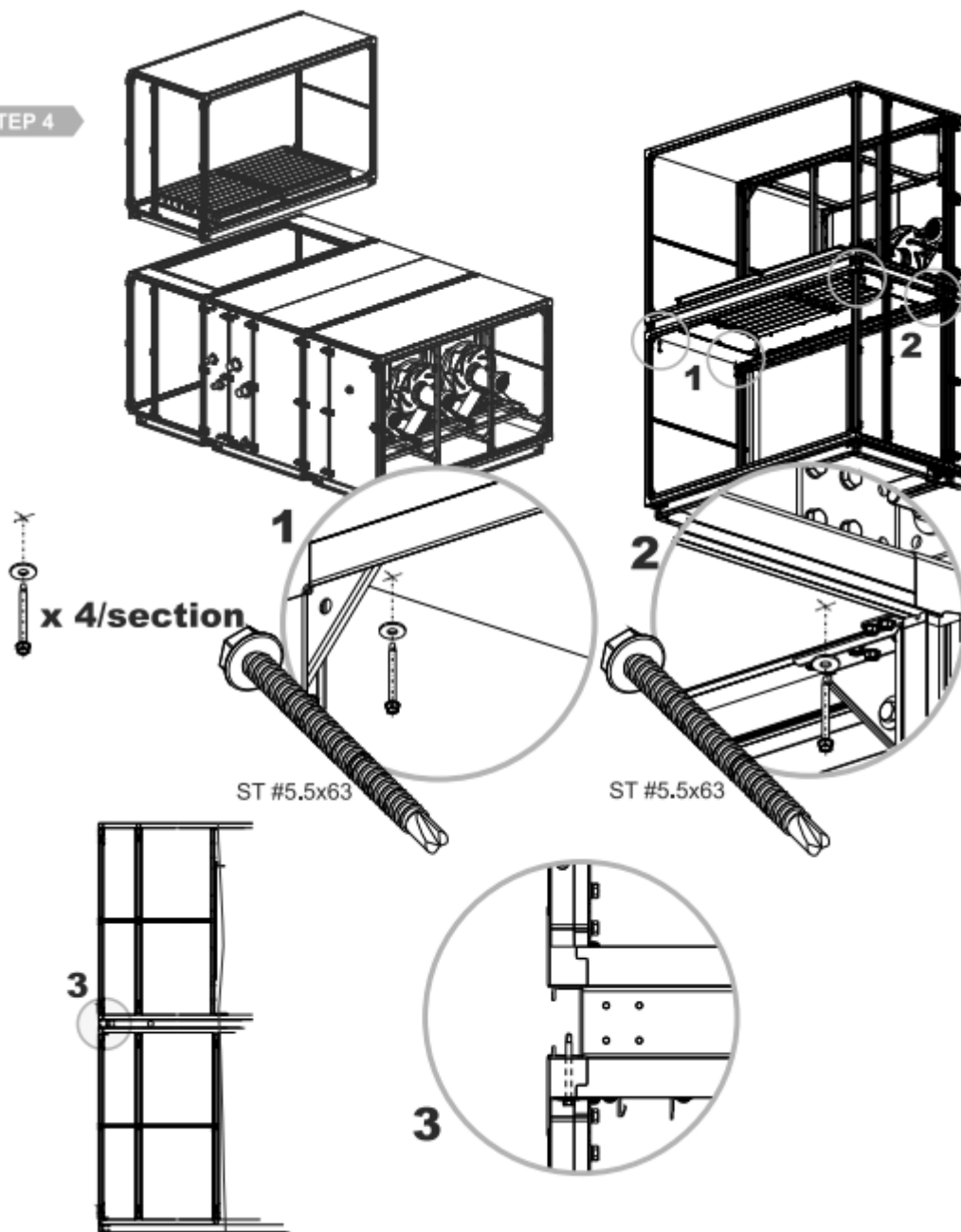

SECTION ASSEMBLY STEP 5

STEP 5

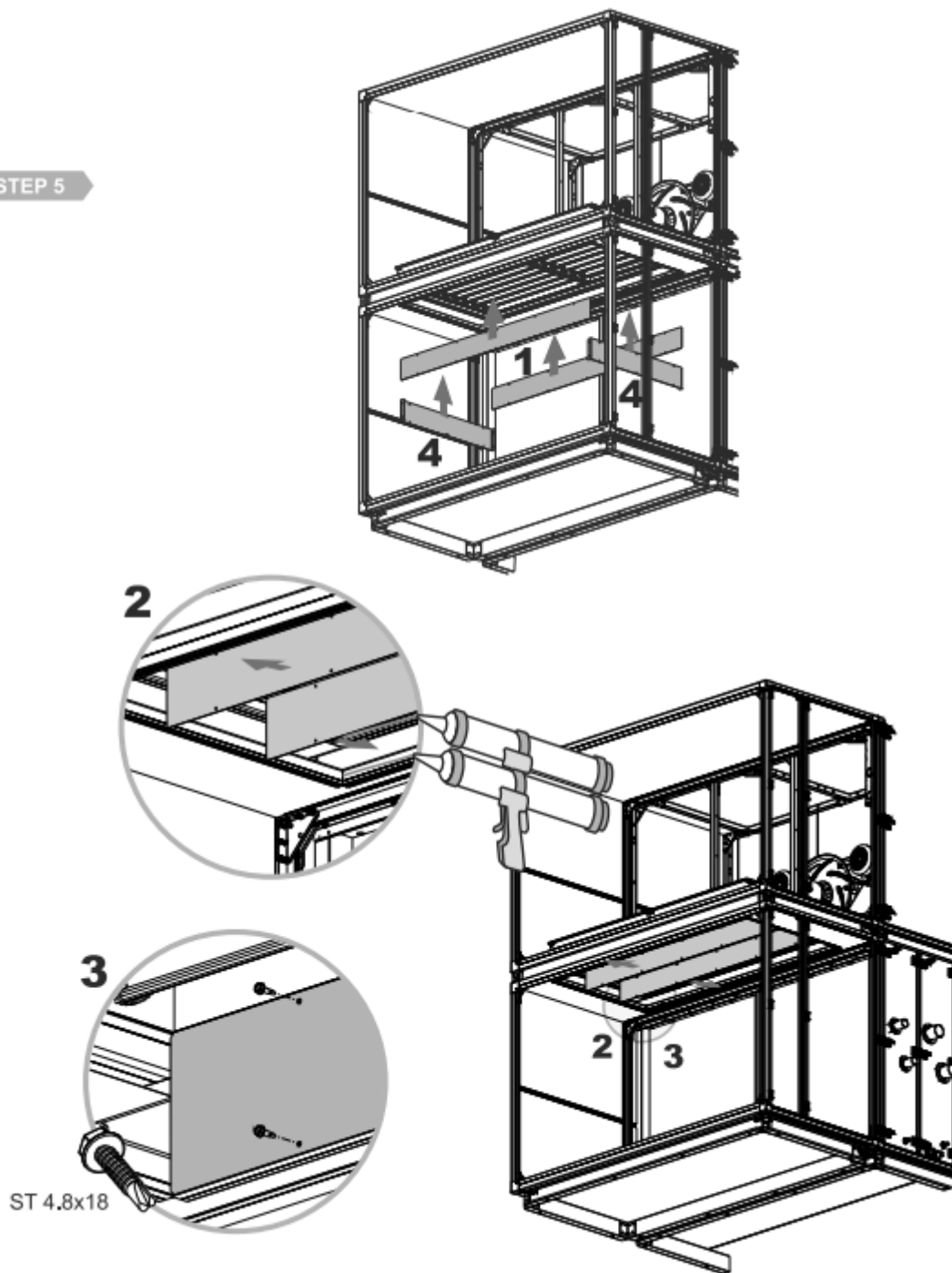

SECTION ASSEMBLY STEP 6

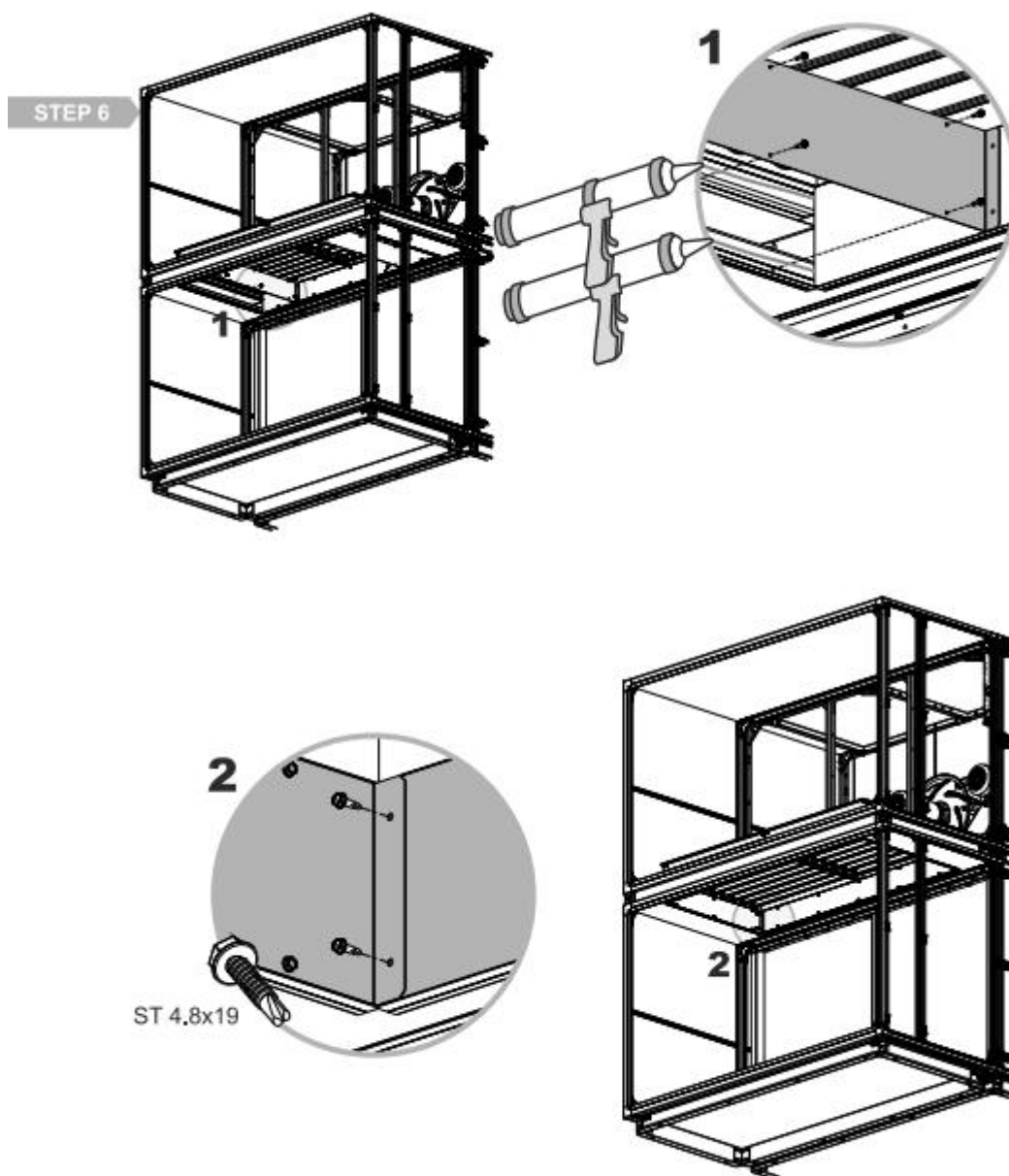

SECTION ASSEMBLY STEP 7

STEP 7

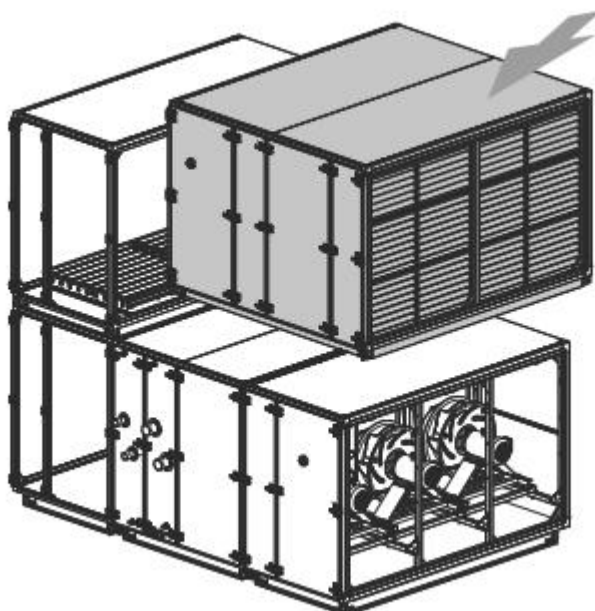

STEP 1-2, 4

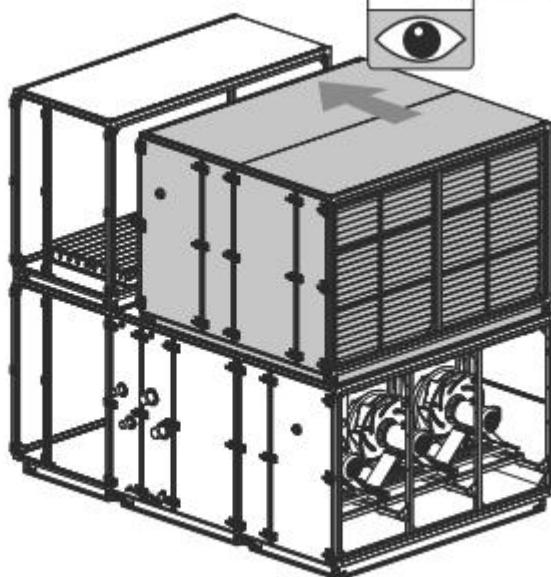

4.6 ROOF ASSEMBLY

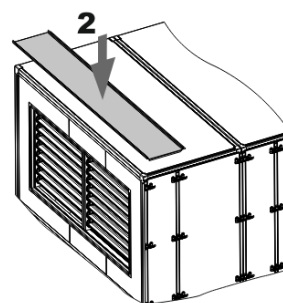
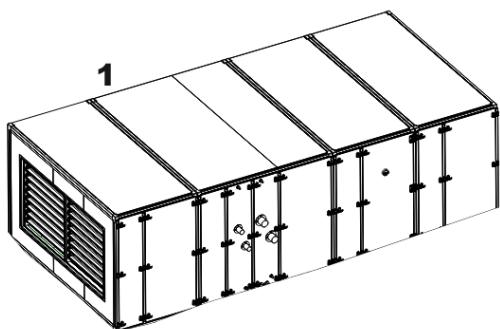

IX.D.

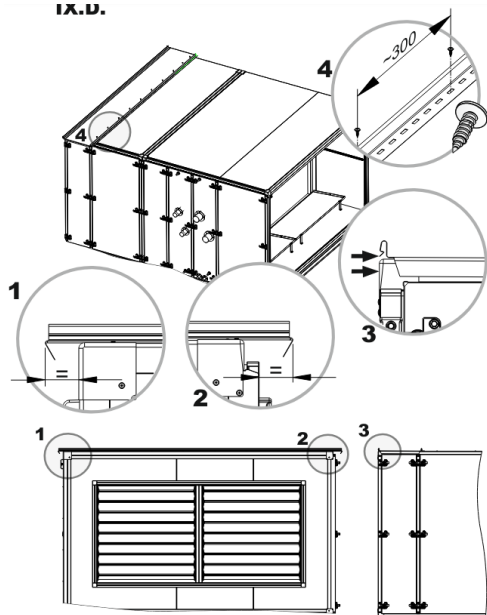

IX.D.

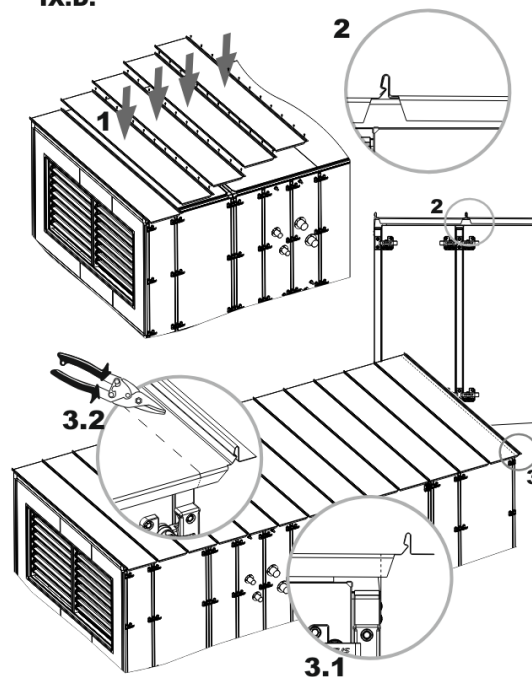

IX.D.

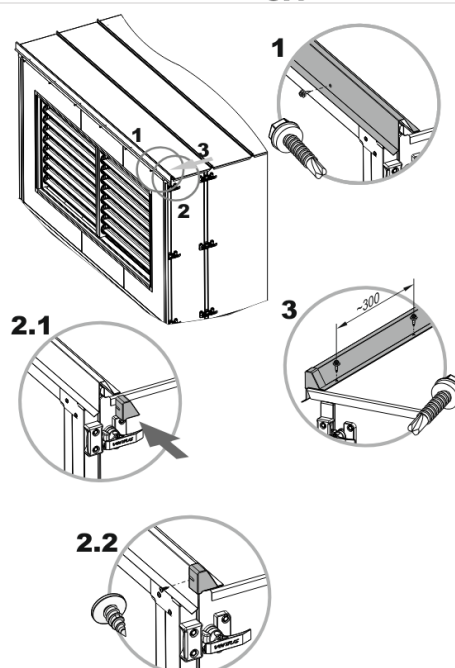
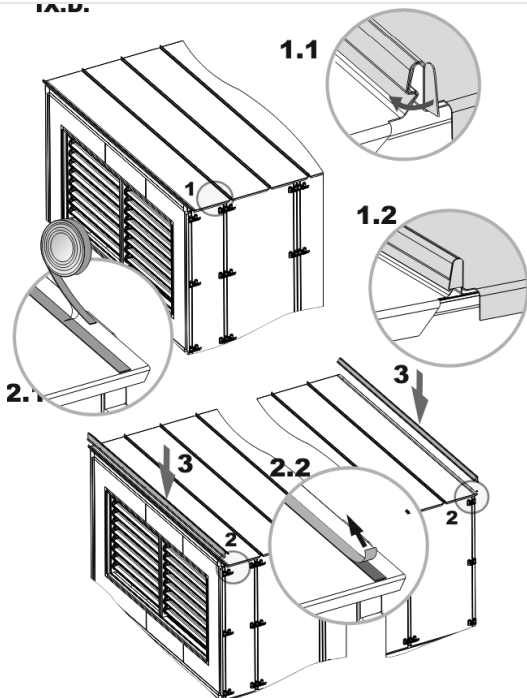

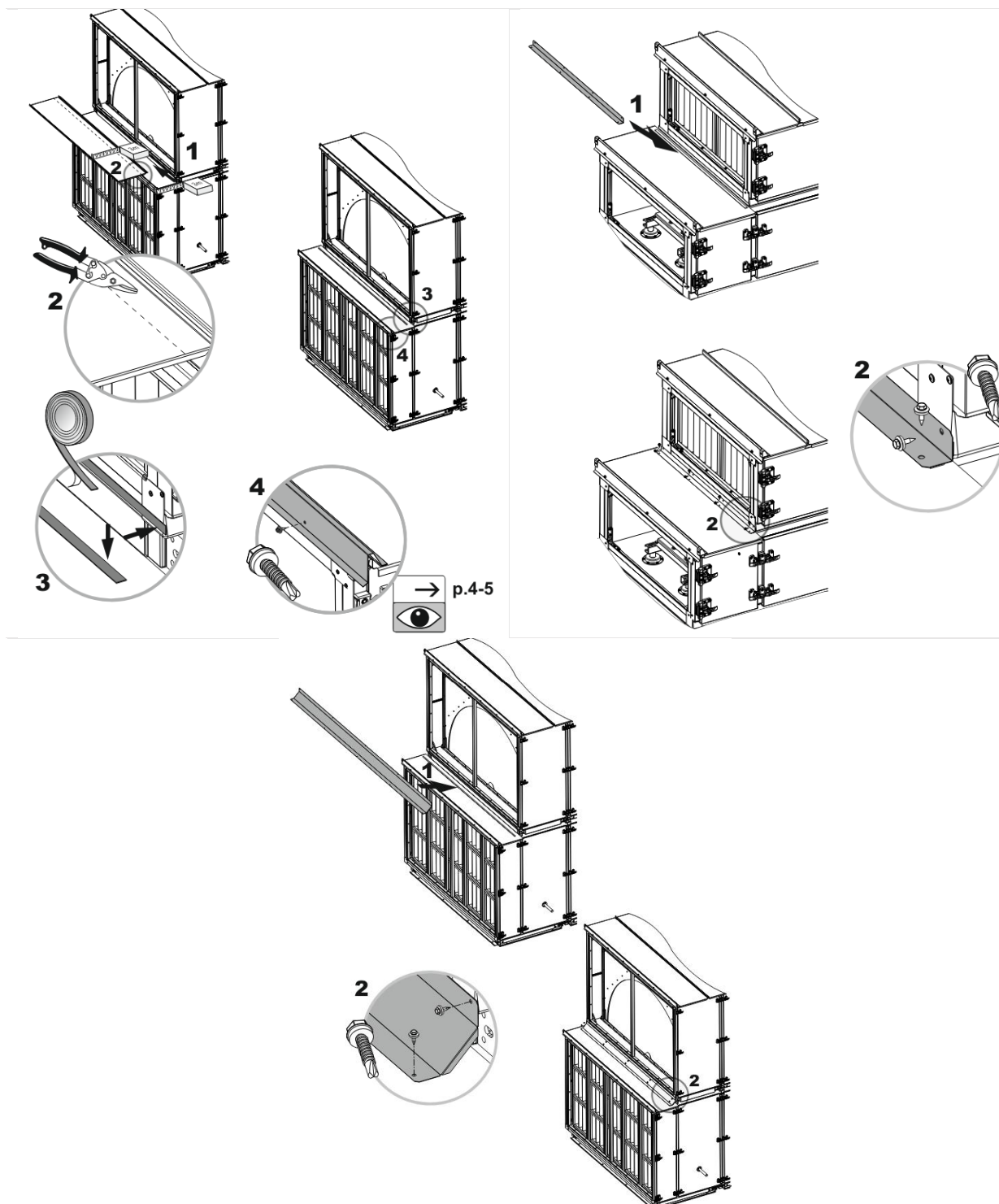

A dedicated "Roof assembly / Roof installation" manual is available at [www.vtsgroup.com](https://vtsgroup.com/files/document-files/168/Montaz_dachu.pdf) (https://vtsgroup.com/files/document-files/168/Montaz_dachu.pdf).

4.7 INSTALLATION OF THE AIR DAMPER ACTUATOR COVER

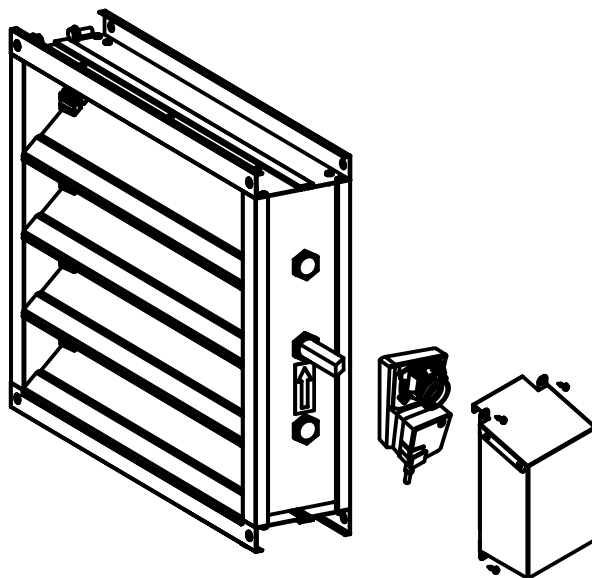

5 CONNECTION OF RELATED INSTALLATIONS

5.1 CONNECTION OF WATER HEATERS AND COOLERS



- ! The operation of the water exchanger requires its connection to the system of process heat or chilled water, depending on the designed function of this exchanger.
- ! Exchangers must be protected from freezing (if there is such a risk).
- ! Connection of heat exchangers should be carried out in a manner that does not cause stresses that may result in mechanical damage or leaks. The weight of the pipes and thermal stress must not be transferred to the exchanger connections.
- ! Power cables should be routed in such a way as to avoid collision with other sections of the air handling unit and other installations.
- ! It must be possible to easily disconnect the exchangers from the process heat system for maintenance and service.
- ! Use compensation at the inlet and outlet of joints, to compensate for linear expansion of pipes.
- ! Hydraulic lines must not be routed over electrical lines.

QUALITY REQUIREMENTS FOR THE SUPPLY MEDIUM WATER EXCHANGERS

- ! Oil and grease < 1 mg/l ! pH at (+25)°C 8-9.
- ! Oxygen < 0.1 mg/L (as low as possible).
- ! Minimum cooler temperature (+3) °C.
- ! Maximum operating temperature (+130)°C.
- ! Maximum working pressure of 16 bar (test pressure of 21bar).
- ! At negative return temperatures, the factor should use an additive that lowers the freezing point, such as glycol (up to a maximum of 50% content in the mixture).
- ! Water hardness not greater than:
 - normal concentration = 4.101 [mval/l] [mval/dm³]
 - molar concentration = 2.051 [mmol/l] [mmol/dm³].
 - Ca⁺²/l = 82.189 [mg Ca⁺²/l] [mg Ca⁺²/dm³].
 - CaCO₃ = 205.25 [mg CaCO₃/l] [mg CaCO₃/dm³] (ppm)
 - French degrees = 20.525 [°f] [°TH].
 - English degrees = 14,400 [°e] [grain CaCO₃/gal(UK)].
 - US = 11,990 [grain CaCO₃/gal(US)].
 - CaO = 115,000 [mg CaO/l] [mg CaO/dm³].
 - German degrees = 11,500 [°n] [°dH].

PROTECTION OF SCREWED CONNECTIONS OF THE WATER EXCHANGER

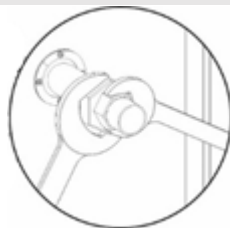

- ! When installing a supply system for exchangers equipped with bolted connections, the exchanger connector should be relieved with an additional wrench.



GENERAL PRINCIPLE OF SUPPLYING WATER EXCHANGERS

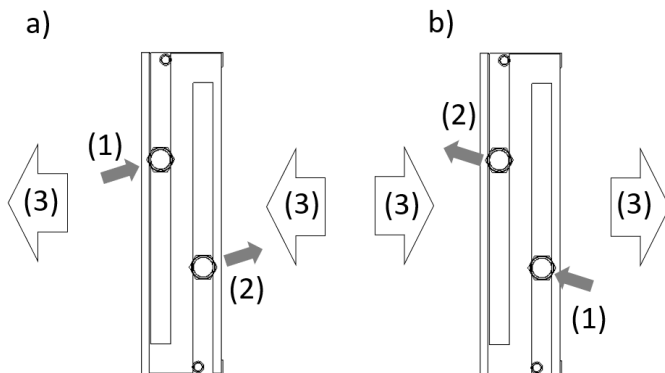

- a) Left-hand execution
- b) Right-hand execution
- (1) Supply of the exchanger with heating/cooling medium
- (2) Return from the factor exchanger
- (3) Direction of air flow in the air handling unit

- ! The exchanger's refrigerant supply and return connections should be configured so that the exchanger operates in countercurrent mode. The parallel mode of operation of the exchanger results in a lower average temperature difference, reducing its operating efficiency.
- ! In VVS400-VVS650 size units, the water heat exchanger is divided into two sections. Each section must be fed evenly with the same amount and temperature of water (parallel connection).
- ! It is not allowed to have connection in series.

PRINCIPLE OF CONNECTING VALVES TO WATER EXCHANGERS

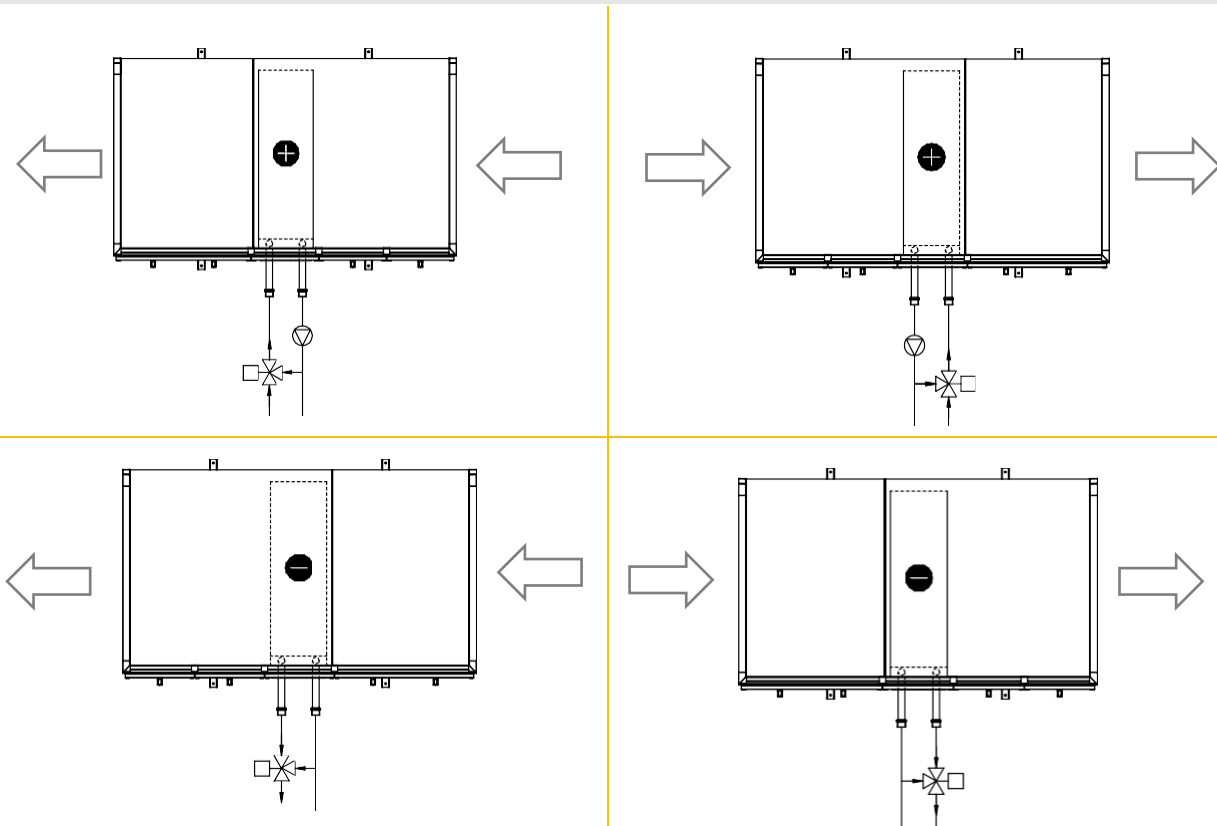

NOMINAL DIAMETER OF CONNECTIONS DN [mm].	WATER EXCHANGERS	
	COLLECTOR CONNECTION MATERIAL	METHOD OF CONNECTION
20	Brass	R 3/4" thread
25	Brass	R 1" thread
32	Brass	Thread 1 1/4"
50	Steel	2" thread
80	Steel	R-thread 3"

EXAMPLE CONNECTION OF EXCHANGERS IN A HEAT RECOVERY SYSTEM WITH AN INTERMEDIATE MEDIUM (RUN-AROUND COILS)

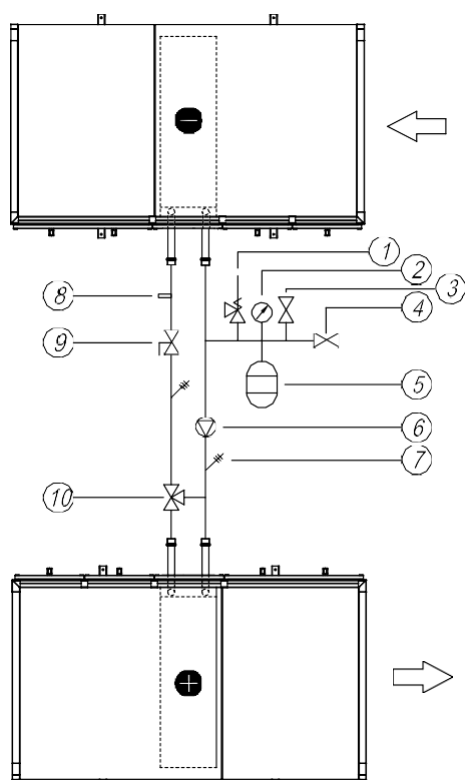

1	Safety valve
2	Pressure gauge
3	Vent valve
4	Supply valve
5	Collection vessel
6	Circulation pump
7	Thermometer
8	Connector for temperature sensor
9	Compensation valve
10	Check valve

5.2 CONNECTION OF DX (DIRECT EXPANSION) EXCHANGERS

- ! Connection of the DX exchanger must be carried out by a qualified refrigeration installer in accordance with the rules and regulations applicable to freon refrigeration equipment (F-gas qualification).
- ! The DX heat exchanger is designed to operate with R410A or R32 refrigerant (not supplied) in a system with an expansion valve.
- ! To ensure proper operation of DX coolers or heaters, these exchangers should be connected to the DX system with a condensing/cooling unit in accordance with all applicable regulations, rules and best practices.
- ! Maximum operating pressure 42 bar (for 5/16" exchangers)
- ! Operating or stopping at sub-zero temperatures requires a protection system and a defrosting system. Protect the coil from frost buildup on its surface
- ! The exchanger must not be allowed to freeze or frost over completely.
- ! For units equipped with a Freon installation - before installing the unit, check the applicable regulations related to the obligations of the installer, owner (operator) of the heat pump or DX installation (see the F-Gas Law).
- ! Do not release refrigerant into the atmosphere! If the addition or extraction of refrigerant is required, then the service technician performing this operation must follow all local regulations.
- ! The owner of the heat pump or the owner (operator) of the DX installation is required to establish a Product Card, in which all inspections, repairs or modifications to the device are recorded.

PRINCIPLE OF FEEDING DX EXCHANGERS (COOLERS, HEATERS)

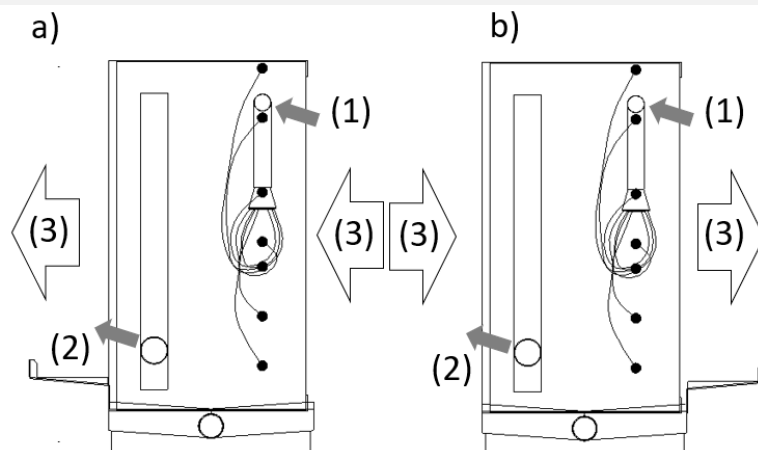

- a) Left-hand execution
- b) Right-hand execution
- (1) Supply of the exchanger (liquid line - supply of the medium to the manifold)
- (2) Suction line (vapor line - return of the refrigerant to the compressor)
- (3) Direction of air flow in the air handling unit

- ! DX heat exchangers have copper stubs suitable for brazing.
- ! DX heat exchangers have capillary connections. When brazing or welding pipes, avoid exposing pipe components to high temperatures when making capillary connections and protect the valve closest to the connection to be made with a wet cloth.

5.3 CONDENSATE DRAINAGE

Moisture can condense on the surfaces of the air coolers and heat recovery exchanger from the air. The condensed moisture (condensate) flows into the drip tray located below these functions. The installer is required to connect the drip trays to the drainage system, taking into account the use of traps. The condensate drainage is led outside the air handling unit Casing. The outlets are located in the condensate trays of the coolers (the diameter of the drainpipe is Ø 32 mm).

Counterflow heat exchanger units in sizes VVS021-VVS055 are equipped with a plastic extension tube to be installed at the drip tray connection to drain condensate outside the unit.

U-traps should be connected to the drain stubs to drain, at different pressure values in the section and ambient pressure, the condensed water on the exchangers.

For proper drainage of condensate from the air handling unit, it is necessary to install a U-TRAP on the drain stub of the sump, in the sections of the air handling unit where there is negative pressure. Drain traps are not included in the scope of delivery. It is not necessary to use drain traps in sections where there is positive pressure, however, to minimize air blowing, a trap can be used on the condensate drainage system.

The usable height of u-traps "H" depends on the value of the pressure difference between the pressure in the section of the air handling unit from which condensate is discharged during operation and the ambient pressure. The dimension "H" calculated in mm must be greater than the pressure difference expressed in mm H₂O.

It is permissible to connect the u-traps of different sections with a single outlet manifold, provided that the manifold has a connection to the environment (venting). Before commissioning the air handling unit, the traps should be flooded with water. In a cold environment, the water drain should be insulated and, if necessary, a suitable heating system should be used.



- ! For proper operation of the air handling unit, it is required to install u-traps for baths located on the suction side of the fan (on negative pressure).
- ! It is recommended to use u-traps for tubs located on the discharge side of the fan (on positive pressure).
- ! Ball valves cannot be used on the discharge side of the fan.
- ! It is not possible to combine different condensate drains into one trap.
- ! Before starting the air conditioning unit, fill the U-TRAP with water.
- ! If the environment is cold, insulate the drainage lines.
- ! If the condensate is in danger of freezing, use a suitable system for heating it.

CONDENSATE DRAINAGE - U-TRAP CONNECTION

$p < p_{\text{atmospheric}}$

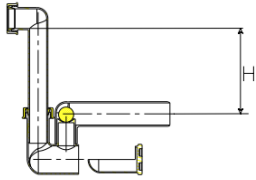

$p > p_{\text{atmospheric}}$

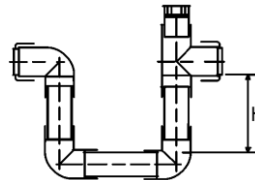

H [mm] = total fan backflow in mm H₂O

$$H \text{ [mm]} = Dp \text{ [Pa]} * 0.1$$

Dp [Pa] - ventilator airflow in pascals

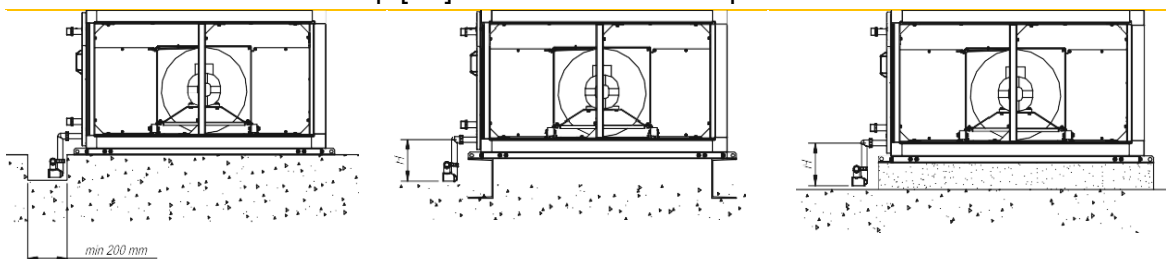

5.4 CONNECTION OF EVAPORATIVE HUMIDIFIER

VVS021-VVS650 air handling units can be equipped with a evaporative humidifier. The evaporative humidifier works on the principle of moisture transfer by evaporation of water from the sprinkled bed into the flowing air. Humidification of this type is characterized by high efficiency and reliability. Depending on the size of the air handling unit, the humidifiers used will operate on tap (mains water) (VVS021-VVS055) and circulating water (VVS075-VVS650).

COMPOUND HUMIDIFIER:

- (a) WITH DIRECT POWER (VVS021-VVS055);
 (b) WITH CURRENT POWER (VVS075-VVS650).

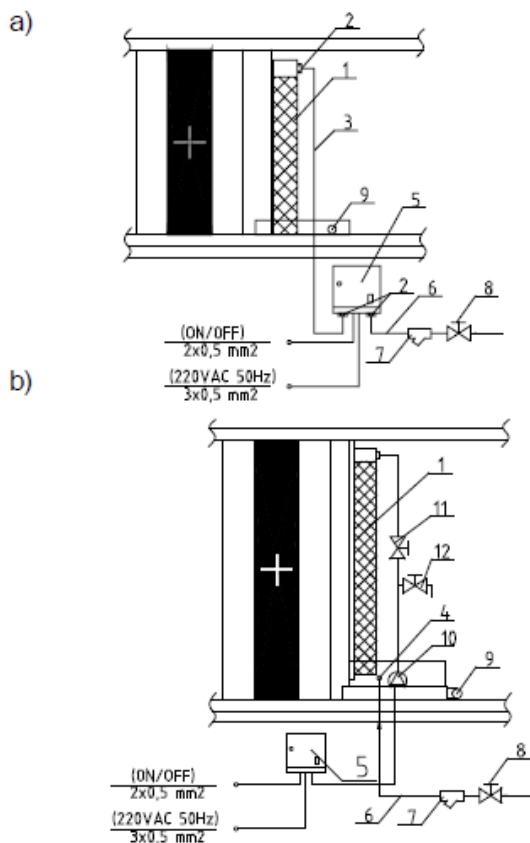

1	Humidifier cartridge
2	Compression fitting Ø10
3	Supply of humidifier cartridge (high-pressure nylon hose Ø10mm)
4	Supply spigot DN15
5	Humidifier controller
6	Supply pipe
7	Water filter
8	Ball shut-off valve
9	Drain stub DN25
10	Circulation pump
11	Check valve
12	Bleed valve

The connection to the water supply and drainage should be made without mechanical stress that could cause mechanical damage or leakage. Each humidifier unit shall be assembled with the necessary external piping and checked for watertightness before delivery.

The supply system should ensure the quality of "tap" water without excessive deposition of dirt and other particles that could lead to dust accumulation on the surface of the hydration pads.

Evaporative humidifiers do not require special water treatment before feeding the device. Nevertheless, a ball shut-off valve and a filter-type settling tank (not included in the scope of supply) must be installed on the supply pipe.

Air handling units with humidifiers are supplied with a control box for installation outside the air handling unit. The installation location of the control box must be protected from the weather and provide a temperature range of (+5)° C to (+40) C°

The humidifier with direct supply should be connected to the cabinet with a hose and compression fittings Φ 10 (supplied with the humidifier). In the control panel, a hole should be made for the passage of

the pipe supplying the humidifier cartridge. Secure the cable with glands. The water supply to the control cabinet is connected in a similar way.

If necessary, the pipe between the humidifier and the control cabinet can be extended, but not more than 5 m.

In the case of a humidifier with circulating water VVS075-VVS650, the supply water should be connected to the connection pipe (DN15) leading outside the inspection panel.

TYPES OF SUPPLY AND DRAINAGE CONNECTION		
	VVS021-VVS055	VVS075-VVS650
Humidifier type	With direct power supply	With circulation
Power connection	Galvanized pipe with DN15 thread	Ø10mm nylon high-pressure hose
Connecting the discharge	Galvanized pipe with thread DN25	Galvanized pipe with thread DN25
Performance side	Universal	Right or Left

PARAMETERS OF OPERATION OF HUMIDIFIERS	
PARAMETER	PARAMETER LIMIT
Maximum air speed VVS021-VVS055	3.0m/s
Maximum air speed VVS75-VVS650	4.0m/s
Water temperature	5..40 °C
Water pressure	0.15..0.75MPa
Water quality	"Tap water"
Ambient temperature for the controller	5..50 °C
Max. ambient humidity for the controller	90%rH

WATER PARAMETERS FOR HUMIDIFIER OPERATION	
PARAMETER	CONTENT IN FEED WATER
Temperature	< 20 °C
Aluminum	< 200 µg/l
Amon <	< 0.50 mg/l
Calcium	< 300 mg/l
Chloride	< 300 mg/l
Copper	< 1 mg/l
Conductivity	< 2000 µS/cm at 20°C (
pH 6.5 to 9.5	6.5 to 9.5
Iron <0.5 mg / l	< 0.5 mg/l
Manganese <0.1 mg / l	< 0.1 mg/l
Fragrance	Acceptable to users
Sulfate	< 250 mg/l
Silicate	< 150 mg/l
Trihalomethane	< 100 µg/l
Number of colonies at 22 ° C	< 100/ml
Coliform bacteria	0/100 ml
Legionella bacteria	< 50 cfu/1000 ml
Pseudomonas species	0/250 ml

The direct-powered humidifier is a simple and compact design containing little space in the control panel. The humidifier cartridge is supplied with water from the top, and the excess water is collected in a tub and discharged outside the air handling unit. The amount of water is controlled by a solenoid valve installed in the control cabinet (supplied with the humidifier).





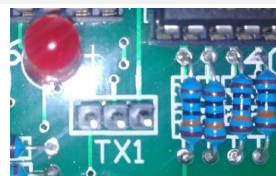
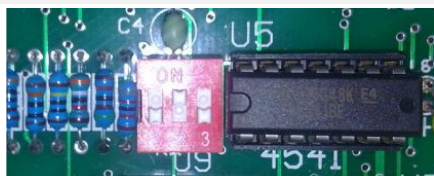

The recirculating type humidifier cartridge is powered by a circulation pump located in the water tank. Excess water flows into the tank and is reused to feed the humidifier cartridge. The evaporation of water causes the water level in the tank to drop, which is regulated by a float valve. A side effect of water evaporation is an increase in impurities in the tank. This process is controlled by two valves, one of which cuts off the water supply and the other opens the water drain to completely empty the tank. After this operation, the valves are switched and the humidifier returns to normal operation with clean water.

For water drainage, the same guidelines apply as for the exchanger drip trays described in the "Condensate drainage" section.

SET THE TIME (PERIOD) FOR EMPTYING THE WATER HUMIDIFIER TRAY.

A SPECIAL SLIDE SWITCH AND A PIN SWITCH (TX1) ARE PLACED IN THE CONTROL CABINET:



SUWAKE POSITION.	TRAY EMPTYING PERIOD (TEST) [MIN.]		TRAY EMPTYING PERIOD [HOURS]	
	TX1		TX1	
	2.2		24.2	
	4.9		83.6	
	6.4		109	
	10		171.5	
	2.8		47.4	
	3.9		66.8	
	3.3		56.2	

! To make sure that the water in the tray is clean, it is recommended to drain and rinse it once every 24 hours.

6 POWER AND CONTROL INSTALLATIONS



- ! Electrical connections of control panel equipment elements should be made by persons with appropriate qualifications and authorizations and made in a manner consistent with in accordance with the relevant standards and regulations in force in the country where the device is installed.
- ! Cross-sections and types of cables (e.g., shielded cable), supplying power to individual functional components, should be selected based on rated current and peculiar operating conditions (e.g., ambient temperature, wiring method, distance from power source).
- ! Electric heaters and water pumps for primary and secondary heaters should be supplied from an external switchgear (outside the supply).
- ! Before connecting the power supply, check the compatibility of the voltage and frequency of the supply network with the data on the equipment nameplates. Permissible deviations of the value of the supply voltage and its frequency in relation to those specified on the nameplate are $\pm 5\%$. If there are inconsistencies, the devices should not be connected.

6.1 FAN ELECTRIC MOTOR

6.1.1 AHU UNITS WITH EC MOTOR

The air handling units are equipped with fans with modern and efficient EC motors. The IP degree of protection of the motors with the controller is 44. Proprietary electronics protect them against overload, failure, phase loss, under and over voltage and phase overvoltage.

The motor can be started using digital commands, bus commands, references or a local start command when the drive is connected to an AC power line.

With motors up to 0.75kW, cables terminated with a MOLEX plug are brought out.

MOLEX CONNECTING PLUG EC MOTOR BOX 0,75kW

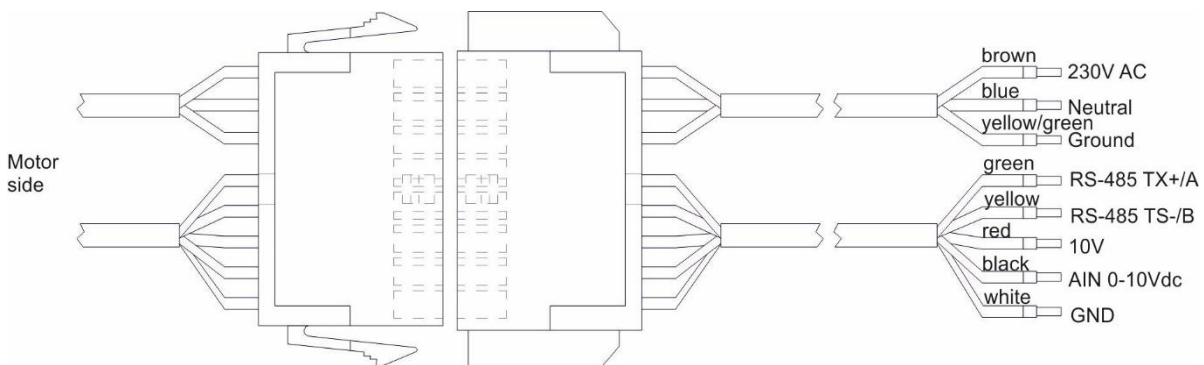

Color coding: brown - 230V AC , blue - neutral , green/yellow - grounding
green - RS485 TX+/A, yellow- RS485 TX-/B, red - 10V DC output, black - 0-10V DC AIN input, white - GND

CONNECTING EC 1650W and 3250W MOTORS.

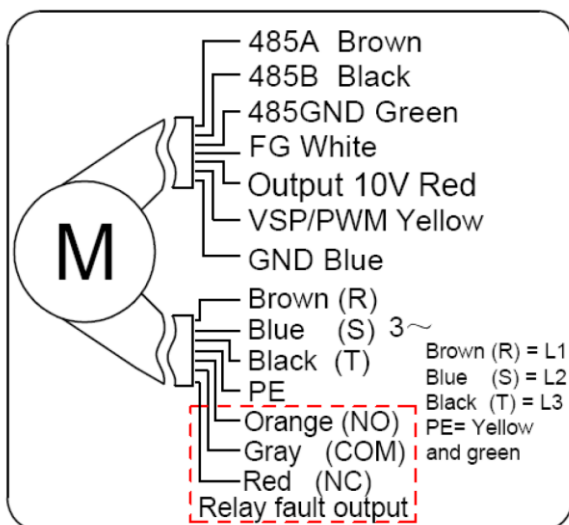

6.1.2 AIR HANDLING UNITS WITH AC MOTOR OF 0.75KW AND ABOVE

See the dedicated manual.

The fan motors are suitable for operation in dusty and humid environments (IP55), and their insulation (class F) is designed to work with a frequency converter. No additional motor protection measures are required in relation to the conditions in the fan sections.

Motors with their own cooling system and fans mounted directly on the shaft are standard in the units. Power wiring must be fed to the fan motor through rubber grommets located on the rear panel of the air handling unit casing.



! It is not permissible to run power cables through the inspection panel

6.1.2.1 BELT DRIVE OF THE FAN

Belt drive fan motors are supplied with voltage 3~ 400V/50Hz. The connection should be made through overload and short-circuit protection suitable for the rated current of the motor type used.



! AC motors of fans up to 4 kW can be started directly. AC motors of 5.5 kW and above, should be started in the "star-delta" starting system.

6.1.2.2 DIRECT DRIVE FAN

Direct drive EC motors are powered by AC single-phase voltage 1~ 230V , EC motors with power above 1.5 kW are powered by AC three-phase voltage 3~ 400V . AC motors up to 2.2 kW are powered by 3~ 230V single-phase 1~230V AC inverters. Motors with higher powers are supplied with voltage 3~ 400V when working with frequency inverters supplied with three-phase voltage 3~ 400V.



! Before connecting the fan unit, carefully check the power supply and output ratings of the drive.

The connection should be made via short-circuit protection suitable for the type of frequency converter used. When using EC motors or AC motors powered by a converter, it is not necessary to connect PTC motor protection.

When powered by an inverter, there is no need to connect PTC protection for the motor. Overload protection is implemented on the frequency converter by activating certain parameters and entering motor ratings according to the instructions provided
With a frequency converter.



! In fan sections equipped with more than one fan, synchronous operation of fans should be ensured. The control of the fans should be made so that their starting, speed change and stopping occur simultaneously. If one of the fans fails and stops, the fan section does not perform its function and should be shut down.



! A limit switch is installed in the inspection door of the fan section, causing the fans to stop in case of unauthorized opening of the door. The switch should be connected to the inverter in accordance with the diagram attached in a separate manual.

When powering a motor from a frequency converter, high-frequency currents or voltage harmonics in the motor's power cables can cause electromagnetic interference. The connection between the frequency converter and the motor must be made with shielded cables, according to the guidelines in the User's Manual (DTR) of the frequency converter.

Before the first commissioning and after a prolonged period of storage or standstill, the insulation resistance between the casing and the windings should be measured with direct current. The minimum insulation resistance value for a new, cleaned or repaired winding should be 10 MΩ with respect to the grounded protective conductor.

CONNECTING THE POWER CABLES OF SINGLE-SPEED MOTORS TO THE TERMINALS IN THE TERMINAL BOX.

INDICATION ON THE MOTOR NAMEPLATE	MOTOR POWER FROM THE NETWORK 3~ 400V/50HZ	POWERING THE MOTOR VIA A FREQUENCY CONVERTER	
		POWER SUPPLY OF THE CONVERTER FROM THE NETWORK 3~ 400V/50HZ	POWER SUPPLY OF THE CONVERTER FROM THE NETWORK 1~ 230V/50HZ
230V/400V D/Y	<p>Star connection diagram for a 230V/400V D/Y motor. The motor terminals are labeled WC, UC, and VC at the top, and U1, V1, and W1 at the bottom. The power supply terminals are labeled L1, L2, and L3. The diagram shows a star connection with a 3x400V supply.</p>	<p>Star connection diagram for a 230V/400V D/Y motor with a frequency converter. The motor terminals are labeled WC, UC, and VC at the top, and U1, V1, and W1 at the bottom. The power supply terminals are labeled L1, L2, and L3. The diagram shows a star connection with a 3x400V supply.</p>	<p>Delta connection diagram for a 230V/400V D/Y motor with a frequency converter. The motor terminals are labeled WC, UC, and VC at the top, and U1, V1, and W1 at the bottom. The power supply terminals are labeled L1, L2, and L3. The diagram shows a delta connection with a 3x230V supply.</p>
	<p>Delta connection diagram for a 400V/690V D/Y motor. The motor terminals are labeled WC, UC, and VC at the top, and U1, V1, and W1 at the bottom. The power supply terminals are labeled L1, L2, and L3. The diagram shows a delta connection with a 3x400V supply.</p>	<p>Delta connection diagram for a 400V/690V D/Y motor with a frequency converter. The motor terminals are labeled WC, UC, and VC at the top, and U1, V1, and W1 at the bottom. The power supply terminals are labeled L1, L2, and L3. The diagram shows a delta connection with a 3x400V supply.</p>	<p>A large 'X' mark indicating that this configuration is incorrect.</p>

6.2 ELECTRIC HEATER



- ! Connection of power supply to the heater with control module should be made directly in the heater section in accordance with the guidelines contained in the **User's Manual (Installation, Operation and Maintenance Manual - IOMM of the electric heater and control module)**.
- ! The supply wires to the electric heater should be routed through the fixed panel at the rear of the air handling unit. If the wires are routed through the inspection panel on the service side, they should be routed to ensure that the section can be opened for inspection or service.
- ! The connection of the heater should be implemented in a way that prevents the possibility of switching on the heater without the fan on. In addition, if the fan is interrupted, the power supply to the heater must be disconnected
- ! The connection of the heater should be made in such a way that it is not possible for the heater to switch on when the fan is not on - for this purpose there are factory-mounted, serially connected protections in the form of a thermostat and pressure switch, preventing the heater from switching on if the temperature and airflow conditions are not met.
- ! If the fan is stopped, it is absolutely necessary to turn off the power supply to the heater.



See instructions at www.vtsgroup.com :

- ! **Installation, Operation and Maintenance Manual - Electric Heater supply and control system/ Electric heater supply and control system Technical and operating documentation,**
- ! **Operation and Maintenance manual - Electric Heaters - Power Slices / Electric heaters - slices Technical and operating documentation.**

The electric heater is an optional accessory and consists of heating elements (heaters), connection terminal, control automation (SCCR) and protection against excessive temperature rise.

The heaters are Cr-Ni-Fe heating wires of 6kW/400V. They are connected in heating patches (heating sections). The heater can consist of: 1, 2 or 3 heating slices.

The electric heaters can be supplied in two power variants - low power, which is suitable for AHUs with relatively low heating requirements and high power, which includes AHU cases for facilities with higher heating requirements. These types differ primarily in the types of electrical connections of individual heaters in the heater unit (star connection for low power or delta connection for high power).

Appropriate connection of heaters between each other is made at the stage of heater production - from the installer is required only to connect the power and control wires - it is not allowed to modify the connections of the heater system in relation to the factory configuration.

Modulating the Supply Voltage Depending on the Heating Power Demand (First Heating Slice).



The first slice is controlled smoothly 0-10V, each other (ON/OFF) ON-OFF.

Each time a regulated slice reaches full power, the demand is transferred to the next slice, which starts operating at full capacity. Any additional heating power will be realized by smoothly increasing the regulated heating power of the modulating slice.

ELECTRICAL INSTALLATION DETAILS

Type of network	TN
Rated supply voltage	3x400V AC
Rated insulation voltage	400V
Rated withstand surge voltage	2500V
Rated short-circuit current I _{cw} for individual circuits - the effective value of the periodic component withstood for 1s, i.e., the short-circuit current expected at the switching voltage	6kA
Rated short-circuit current	6kA
Simultaneity factor	0,8
Rated frequency	50 Hz
Degree of protection	IP00
Permissible operating temperature	0 °C ÷ (+50) °C
Supply voltage of control circuits	24V DC
Type of network	TN
Rated supply voltage	3~400V AC
Rated insulation voltage	400V
Rated withstand surge voltage	2500V

The type of conductors used for each heater function is shown in the table below. The conductor cross-section and its protection should be selected based on the information indicated in the table above.

Types of wires to connect electric heaters			
Application of the cable	Rated voltage	Type	Operating temperature
Power supply for electric heaters	3~400V AC	multicore, copper conductor - stranded wire	(-30) C° ÷ (+60) C°
Power supply for the control system	1~230V AC	multicore, copper conductor - stranded wire	(-30) C° ÷ (+60) C°
Control of the heater automation system	24V DC	multicore, copper conductor - stranded wire	(-30) C° ÷ (+60) C°

6.2.1 THERMAL SWITCH (THERMIC)

The functionality of the thermostat is based on the properties of the bimetallic element - it causes the contacts of the heater control circuit to open when the air temperature near the thermostat is 65°C. After an emergency shutdown, the heater automatically turns on when the air temperature drops by 20°C. After an intentional or emergency (caused by overheating) shutdown, the supply fan must run for a certain period of time (0.5-5 min), so that the heater heaters reach normal temperature.

!

! The thermal switch is an integrated, factory-installed component of each heater patch - it requires no additional installation or electrical connection by the installer.

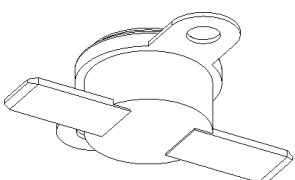
THERMAL SWITCH- CHARACTERISTICS		
Thermal switch	Connecting	Comments
	Function	heater protection against overheating (temperature control of heating elements)
	Construction	<ul style="list-style-type: none"> metal casing two screw terminals bimetallic element with NC contact function
	Rated operating voltage	30V DC
	Output signal type	Voltage-free (switching contact)
	Activation temperature	(+65) °C
	Temperature hysteresis	17 °C

6.2.2 DIFFERENTIAL PRESSURE SWITCH

The differential pressure switch is another safety element, in addition to the thermostat, that prevents the heater from operating in prohibited conditions. It prevents the heater from switching on when the pressure generated by the fan units on the supply side of the air handling unit is insufficient to ensure safe operation of the heating elements.



! The pressure switch is a factory-installed component and electrically connected - **the connection of pressure switch pressure hoses should be made at the site according to the following recommendations:**

- one of the wires should be led to atmospheric pressure - if the switchgear is mounted on a duct (outside), the cable does not need to be connected - the switchgear is at atmospheric pressure,
- The second of the wires should be connected at the positive or negative pressure in the control panel or in the duct (before or after the supply motor),
- it is permissible to move the pressure switch outside the switchboard (in the duct version of the heater) to avoid the need to run long measuring tubes - the recommended position of the pressure switch - horizontal, with a vertical position the reading is overstated by 11 Pa compared to the actual one.



! The switching threshold of the pressure switch is 20 Pa. After connecting to the AHU, check that the pressure switch operates correctly for the smallest available capacity of the air handling unit.

If there is no detected differential pressure, change the place of connection of the second pressure hose to the system.

! In the opposite case - **when for a given pressure switch setting the pressure difference is detected even when the air handling unit is switched off** (allowing the operation of the heater despite the lack of operation of the fans), the setting should be gradually increased until correct operation is achieved - its sign is the lack of operation of the electric heater despite the occurrence of control signals, if the pressure switch does not detect the pressure difference between the measuring channels - permission should be given only after starting the fans.

! **After the pressure switch is fully connected, the heater shutdown test should be performed.** To do this, force the control of the electric heater manually (e.g., providing control signals of the heater from the controller) and at the same time stop the control of the fans. The pressure switch should prevent the operation of the electric heater (this will be evident, for example, by disconnecting the contactors in the switchboard).

DIFFERENTIAL PRESSURE SWITCH - CHARACTERISTICS

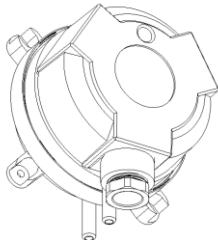
Differential pressure switch	Connecting	Comments
	Function	protecting the heater from overheating (controlling the pressure difference between the supply duct and atmospheric pressure)
	Construction	<ul style="list-style-type: none"> plastic casing, two screw terminals, membrane connected to mechanical module
	Rated operating voltage	30 V DC
	Output signal type	Voltage-free (switching contact)
	Measuring range	20-300 Pa

6.2.3 CONNECTION OF AUTOMATION OF ELECTRIC HEATERS

EXAMPLE CONNECTION OF ELECTRIC HEATER WITH SWITCHBOARD (1X18KW)

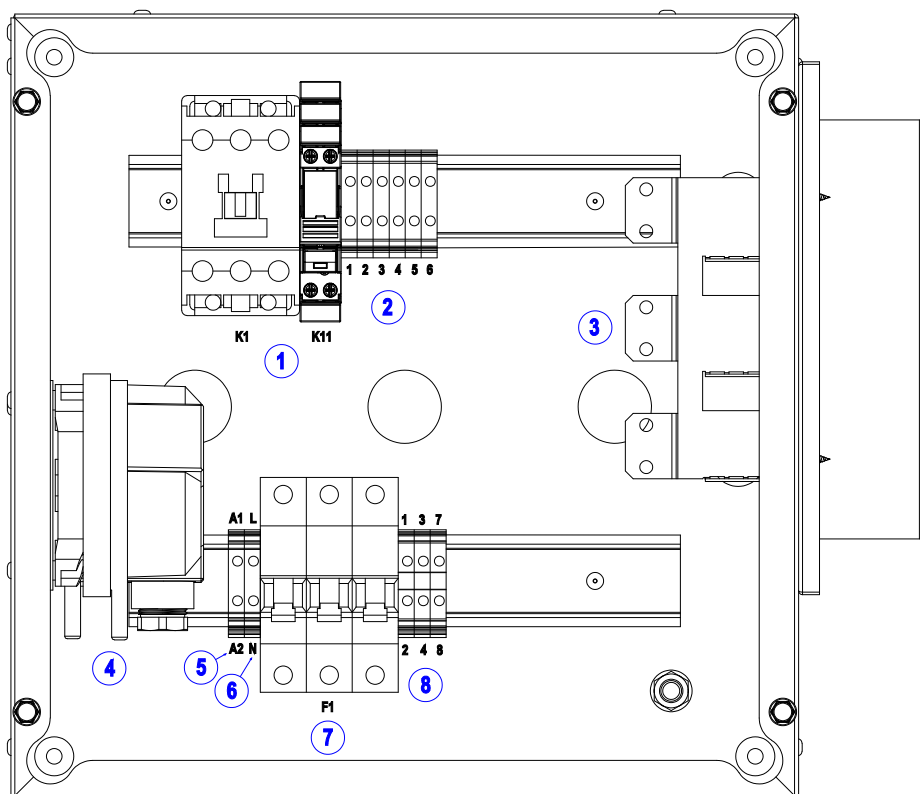

Designation	Description	Connecting	Comments
1	relays / contactors	factory	-
2	heater terminals	factory	-
3	heaters	factory	-
4	pressure switch	factory / <u>installer</u>	<u>the connection of the pressure switch tubes is made by the user</u>
5	signal terminals - alarm	<u>on site / installer</u>	-
6	power terminals 1f	<u>on site / installer</u>	-
7	overcurrent circuit breakers	<u>on site / installer</u>	-
8	signal terminals - control	<u>on site / installer</u>	-

The view of the switchgear shown is intended to illustrate the arrangement of components inside their casing. Please note that they are for illustrative purposes only - when making electrical connections, always follow the electrical diagrams

6.3 ROTARY HEAT EXCHANGER (REGENERATIVE HEAT EXCHANGER)

The rotary exchanger is driven by a drive unit consisting of a gearmotor (squirrel cage motor + worm gear) and a frequency converter. The control system is adapted to connect a standard 0-10V control signal and to operate in an RS485 network using the Modbus protocol. The frequency converter is powered by single-phase AC voltage 1~ 230V/50Hz. All electrical connections and configuration of the rotary exchanger drive unit should be made in accordance with the guidelines contained in the "**Manual for rotary exchanger drive units**".



See instructions at www.vtsgroup.com :

! **Installation, Operation and Maintenance Manual Vts Ec Motor Drive / Technical Terms and Conditions for Drives with EC Motors for VTS Units.**

6.4 EVAPORATIVE HUMIDIFIER



- ! Humidifiers are equipped with control cabinets that control the operation of humidifier components and ensure proper functionality and safety of operation (e.g., protection against dry running of the pump).
- ! Control cabinets do not control humidity and do not regulate humidification. The control signal (On/Off) must be fed to the cabinet from another, external controller.

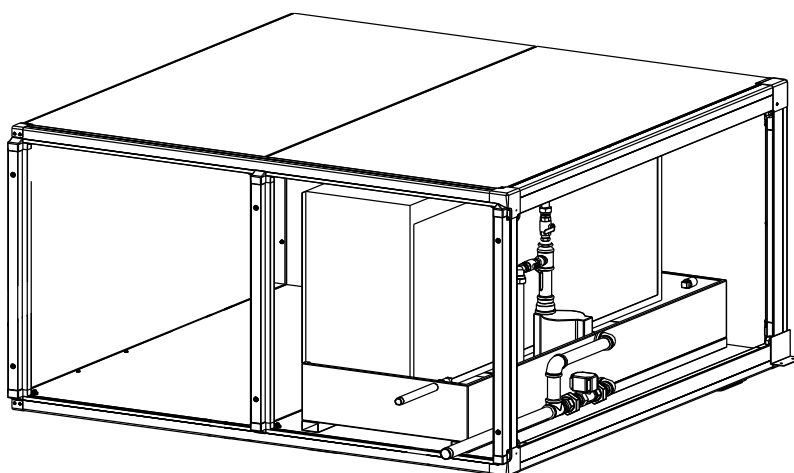

WORKING CONDITIONS OF THE HUMIDIFIER

Ambient conditions of the control system	+5°C ÷ +50°C Humidity < 90%
Environmental conditions of the humidifying cartridge	+5°C ÷ +90°C
Maximum air speed	< 3 m/s
Humidifier feed water temperature	+5°C ÷ 40°C
Water inlet pressure	0.15 MPa ÷ 0.75 MPa

WIRING DIAGRAM OF THE HUMIDIFIER WITH DIRECT WATER SUPPLY

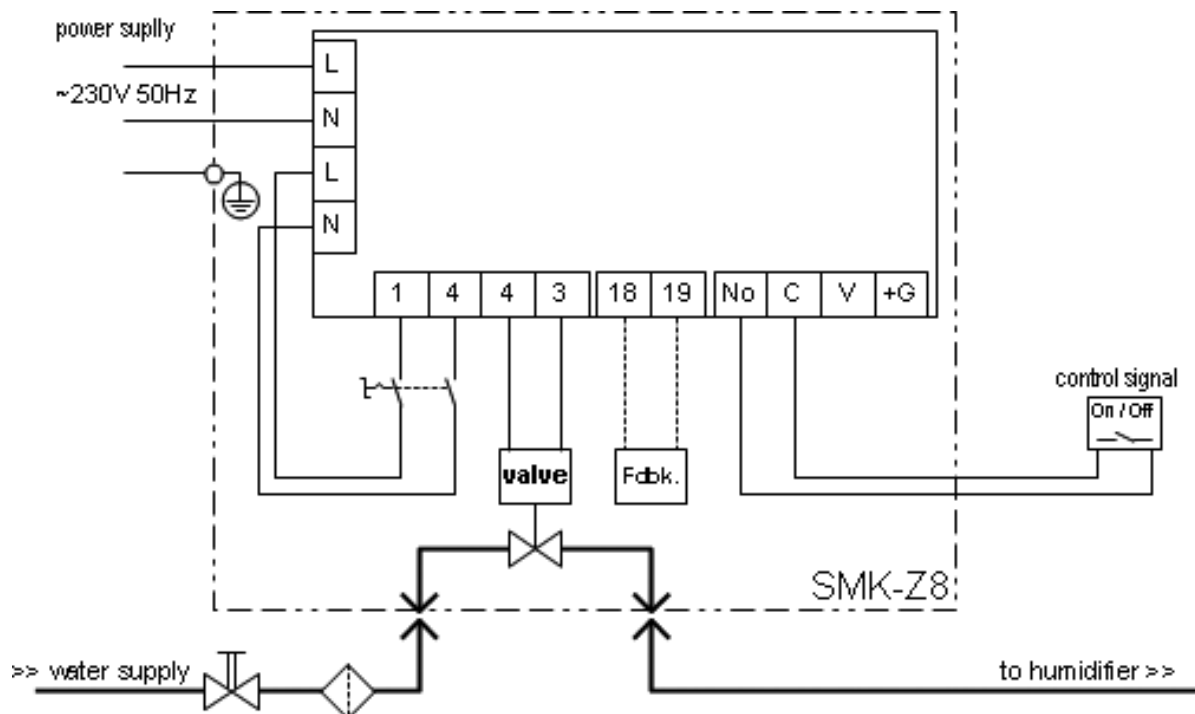

WIRING DIAGRAM OF HUMIDIFIER WITH CIRCULATING WATER SUPPLY

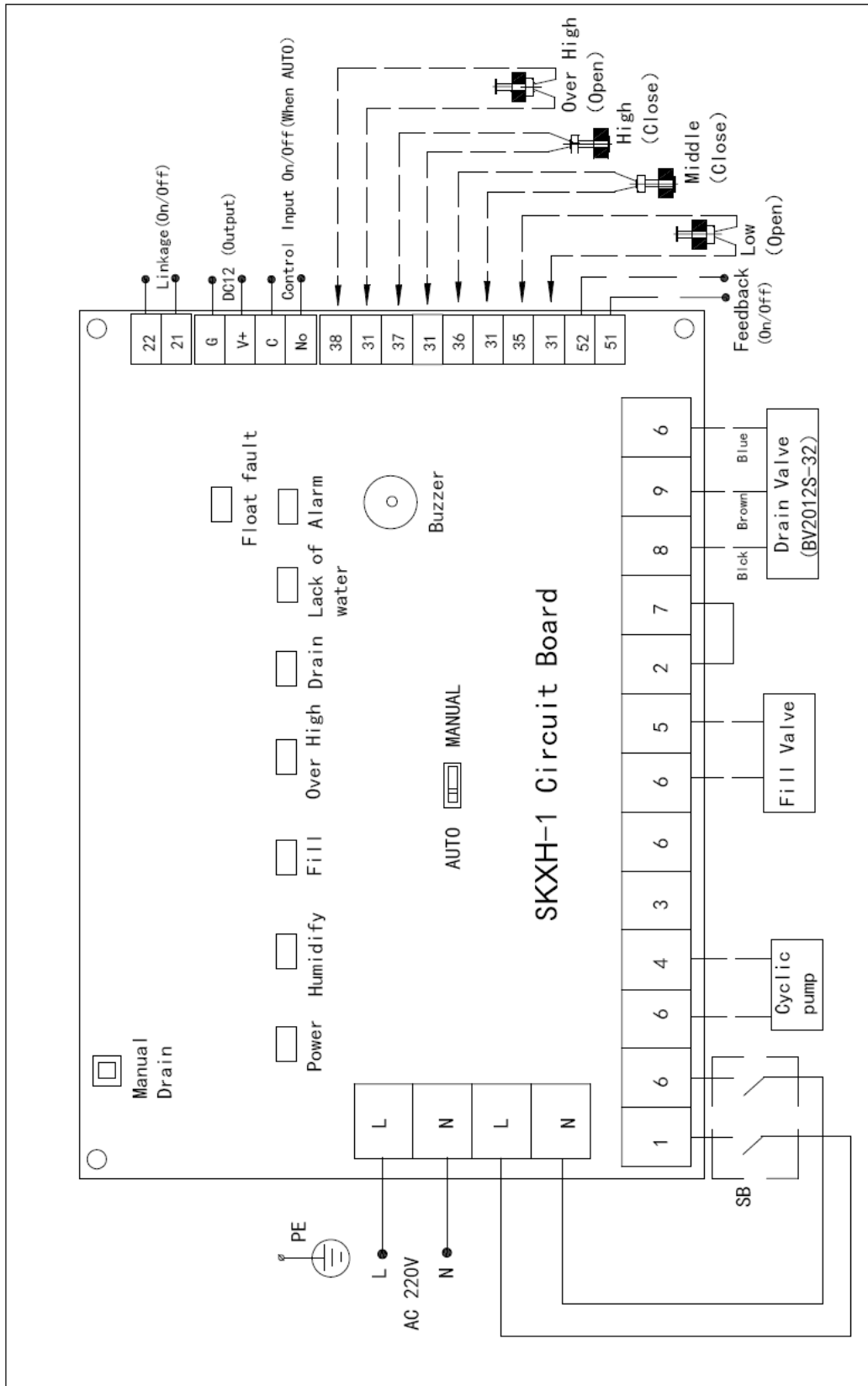

6.5 CONTROL SYSTEM

Complete automatic control, which should be an integral part of any air-conditioning system, enables continuous operation of the device, in many cases is an essential element, and its absence can lead to serious operational problems or failures.

When connecting the communication cables of the devices that are part of the Modbus RTU network (inverters, EC motors, converters, etc.), use a serial topology. This means that, starting from the controller, each successive device in the control panel should be connected to the previous device, not to the controller:

SERIAL CONNECTION TOPOLOGY IN MODBUS NETWORK

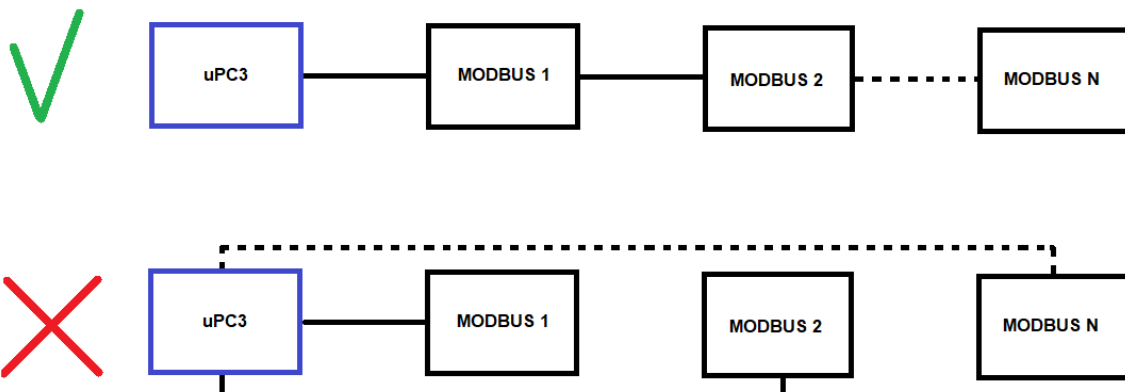

- ! This documentation does not include detailed information on automation assembly, connection, commissioning and system operation. This information can be found in separate documents provided by VTS with the automation kit. In other cases, the automation supplier should provide the relevant information and documentation.
- ! See instructions at www.vtsgroup.com :
- !

CABLE STANDARDS USED FOR VTS AUTOMATION		
APPLICATION	WIRE TYPE	WIRE
Fire alarm relay	[2]	2x0,75
Multifunction switch	[2]	2x0,75
Optional multifunction switch	[2]	2x0,75
Supply air temperature sensor	[1]	2x0,75
Room/exhaust air temperature sensor	[1]	2x0,75
Return water temperature sensor for water heater	[1]	2x0,75
Electric heater (HE) alarm relay	[2]	2x0,75
Air-side antifreeze thermostat to protect the water heater from freezing	[2]	2x0,75
Analog controlled water heater valve	[1]	3x0,75
Electric heater power control input	[1]	3x0,75
Water heater circulating pump contactor		3x1,5
Alarm relay of refrigerator / cooling unit / heating pump	[2]	2x0,75
Refrigerator startup input	[2]	2x0,75
Chiller startup input - stage I	[2]	2x0,75
Chiller startup input - stage II	[2]	2x0,75
Recirculation throttle actuator	[1]	3x0,75
Cross-flow heat exchanger bypass actuator	[1]	3x0,75
HMI Basic UPC control panel - interface with limited functionality	[3]	UTP 1x2
HMI Advanced UPC control panel - full-function interface	[4]	8x0,1

ID	TYPE WIRED	DESCRIPTION
[1]	Cables for transmission of control signals - shielded copper wires. PVC insulation.	Rated voltage 300/500 V. Ambient temperature: from 30 °C to 80 °C.
[2]	Copper conductors PVC insulation	Rated voltage 450/750V. Ambient temperature: from -40 to 70 °C
[3]	Copper conductors PVC insulation	Voltage rating of 150 V. Ambient temperature: - 20...60°C
[4]	Flat unshielded data cables.	Voltage rating of 150 V. Ambient temperature: - 20...60°C

6.6 AIR DAMPERS

Dampers used in VVS400-VVS650 air handling units are equipped with two separate stems as standard, and should be driven by two actuators. The drive of the aforementioned air dampers is based on a single actuator (regardless of its maximum torque) may cause improper operation of the damper. For air handling units equipped with water heat exchangers (heaters, coolers, glycol recovery), the actuators of air dampers of supply units should be equipped with a return spring to ensure its spontaneous closure in the event of a power failure.

7 FIRST START-UP

7.1 PREPARING FOR THE FIRST START-UP



- ! Before proceeding with the activities leading to the first startup, read the operating instructions of the operator panels.
- ! The air conditioning unit can only operate with filters installed.
- ! Replace air filters with clean ones after the first few hours of operation.
- ! According to the Ecodesign 2018 directive, the filter unit must be equipped with a filter contamination indicator or control system alarm to show when the pressure drop exceeds the maximum permissible value for the filter. In addition to the full control system, VTS offers a separate device - a pressure transmitter with instructions (to be mounted on the inspection door in the filter section). Detailed information can be found in a separate document for the differential pressure indicator and at www.vtsgroup.com.

7.1.1 CHECK THE CONDITION OF THE INSTALLATION

PRE-STARTUP ACTIVITIES

Correctness of application of the device	As part of the initial start-up procedure, it is necessary to verify that the air conditioning/ventilation/heating unit in question has been constructed and installed in accordance with the structural/installation design and the manufacturer's guidelines.
Completeness of installation	Verify the presence of all AHU features and accessories (filters, dampers, actuators, valves, heaters/coolers, etc.) based on the technical sheet - a complete list of AHU components can be found in the technical sheet of the AHU, as well as on the labels of individual delivery packages and the installation design documentation.
Connection to air ducts	Check that all ventilation equipment and its components have been mechanically installed and connected to the duct system.
Condition of air ducts	Check that the channels are clean and the adjustment elements on the channels are pre-adjusted.
Quality of installation at the facility	Check whether the functional systems and components of the equipment were not damaged during the installation or other activities, As well as automation components,
Connection of external sources of cooling and technological heat	Check that the plumbing systems and freon installation is complete and ready for operation, and that the correct amount of heating or cooling medium has been introduced to start the air handling unit.

OPERATIONS BEFORE STARTING UP (cont'd)

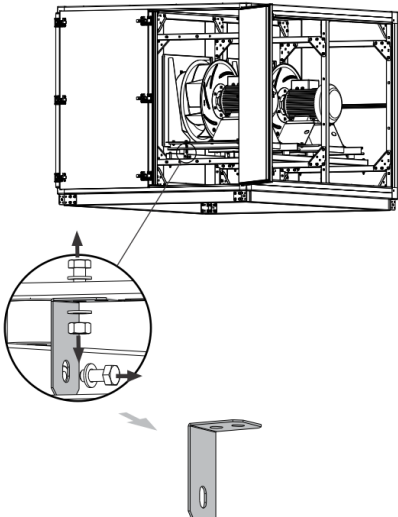
<p>Electric system</p>	<p>Before closing the electrical equipment connection boxes, check:</p> <ul style="list-style-type: none"> • Based on the relevant wiring diagrams - compatibility of connections, • The use of safeguards for all electrical equipment, • fixing all screws and proper installation of support components and electrical connections (including unused auxiliary terminals - if any), • cables and wires - to ensure compliance with all regulations regarding safety, functionality, cross sections, etc, • appropriate ground and protective systems, • inside the connection boxes - whether there are no loose or redundant cables, • condition of sealing surfaces and seals
<p>Grounding installation</p>	<p>Check that grounding cables are installed, connecting control systems to ventilation ducts.</p>
<p>Condensate installation</p>	<p>Check that the condensate traps and condensate drainage systems from the condensate gutter are installed. Traps must be filled.</p>
<p>Automation peripherals</p>	<p>Check the connections of peripheral devices - because the optional equipment of the control panel such as operator panels and some temperature sensors may differ depending on the selected configuration. Check that they are complete and their connection has been made in accordance with the documentation and schematics (pay special attention to the correct connection of the 24V power supply and Modbus communication wires, as their confusion may damage the entire communication bus of the control panel).</p>
<p>Electrical supply to the device.</p>	<p>Check the correctness of the power supply connection to the main circuit breaker - to the switchgear of the block must be supplied with voltage of appropriate power in accordance with the wiring diagram of the device in the relevant section of its technical card and the User's Manual (Technical and Operating Documentation) of the automation, in particular: controller, power and control switchgear and frequency converters.</p>
<p>Rotating elements</p>	<p>Check whether the rotating elements (fans, motors, rotary exchanger) do not have a safety element installed for transport (rotation locks, vibration isolator locks). If they are present, remove them.</p> 

OPERATIONS BEFORE STARTING UP (cont'd)

Electric heater	<p>Check the correct connection of the power supply to the electric heater (if any) - voltage of the appropriate power must be supplied to the heater switchgear in accordance with the wiring diagram of the device in the relevant section of its technical card and the User's Manual (Technical and Operational Documentation).</p> <p>During the operation of the air handling unit (and also before its first startup), when the heater is not running, dust may settle on the heating elements. When the heater is switched on again, heavy soiling can cause the smell of burning dust or even a fire hazard.</p> <p>Regularly (annually), and especially before the first start-up and before the start of the heating period, check the condition of the electrical connections, the condition of the heating elements and how dirty they are. Remove any dirt with a vacuum cleaner with a soft squeegee or compressed air.</p> <p>The operation of the overheating protection and the no-airflow protection should also be checked regularly. The air speed in the AHU during heater operation should not be less than 1.5 m/s.</p>
Closing the inspection panels.	<p>Check that the inspection panels are closed - the rotating parts of the control panel can be a health and life hazard when the protective covers are removed</p>

OPERATIONS BEFORE STARTING UP (cont'd)

Air filters	<p>Before closing the filtration section, make sure:</p> <ul style="list-style-type: none"> • The film from the filters has been removed, • The filters are mounted in the guides so that the pocket is in the vertical position, • the condition of the filters and the correctness of installation in the guides was checked, • differential pressure control settings (if used) have been checked, which determine the allowable static pressure differential that qualifies the filter for replacement
Air heaters (water, glycol, DX)	<p>Check the following items:</p> <ul style="list-style-type: none"> • condition of the heater fins, • Connection of supply and return pipelines, • Fixing the capillary of the antifreeze thermostat to the casing, • setting of the antifreeze thermostat (factory setting: + 5°C), • whether the heater control valve has been installed according to the markings on its casing
Electric heater	<p>Check the following items:</p> <ul style="list-style-type: none"> • Electrical connections in accordance with the wiring diagrams for connecting heaters, • connection of the thermal switch, • pressure switch connection, • Whether the heating equipment does not touch other components in the heating section, • that the heaters are not damaged
Air coolers (water, DX, glycol)	<p>Check the following items:</p> <ul style="list-style-type: none"> • condition of radiator fins,

	<ul style="list-style-type: none"> • Connection of supply and return pipelines, • The correct position of the condenser to the direction of air flow, • Installation of the U-TRAP - fill it with water before starting the device, • correctness of condensate drainage
Humidifier	<p>Check the following items:</p> <ul style="list-style-type: none"> • The correctness and tightness of water pipe connections, • electrical connections in accordance with electrical diagrams
Recuperator (cross, counter-current- hexagonal)	<p>Check the following items:</p> <ul style="list-style-type: none"> • condition of the exchanger fins (dirt, mechanical damage) • operation of the damper assembled in the plate heat exchanger section • check that the condensate eliminator is properly installed and that its position relative to the direction of air flow is correct • in air handling units with a condenser on the supply side of the fan, check the size and installation of the condensate trap and the capacity of the condensate drainage system • Fill the U-TRAP with water before starting the control unit.

PRE-STARTUP ACTIVITIES

Rotary heat exchanger

Before starting the exchanger, check the following items:

- after installing the v-belt - whether the rotor rotates freely,
- the distance between the rotor and the casing, adjust the sealing brushes, if necessary,
- electrical connections,
- whether the brush seal is installed on the pressure side of the exhaust air,
- after installing the drive belt and starting the exchanger, make sure that the direction of rotation of the rotor is consistent with the location of the brush seal and the direction of exhaust air flow.

Direction of rotation of the exchanger depending on the direction of air flow and the location of the brush seal

SUPPLY 
 RETURN 

VVS021-VVS300

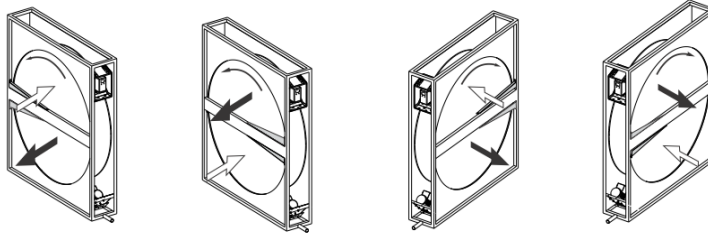

VVS400-VVS650

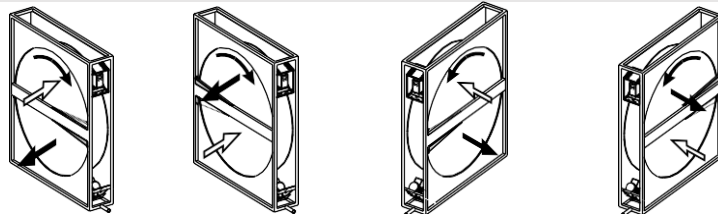

OPERATIONS BEFORE STARTING UP (cont'd)

Fan unit

Check that:

- there are no objects within the range of the fan that can be sucked into the impeller when the fan is switched on,
- the fan impeller rotates freely, without friction with casing components,
- the motor is properly set up, and the system and operating conditions comply with the data given on the nameplate (supply voltage, current, frequency, winding connections),
- the fan impeller rotates freely,
- the cooling air of the engine can flow freely through its casing,
- grounding and protective connections are made properly,
- the design speed of the fan will not be exceeded (see the technical data of the device),
- all bolts, support components and electrical connections are properly fastened,
- power cables inside the fan section are away from any drive components and are attached with appropriate terminals to the electrical wires,
- all dampers are set according to the technical documentation of the device,
- the direction of rotation of the rotor is the same as the direction of the arrow located on the fan casing (pulse on the fan). if they are arranged in different directions, change any two phases in the motor junction box or the direction of rotation on the frequency converter with each other,
- v-belt tension and pulley position is as required.

PRE-STARTUP ACTIVITIES (COMPOUND HUMIDIFIER)

TEST STARTUP AND CONTROL

- 1) Before using the humidifier, check the connection of each part, electrical wiring and water piping.
- 2) Open the main water valve on the inlet, and then turn on the power, there was no leakage. The wet filter should soak well.
- 3) Before the first start-up, drain the water from the pipelines. Turn on the humidifier when the drainage water becomes clear!
- 4) Connect the power supply and check for unusual sounds. (Circulating water model)
- 5) After 15 minutes of stable operation of the humidifier, check all parts and confirm that there are no unusual sounds or specific smell of the water pump. (Circulating water model).

NOTES FOR USE

- 1) All parts are adjusted before leaving factory. Please do not make bold to adjust it, or working status may be negatively affected.
- 2) Do not turn on the humidifier when the ambient temperature cannot meet the requirements.
- 3) When doing the maintenance, please shut down both power supply and water supply.
- 4) When not using it for a long period of time, please shut down both power supply and water supply (for circulating model, shut down both the water pump and drain the water tank)
- 5) Periodic checks on power supply, water pipelines and connection parts should be made to confirm the working status. When error state happen, turn off the humidifier and shut down both power supply and water supply immediately.
- 6) All parts are checked and matched before leaving the factory. They should not be modified, as this may adversely affect the working conditions.
- 7) Do not turn on the humidifier when the ambient temperature does not meet the requirements.
- 8) Turn off the power and water supply during maintenance.
- 9) When not in use for an extended period, turn off the power and water supply (for a circulating model, turn off the water pump and empty the water tank)
- 10) Periodically inspect the power supply, water piping and connection components to check the operating condition. If an error occurs, immediately turn off the humidifier and the power supply and water supply.

7.1.2 CONFIGURATION OF PARAMETERS AND FUNCTIONS

See "Description of uPC3 controller masks" and instructions:

- Installation, Operation and Maintenance Manual - VENTUS Software - uPC3 control / VTS Ventilation Software for air handling units (Ventus - Application uPC3) uPC3 controller - connection diagram,
- Controls of the modular VENTUS unit - short instruction of wiring, assembling and start-up step by step / Short instruction of assembly, wiring and start-up step by step (VENTUS units equipped with automation in the CBX standard),
- Installation, Operation and Maintenance Manual VENTUS Heat Wheel Drive / rotary heat exchanger drive manual,

7.1.3 CONFIGURATION OF DX AND DX-H (REVERSIBLE) EXCHANGERS



- ! If the unit is equipped with a DX chiller, which is connected to an external condensing unit, configure the number of cooling (heating) sections and the method of communication with the condensing unit.
- ! This item does not include the factory built-in heat pump.

The default parameters of the uPC3 controller for DX exchangers are suitable for most devices on the market. According to demand, you can change the parameters (regardless of the function and number of exchanger stages).

THE PERCENTAGE VALUE OF THE CONTROLLER, FORCING START / STOP OF THE DIGITAL OUTPUT / OUTPUTS RESPONSIBLE FOR ALLOWING THE EXCHANGER OPERATION

(screen A11 for heating, screen B05 for cooling)

Default values allow the DX motor to start quickly even at low levels of heating/cooling demand, followed by smooth control by changing the 0-10V signal, which works well for current exchangers with inverter motors. For DX systems with older-type motors (high-power motors without smooth control), the start threshold of the first stage can be set correspondingly higher (e.g., to 50%) to block allowing its operation at low demand for heating/cooling and thus avoid jump on/off cycles.

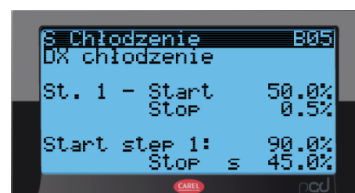
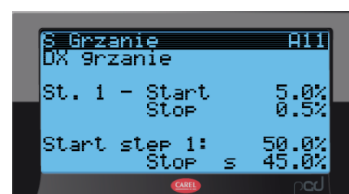

MINIMUM SYSTEM START-UP AND SHUT-DOWN TIMES AND MINIMUM INTERVAL BETWEEN START-UPS

(screens A10/A14/A18 for heating, screen B04 for cooling)

Appropriate values of these parameters protect the DX circuit from too frequent state changes, which can cause temperature instability and shorten the life of its components. If the system is additionally protected by appropriate delays on the part of external automation, these parameters in the controller can be reduced to single seconds to avoid overlapping waiting times.

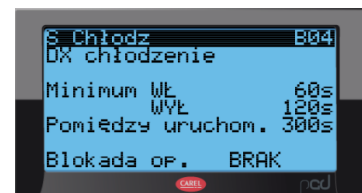
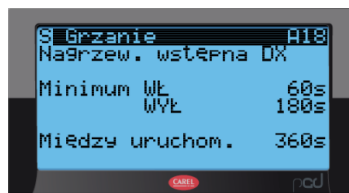
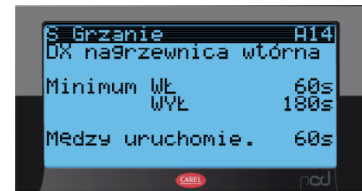
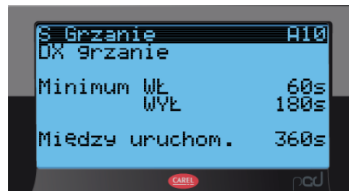

LOGIC OF DIGITAL OUTPUTS CONTROLLING THE DX CIRCUIT

(screens A01, A02, A05, A06 for heating, screens B01, B02 for cooling)

By default, all control digital outputs are treated as normally closed (NC) - it is possible to change this state to normally open (NO).

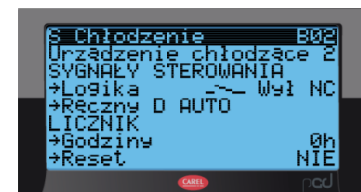
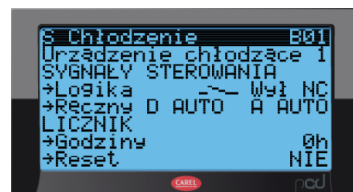
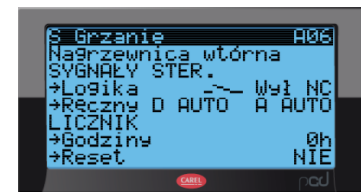
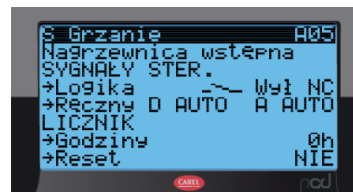
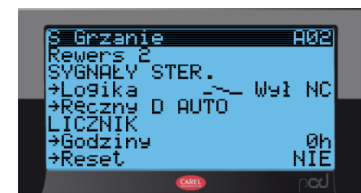
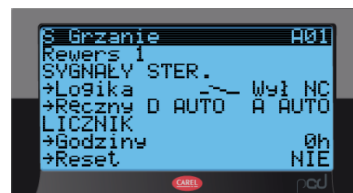

ADJUSTMENT OF VOLTAGE LEVELS CONTROLLING HEATING/COOLING FUNCTIONS

(screen A22)

By default, the power control of both functions is implemented by the controller using voltages in the range of 0-10V, but if the target circuit is controlled with voltages of other levels (e.g. 2-10V, 0-5V) it is possible to adjust the output signals provided by the uPC3

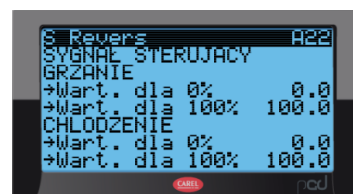

OPERATING PERMIT FROM OUTSIDE TEMPERATURE

(screen A23)

Parameter with default value set to -20.0C, blocking the possibility of starting the system when the outside temperature is below the set temperature. It is intended to protect the DX system from operating in adverse weather conditions.

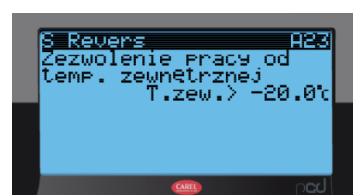

7.1.4 POWER CONFIGURATION OF OPTIONAL ELECTRIC HEATERS



! If the unit is equipped with an electric heater, the heater's heating sections must be configured.

CONFIGURATION OF ELECTRIC HEATER POWER STAGES

Read the power distribution from the schematic or technical data sheet. For example, we have:

0-10V DC = 25%, ST2 = 25%, ST3 = 50%

This notation means that the step-adjustable part of a given heater is 25% of its power (0-10V DC).

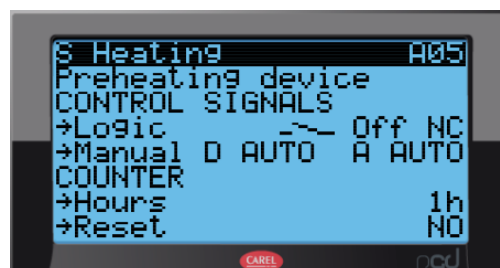

The second stage - step-attached (ST2) is also 25%, while the third stage - step-attached (ST3) is 50% of the total power of the heater.

These parameters should be reflected in the appropriate settings of the uPC3 controller. The settings are made on the HMI Advanced screens:

- A05 for preheater,
- A09 for the main heater,
- A06 for the secondary heater,

In the event that the circuit there is no one or both stages connected by step (no ST2 / ST3 markings in the diagram), in the controller settings, select the value 0% in the appropriate position.

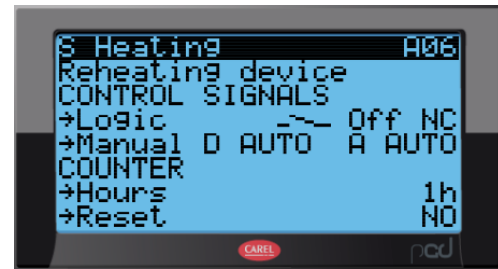
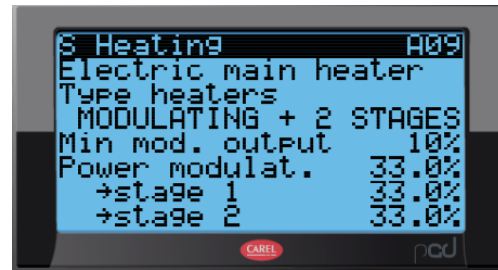

7.2 AHU COMMISSIONING

7.2.1 AHU STARTUP



- ! Commissioning is to verify that the control panel is assembled in accordance with the art, technical documentation and is ready for operation.
- ! Commissioning and adjustment of ventilation / air conditioning systems can only be performed by qualified and competent technical personnel, equipped with the necessary control equipment.
- ! For air handling units equipped with a secondary filtration section, it is recommended to start the system without secondary filter cartridges.
- ! The fan should be started with a lower load than the nominal load and gradually brought to the nominal operating parameters. Lowering the load can be achieved by opening the inlet damper of the unit, and in addition, if the motor is powered by a frequency converter, by lowering the speed.
- ! Always make sure that for the designed operating parameters the current supplied to the motor, is not greater than its rating.
- ! Ignoring first-start recommendations can lead to engine overload and permanent damage.
- ! Refer to instructions for controller settings

After startup, check that:

- there are no disturbing sounds from the engine,
- There is no significant vibration of the control panel.

The control panel should operate for about 30 minutes. After that, turn it off and check each section. Special attention should be paid to:

- Air filters (whether they are not damaged),
- patency and correctness of condensate drainage,
- fan unit (belt tension - for belt drive, fan and motor bearing temperatures).

It is recommended to provide pre-opening of the damper at the inlet to the air handling unit before the fan is activated (VTS control standard). This has a certain effect on the durability and performance of the damper and eliminates the activation of pressure regulation.

Replace the air filters before restarting the air handling unit.

Achieving the required performance of the air handling unit depends, among other things, on the regulation of the air duct network and the correctness of the control and test measurements carried out.

7.2.2 MEASUREMENT OF AIR VOLUME FLOW AND CONTROL OF AIR HANDLING UNIT EFFICIENCY

Air volume measurement is an essential measurement for:

- the first commissioning and technical acceptance of the air conditioning unit,
- if the system does not work according to requirements and expectations,
- periodic inspection of the operation and efficiency of the air conditioning unit,
- replacement of fan assembly components.

Before taking measurements and adjusting, make sure that the dampers on all grilles or gates are set as designed.

Determining the amount of air flow is most often based on measuring the average velocity of air flow in a test cross-section of a duct. One of the most common methods for determining the average flow velocity is the cross-sectional sounding method using a Prandtl tube and measuring the flow velocity-related average dynamic pressure.

The key factors that affect measurement accuracy are:

- the position of the measured cross-section in relation to the elements that cause distortion of the flow velocity (elbows, orifices, tees, butterfly valves, etc.),
- the number and location of test points in the measured section,
- stable and constant airflow,

The measurement should be carried out in a section of the duct with parallel walls and straight sections, at least 6 times the hydraulic diameter of the duct or the corresponding diameters in front of the test point and no less than 3 diameters behind it. In a real ventilation system, finding such a long straight element may be a problem. In this case, the location of the cross-section should be determined where the least flow disturbance is expected, increasing the number of measurement points. The location of the measuring cross section should be determined at the system design stage.

As an estimate, the measurement result is considered sufficient if it does not differ by more than $\pm 10\%$ from the design quantity. In the case of larger discrepancies, approximation of the measurement result to the design value can be achieved by:

- adjusting the network of ventilation ducts,
- changing the setting of the main throttle,
- changing the fan speed

Before starting measurements and adjustments, make sure:

- dampers on all air grilles or air diffusers are set as designed,
- set the fresh and recirculating air dampers (if applicable) to the final position - 100% fresh air or full recirculation,
- measure the current drawn by the fan motor. if necessary, minimize the air flow with the main damper or reduce the fan speed.

The quantification of air flow is based on the measurement of the average velocity of air flow in the cross-section of the ventilation duct. One of the most common ways to determine the average velocity is the cross-section measurement method with a Prandtl tube and the measurement of the average dynamic pressure.

The most important factors affecting measurement accuracy are:

- the location of the measured cross-section in relation to the elements,
- the number and location of test points in the measured section,

- stable and constant airflow.

It is recommended that NOT to LOCATE THE MEASUREMENT SECTION directly after network elements that cause flow deformation (elbows, reductions, three-way connections, silencers, fan, etc.) because a back draft may appear in the cross section.



! It is recommended NOT to locate the measuring cross section directly after network elements that cause flow deformation (elbows, reductions, three-way connections, dampers, fan, etc.) because a back draft may appear in the cross section.

The measurement should be carried out on a section of duct with parallel walls and straight sections at least 6 times the diameter of the duct or equivalent diameters before the test point and no less than 3 diameters after it. In an actual ventilation system, finding such a long straight section may be a problem. In such a case, a measuring section should be determined at the location where the least airflow disturbance is expected, and the test point network should be intensified. The location of the measuring section should be determined at the system design stage. Detailed recommendations for measuring airflow and locating test points are specified in ISO 5221.

It is estimated that the result is correct if it does not differ by more than $\pm 10\%$ from the design. In the case of larger disparities, the flow performance as designed can be achieved by:

- adjustment of the ventilation duct network,
- changing the adjustment of the main throttle,
- changing the speed of the fan.

When increasing the speed of the fan, always control the power consumption of the motor and do not exceed the designated current rating. For durability and acceptable performance, it is also very important not to exceed the maximum impeller speed. In justified situations, when there is a need to increase the airflow capacity, it is recommended to use a more powerful fan motor.

In systems with dampers that automatically change the proportions of fresh air, circulating air and exhaust air, or the proportions of flow through the by-pass, capacity measurements and adjustment of the main damper should be made at one extreme position. Then the air ratio and total capacity should be checked at the other extreme position and, if necessary, the appropriate adjustment should be carried out to obtain the correct ratio while keeping the total capacity constant.

7.2.3 STARTUP INTERFACE SELECTION

SWITCHBOARD START-UP

Turn on the power of the control panel

Select, connect, and enable HMI Advanced ¹⁾	Physical	Virtual http://192.168.1.111	mHMI application					
Switch OFF mode to any other arbitrary mode (work profile) according to preference*.								
	Changing the state of the device (operation mode)							
	OFF Panel operation off (voltage reaches the panel)							
	ON							
	<table border="1"> <tr> <td>ECO</td> <td>One of the user configuration profiles</td> </tr> <tr> <td>OPTI²⁾</td> <td>One of the user configuration profiles</td> </tr> <tr> <td>COMF</td> <td>One of the user configuration profiles</td> </tr> </table>			ECO	One of the user configuration profiles	OPTI²⁾	One of the user configuration profiles	COMF
ECO	One of the user configuration profiles							
OPTI²⁾	One of the user configuration profiles							
COMF	One of the user configuration profiles							
StBy								
The state of readiness of the device for operation. In the StBy state, the set room temperature is maintained. The fans are periodically activated to maintain the required air temperature. This mode is best at night when there is low or zero heat occupancy in the building.								
AUTO								
Operation of the device according to the schedule and calendar								

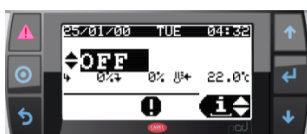

- ! The startup of the control panel is absolutely blocked by a fire alarm, the tripping of the thermal protection of the fan motors, the triple tripping of the protection of the electric heater and the triple tripping of the antifreeze thermostat. Each of these events requires the cause of the alarm to be removed and then cleared.
- ! The correct operation of the power supply and the proper functioning of the BIOS is indicated by the illumination of the yellow and green LEDs on the PCB of the controller. The system is ready for operation after half a minute after the power is switched on.
- ! - * Changing from OFF to another mode is also available from the HMI Basic 2HY.

1) - select one of the options

2) - option not available in newer software versions

7.2.4 HMI ADVANCED INTERFACE

HMI ADVANCED - NAVIGATION

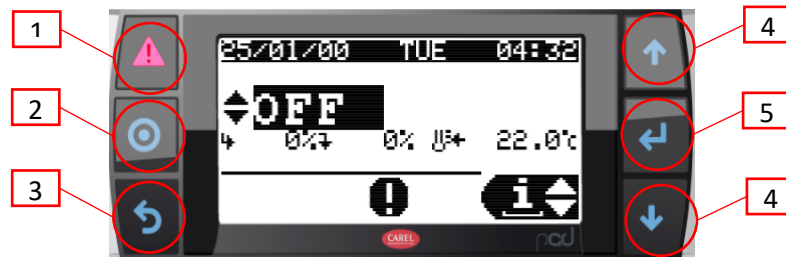

Simulation of equal presses in WEB HMI

1 "Alarm" button (call up active and archived alarms, delete alarms). When the alarm is active, the button is illuminated in red.

2 Button to change the operating modes (OFF/Auto/Low/Econo/Comfort). Approval with ENTER button.

3 ESC button (return to previous field or screen)

Arrows to navigate up and down and to change parameter values
UP:

- Moving up through the menu screens, (when the cursor remains in the upper left corner)

4 • Increasing the value of the parameter

DOWN:

- Moving down through menu screens, (while the cursor remains in the upper left corner)
- Decreasing the value of the parameter

5 ENTER button.

- selection of the parameter to be changed,
- transition to another parameter,
- validation of the selected value



! The parameters available in the LCD display window depend on the type of control panel and automation system application. Therefore, for AHUs without a heater, you will not see options related to the heating section.

! The HMI Advanced cannot serve as a room temperature sensor.

HMI ADVANCED NAVIGATION cont.

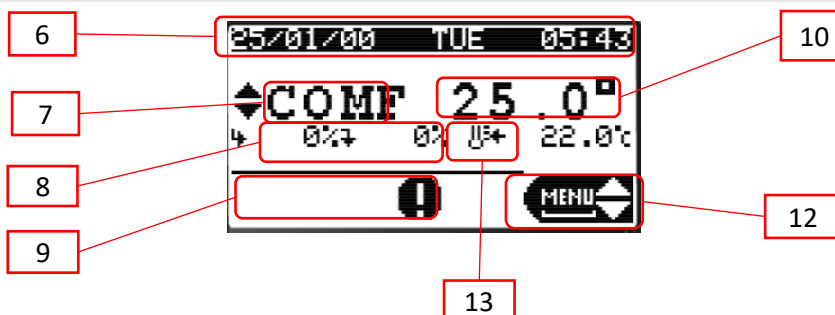

6	Current date and time.	12	HMI Advanced Work Module:
7	Current job profile		<ul style="list-style-type: none"> • "Info" module (preview of the operation status of the control panel - available without logging in), • "Set" module (changing the settings of user parameters: capacity, temperatures, humidity, CO2 and setting the timer - available without logging in), • "Menu" module (allows you to make configuration changes to the control panel and its components and programming of EC motors, available only after logging in)
8	Current fan controllers		
9	Status of the air handling unit (running/stopping fans, heating/cooling, switching on recovery)		
10	Current value of the leading temperature		
11	Set leading temperature value		
13	Operating status icon:		
	Opening/closing throttles		Dehumidification
	Fan operation		Active recovery
	Heating		Detention on demand
	Cooling		Emergency stop
	Moisturization		Active calendar



- ! The parameters available in the LCD display window depend on the type of control panel and automation system application. Therefore, for AHUs without a heater, you will not see options related to the heating section.
- ! The HMI Advanced cannot serve as a room temperature sensor.

7.2.5 HMI BASIC 2HY

HMI BASIC 2 HY

HMI Basic 2 HY is a basic control panel, designed to operate VTS air handling units equipped with uPC3 controller. The functions realized are:

- Starting and stopping the control panel,
- mode selection,
- The ability to view and change the parameters of the various modes of operation (temperature, humidity, CO2 level, supply and exhaust fan speeds),
- reading of leading, outside and room temperatures (built-in room temperature sensor),
- Setting AHU operation according to the schedule,
- handling of alarms (viewing, deleting)

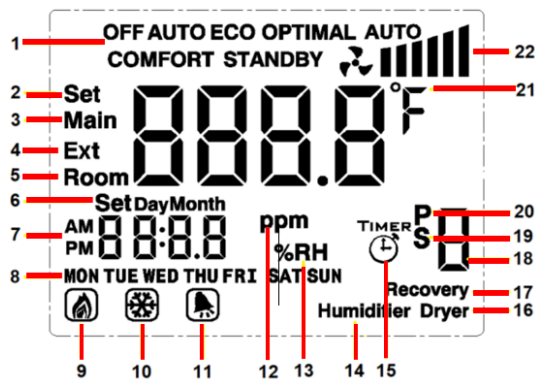

- | | | | |
|----|---------------------------|----|---------------------|
| 1 | Current mode of operation | 12 | Air quality |
| 2 | Setup temperatures | 13 | Moisture |
| 3 | Temperature leading | 14 | Moisturization |
| 4 | Outdoor temperature | 15 | Daily schedule |
| 5 | Room temperature | 16 | Dehumidification |
| 6 | Date setting | 17 | Retrieved from |
| 7 | Clock | 18 | Option number |
| 8 | Day of the week | 19 | Special Schedule |
| 9 | Heating | 20 | Periodic schedule |
| 10 | Cooling | 21 | Temperature unit |
| 11 | Alert | 22 | Fan operation level |

Current control of the operating level of the fans

Symbol	Fan control
	0 %
	0 < % ≤ 60
	60 < % ≤ 80
	80 < % ≤ 100



BUTTON	FUNCTION
	changing the operation mode / entering the setting menu / returning to the previous menu
	approve selection / move to next setting parameters / return to general setting menu
	switch between displayed temperatures / exit to home screen / turn off screen
	changing parameter values







- ! In the absence of communication with the controller, the HMI Basic 2 HY will only display the current room temperature.
- ! Activation of the panel in the settings of the air handling unit controller The panel is intended for air handling units equipped with uPC3 controller with software version 1.0.019 or higher. To activate its operation, from the level of HMI Advanced (physical, connected to the controller's pLAN port, or virtual, being part of the visualization application) go to the service menu and on the I01 screen change the last digit of the application code to 7.
- ! The default Modbus address of the HMI Basic 2 HY is 16. It can be changed on the I05 HMI Advanced screen (HMI Basic 2 line).
- ! If there is no communication between the AHU controller and the Basic 2 HY HMI, only the room temperature will be displayed on the HMI screen, and the controller will report the corresponding alarm (A1096).
- ! If there is no communication between the AHU controller and the Basic 2 HY HMI, only the room temperature will be displayed on the HMI screen, and the controller will report the corresponding alarm (A1096).

START-UP OF THE CONTROL PANEL - CHANGE OF THE OFF MODE TO THE ON PROFILE (ECO / OPTI / COMFORT)



On the main screen, hold down the button , then **SET** use successive presses to select one of the modes (**Eco / Opti / Comfort**) and confirm the selection with .

SWITCHING THE PANEL ON AND OFF

To turn off the panel screen, hold down the ON/OFF button . Turn it  on by briefly pressing the same button. Turning off the HMI panel is not the same as with turning off the panel - to turn off the AHU, select the Off mode.

The display backlight is automatically turned off after a user-defined time. Backlighting is activated by pressing any key. After backlighting, it is possible to perform further operations with the panel.





CHANGING THE PARAMETERS OF INDIVIDUAL MODES OF OPERATION

On the main screen, hold down the button , then **SET** then use successive presses to select the mode of interest (Standby / Eco / Comfort) and confirm the selection with .

We now have the option to set the values of the parameters associated with the mode:



- the set temperature,
- moisture,
- CO2 levels,
- supply fan speeds (S),
- exhaust fan speeds (E).



Access to individual settings depends on the configuration of the control panel and its actual components.

Changes are made with   confirmed with . Exit to the  home screen automatically after a moment of inactivity or by pressing .

SETTING THE OPERATING SCHEDULE OF THE CONTROL PANEL

The HMI Basic 2 HY panel is equipped with the ability to set and modify the schedule of the control panel. Changes made from the HMIS BASIC 2HY panel also affect the schedule available in HMI Advanced and visualization - it does not constitute a separate calendar, but allows full access to the existing one.

On the main screen, hold down the button and  then select the Auto submenu with  successive presses and confirm the selection with the  button.

Use now to   select one of the schedules, which is confirmed with the key:

- **Timer** -  a daily schedule, allowing you to program up to 4 mode changes each day at a selected time, separately for each day of the week. Select in turn: the day of the week, activation (On / Off) of each action, the time at which it is to be performed and the mode to be set. Confirming the successive parameters, we move on to the parameterization of the next action (the digits 1-4 displayed on the right side determine which one we are currently setting).
- **P** - periodic schedule, allowing you to select up to 3 periods per year, during which the AHU is to operate in the selected mode (this type of schedule has a higher priority than the daily schedule). We select in turn: activation (On / Off) of individual periods, the date of their end, beginning and mode to be set. Confirming the subsequent parameters, we move to the parameterization of the next period (the digits 1-3 displayed on the right side determine which period we are currently setting).
- **S** - special schedule, allowing you to select up to 6 special days per year, on which the AHU is to operate in the selected mode (this type of schedule has a higher priority than the daily and periodic schedule). We select in turn: activation (On / Off) of a particular special day, its date and mode to be set. By approving the subsequent parameters, we move on to the parameterization of the next special day (the digits 1-6 displayed on the right side determine which one we are currently setting).
- **T** - not used

! Access to individual settings depends on the configuration of the control panel and its actual components.

! Exit to the home screen automatically after a moment of inactivity or by pressing.







ALARM HANDLING

MI Basic 2 HY allows you to view and clear active alarms. When an alarm is present, the main screen shows the bell symbol and the alarm number is displayed in place of the time.

Clearing the alarm, once the cause of the alarm has been removed, is done by holding down  .

PROGRAMMING MODE

With the display turned off by holding down the button, hold down the button to enter the programming mode (changing advanced parameters).

Subsequent presses of  switch between parameters, and use   to set their value. The menu is exited automatically after a moment of inactivity or by pressing  .

Parameter	Scope	Default value	Description
IP	1-255	16	Modbus-address
A1	2400/4800/9600	9600	Modbus - transmission speed
A2	0/1/2	0	Modbus - parity bit (0 = none, 1 = even, 2 = odd)
A3	12/24	24	Clock mode [h].
A4	00/01	00	Temperature units (00 = °C, 01 = °F).
A5	0-300	10	Screen backlight time [s]
A6	-9,9...9,9	0	Correction of built-in temperature sensor [°C].

SPECIFICATION

Type of device	control panel; regulator
Temperature measurement	0°C ... 70°C, 10k NTC
Support	physical membrane keyboard buttons
Communications	Modbus RTU (2400 / 4800 / 9600 bps)
Power supply	110-230V AC
Power consumption	1.5 VA
Display	backlit, graphic LCD
Design	ABS + polyester
Dimensions (S x W x G)	86 x 86 x 17 mm
Permissible Operating Temperature	0°C ... 50°C
Destination	for indoor installation (IP20)
Assembly	in a standard Ø60 installation box on a mounting bracket
Mass	150g



- ! In the absence of communication with the controller, the HMI Basic 2 HY will only display the current room temperature.
- ! Activation of the panel in the settings of the air handling unit controller The panel is designed for air handling units equipped with uPC3 controller with software version 1.0.019 or higher. To activate its operation, from the level of HMI Advanced (physical, connected to the controller's pLAN port, or virtual, being part of the visualization application) go to the service menu and on the I01 screen change the last digit of the application code to 7.
- ! The default Modbus address of the HMI Basic 2 HY is 16. It can be changed on the I05 HMI Advanced screen (HMI Basic 2 line).
- ! If there is no communication between the AHU controller and the Basic 2 HY HMI, only the room temperature will be displayed on the HMI screen, and the controller will report the corresponding alarm (A1096).
- ! If there is no communication between the AHU controller and the Basic 2 HY HMI, only the room temperature will be displayed on the HMI screen, and the controller will report the corresponding alarm (A1096).

7.2.6 BLUETOOTH MODULE AND mHMI APPLICATION

The Bluetooth module is designed for low-power Bluetooth V5.0 connectivity to mobile devices. The module transmits an RS485 [Modbus RTU] serial transmission signal from the main controller to the mobile device using the Bluetooth connection, thus eliminating the transmission cable. To use the Bluetooth module to control the VTS automation control panel, install the dedicated mHMI application on the mobile device and connect to the dedicated mHMI Bluetooth module, which has been connected to the VTS automation switchboard. For VENTUS COMPACT plug-and-play devices, it is installed at the factory, while for other devices it requires connection and configuration by the customer.

BLUETOOTH MODULE

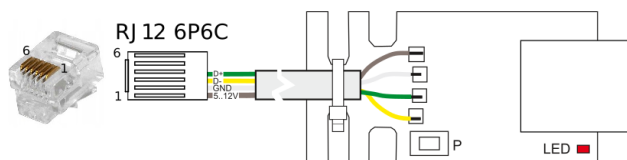

Terminal	PIN	Designation
0	=	grounding (stranded screened wire)
1	1	+VRL 12V
2	2	GND
3	3	Rx-/Tx-
4	4	Rx+/Tx+
5	5	GNS
6	6	+VRL 12V

Data transmission from RS485 [Modbus RTU] to Bluetooth V5.0.

Internally built-in antenna - does not require an external antenna or allow connection.

Power supply

Degree of protection

Ambient temperature

ISM transmission

Dimensions

Assembly

Electromagnetic environments

Degree of environmental pollution

Development conditions

- Due to electrostatic discharge, it requires casing to prevent access to the device during normal operation.
- Attach to the fixed components of the device installation. It should not be possible to approach the module to live parts under dangerous voltage.

P button for configuring serial communication data and pairing functions.

LEDs to indicate transmission and power supply.

5...12 VDC, 1 W (4A fuse)

IP 00

0° C...50 C°

Bluetooth V5.0, ISM 2.4 GHz, Transmission speed: 125 Kbps, 500 Kbps, 1 Mbps, 2 Mbps

60x22x5 mm

Stationary device for building in

Domestic or similar environment and industrial environment

2 according to IEC 62368-1



REQUIREMENTS:

- Automation software uPC3 as of 1.0.26
- Smartphone with systems from versions: Android 9, iOS 11
- Assignment of rights and activation:
 - location (related to bluetooth connection)
 - bluetooth connections

BT MODULE SUPPORT

The device allows other devices to connect through the broadcast system. The default name of the module by which it broadcasts is the factory number of the air handling unit. For devices with an unconfigured control panel number, the module reports as "AHU Bluetooth".

By default, the server allows only previously paired devices to connect, this state is indicated by a disabled LED with a pulse on.

You can allow all devices to connect by holding down the pairing button for about 3 seconds. The LED will then be on with a pulse off. The server can be connected to up to one client device at a time. A server that is actively connected to another device has its LED constantly on.

LED states:

- **Off** - offline mode / no power,
- **disabled with pulse** - server mode with disabled ability to connect new devices,
- **enabled with pulse** - server mode with new device connectivity enabled
- **enabled** - server mode with active connection



- The app includes a tutorial for pairing and connecting the device.

The mHMI smartphone application has been developed for service departments, as well as for about end users of *VENTUS*, *VENTUS COMPACT* and *VENTUS COMPACT TOP* air handling units. The app is available on: Play App Store and Apple App Store.

The application allows both the current change of settings and detailed configuration of the operating parameters of the control panel and its components. The intuitive interface makes it easy to set up the basic functions of the control panel, making operation of the control panel a pleasure even for a user with no previous experience.

CONFIGURATION OF THE UPC3 CONTROLLER - mHMI and HMI ADVANCED

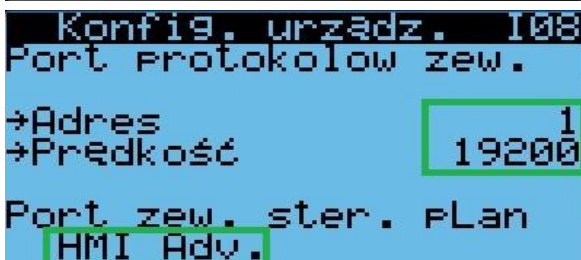
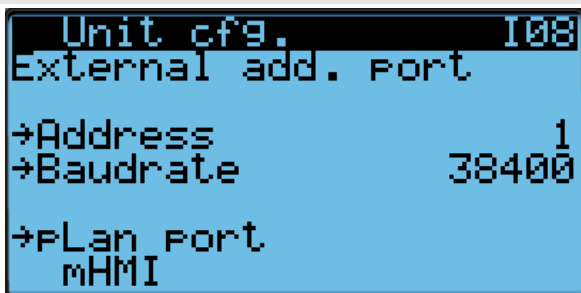

- "Address" - The address of the controller used for communication using the external protocol
- "Speed" - the speed (baudrate) of the external controller protocol.
- "External port of the pLan controller" - type of protocol used by the pLan port of the controller (RJ11 socket)

[for mHMI, the value of the pLan port parameter should be set to "mHMMI" accordingly].

- "Address" - The address of the controller used for communication using the external protocol
- "Speed" - the speed (baudrate) of the external controller protocol.
- "External port of the pLan controller" - type of protocol used by the pLan port of the controller (RJ11 socket)

[depending on the selected HMI, the value of the pLan port parameter should be set to HMI Advanced accordingly]

- The ability to modify the page requires access to a standard service password. You need to set the parameters according to the illustration

BLUETOOTH MODULE ACTIVATION

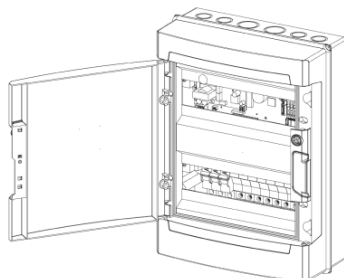

1. Open the power and control switchgear

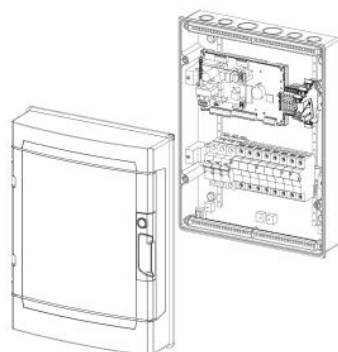

2. Unscrew the front panel of the case

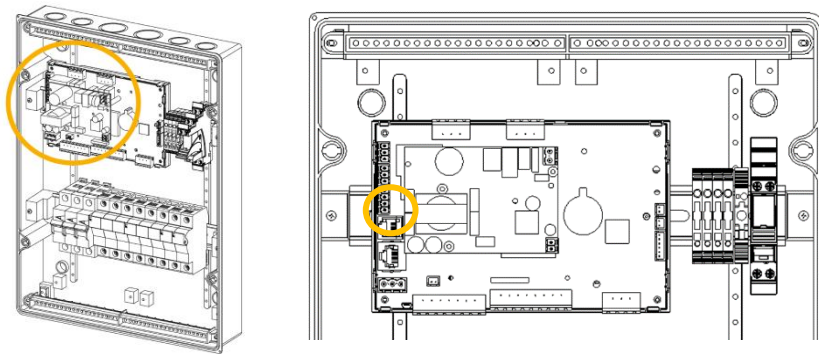

3. The Bluetooth module should be plugged into the uPC3 controller (if supplied separately it should be plugged in)

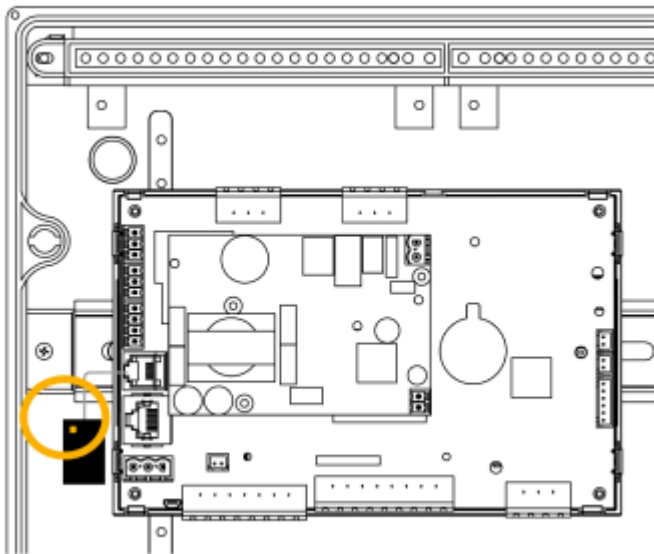

4. Find the button on the Bluetooth (BT) module and press it until the LED starts flashing. This indicates that the BT is in pairing mode. Then go to the app and pair the PBX with the app. Pairing mode is active for 30s.

ADDING A DEVICE

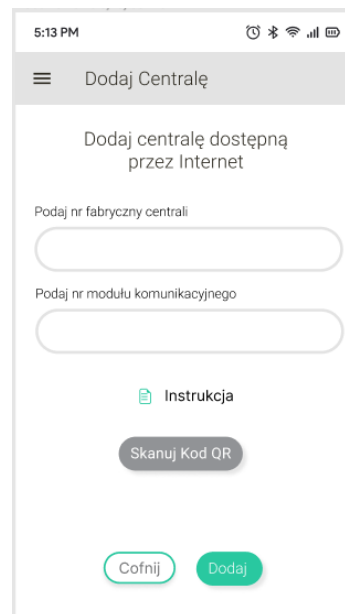
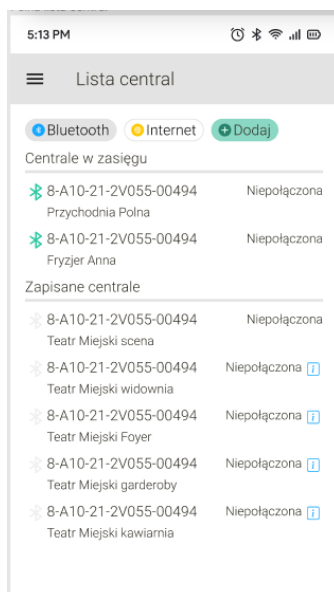

ACTIVATION OF THE DEVICE

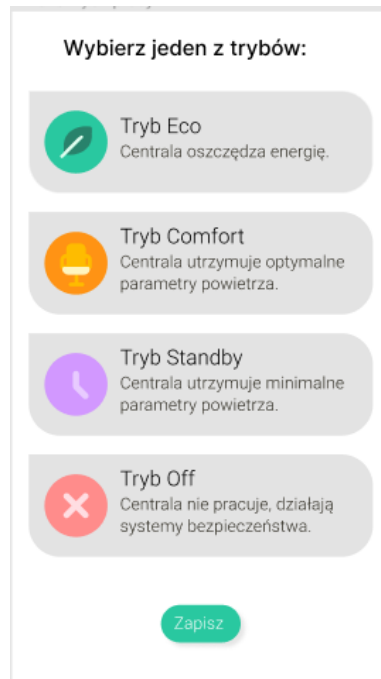
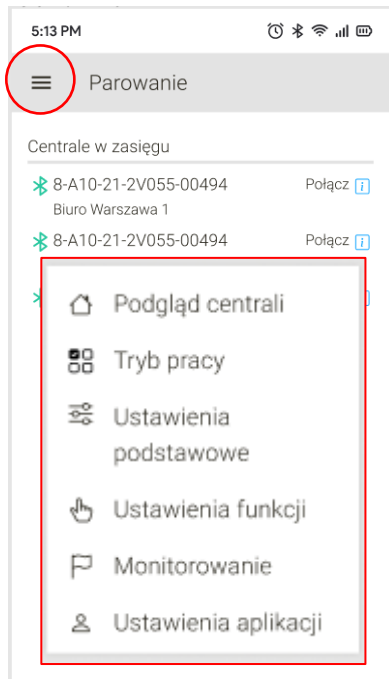

Select a paired device

Then, in the Menu, select one of the operating modes Operation Mode "On":

- Eco
- Comfort
- Standby
- Auto

Save your selection

REVIEW OF SELECTED ASPECTS OF THE mHMI APPLICATION



- The app includes a tutorial for pairing and connecting the device.

PANEL PREVIEW

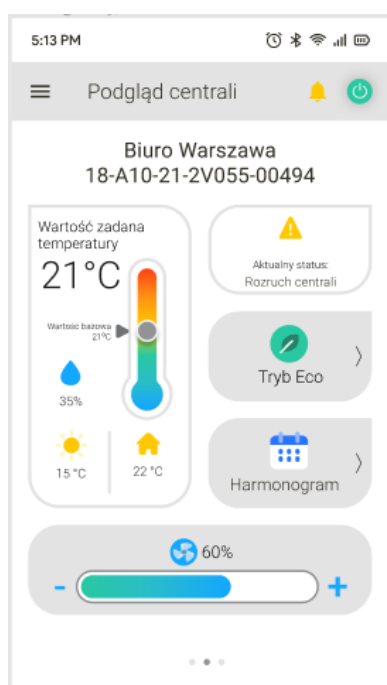

The PBX Preview view places the basic parameters of the PBX operation :

- outdoor air temperature,
- indoor air temperature,
- Set air temperature (leading sensor),
- Degree of fan speed control,
- HQ status,
- selected operation mode of the control panel: (eco, opti, comfort, auto, off)

Changing the set temperature

After clicking on the Thermometer icon, the user can smoothly adjust the temperature within limits depending on the mode.

Changing the operation mode of the control panel

After clicking on the Modes icon, it is possible to change the current mode, as well as change the settings for the mode.

Change of Work Schedule

After clicking on the Schedule icon, it is possible to change the time settings with the assignment of modes to the harmonogram.

Changing fan speeds

In the bar at the bottom of the screen, it is possible to change the fan speed settings (within the settings specific to the operation mode). This can be done by clicking on + or - .

OPERATING MODE PARAMETERS

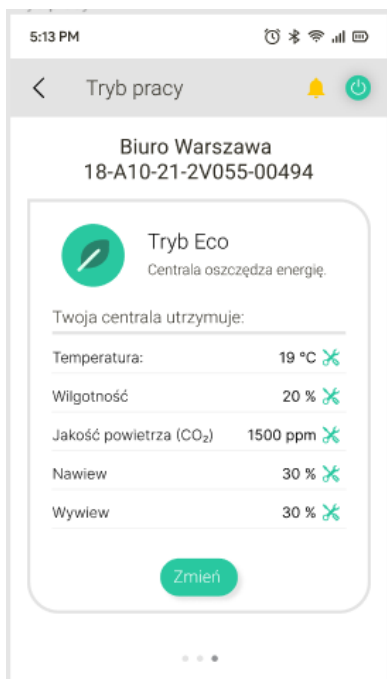

The Mode window presents the basic parameters pertaining to a particular mode and allows their quick editing.

WORK SCHEDULE - CALENDAR

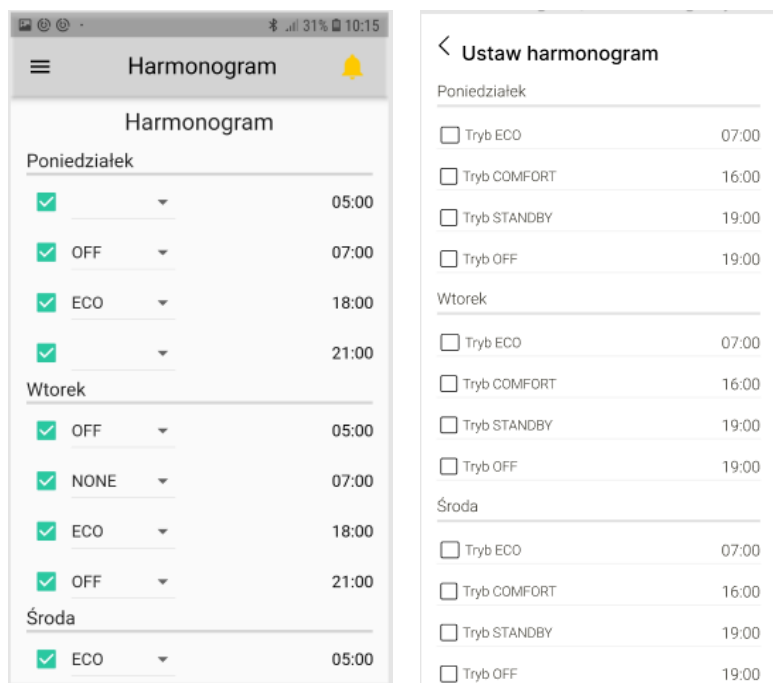

When you select the Schedule icon, there is an option:

- edit the days of switching on/off the control panel,
- Establish hourly intervals for the operation of the switchboard,
- mode assignment for a given time interval .

ALARMS



The list of alarms is visible under the icon 

Alarms can be opened in one of two views:

- Current alerts,
- Historical alerts.

The list of historical alarms shows a preview of alarms that are not currently active.

If there is a situation affecting to activate the alarm it will be shown in the list of active alarms. Then the application screen will turn red, to inform the user of the required response.

The "Reset" button clears all alarms on the screen - current and historical.

If there is an active alarm it will reappear in the current list.

FUNCTION SETTINGS - ADVANCED FUNCTIONS

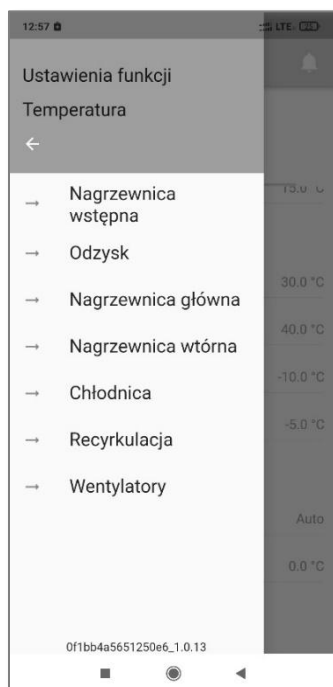

FUNCTION SETTINGS - this section of the menu gives you the ability to view and edit the operating parameters of the control panel related. In addition, you can access the control of individual inputs and outputs located on the control panel controller, as well as on the expansion board.

TEMPERATURE - The temperature settings section contains settings for all possible components that affect the resulting supply temperature.

FUNCTION SETTINGS - ADVANCED FEATURES (cont'd)

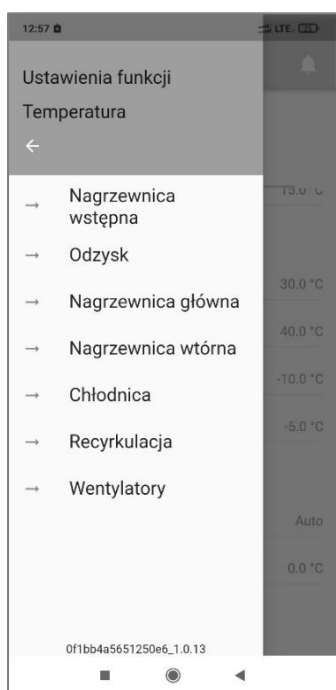

- **PRIMARY HEATER** - settings of preheater operating parameters, among others, PID, start and stop points (if available in the control panel).
- **RECOVERY** - parameter setting for the heat exchanger.
- **MAIN HEATER** - settings of operating parameters of the main heater (if available in the control panel).
- **SECONDARY HEATER** - settings of secondary heater operation parameters (if available in the control panel).
- **COOLER** - settings of operating parameters of the cooler (if available in the control panel).
- **RECYCLATION** - settings for the air recirculation function (if available in the control panel).
- **VENTILATORS** - settings for fan speed, PID algorithm, fan start and stop delay time, among others. CAV/VAV control.
- **MOISTURE** - possibility to set, among other things, PID parameters of the humidification process, extreme points for the start and end of humidification.

FUNCTION SETTINGS - ADVANCED FEATURES (cont'd)

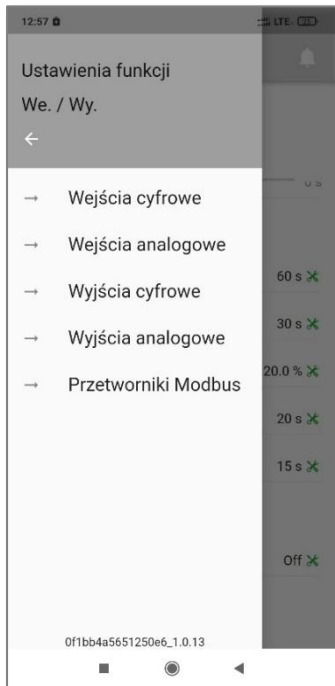

I/O. - Configurable inputs and digital and analog outputs and analog as well as ModBus signals. Inputs and outputs have been marked with the functions they are assigned to, e.g. DI1 - Fire alarm - is a digital input responsible for the fire alarm.

- Digital inputs,
- Analog inputs,
- Digital outputs,
- Analog outputs,
- Modbus transducers - ability to view and edit parameters related to transducers: pressure, humidity, CO2,

FUNCTION SETTINGS - ADVANCED FEATURES (cont'd)

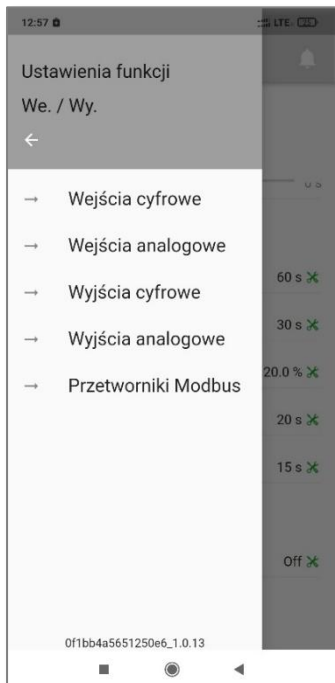

I/O EXPANSION MODULE

- Main board - allows you to read the parameters of signals connected to the main board of the control panel, activation/deactivation of the expansion board, as well as to set values such as : maximum pressure values, pressure offsets,
- EC PCB - it is possible to change the settings of inputs and outputs present on the PCB board
- HMI Basic - allows editing of settings related to the HMI Basic panel

UNIT

- Adjustment
- BMS - variables used in communication with BMS systems
- Access levels - there are 3 levels of access: user, service technician and manufacturer.

MONITORING

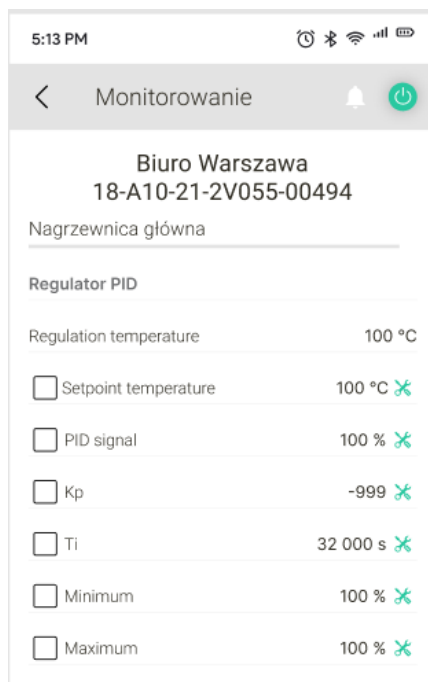

MONITORING

The user has the ability to define a quick view list of selected parameters.

To use this functionality, the user must save the selected parameters in the **MONITORING** section

APPLICATION SETTINGS

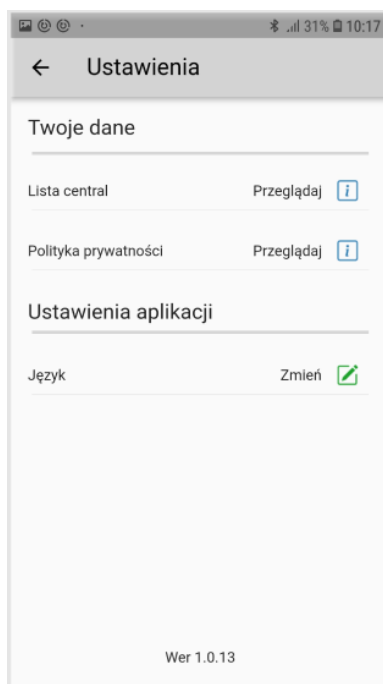
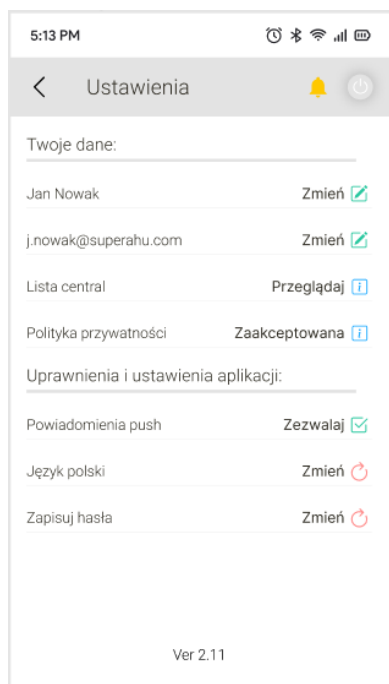

APPLICATION SETTINGS

Section of general settings that are not related to work parameters. Here it is possible to min:

- To give a custom name to the connected PBX,
- display a list of exchanges saved and currently detected by the bluetooth module,
- changing the language of the application,
- restore the factory settings of the control panel,
- Changes in display units for parameters.

7.2.7 OPERATING MODES OF THE CONTROL PANEL

OPERATING MODES OF THE CONTROL PANEL	
OFF	Air handling unit off - fans stopped, air dampers and control valves closed all sensors and measuring devices remain active - to protect the air handling unit from damage, such as fire alarm, anti-freeze protection.
AUTO	PBX operation dependent on calendar programming
LOW^{***}	Lower economy mode - Fan speed as well as dead zone in temperature control are adjustable. The temperature control algorithm can use a wide insensitive zone, while the fans can be set to low speed to reduce energy consumption.
COMFORT	Factory setting of selection parameters. The settings can be modified by the user.
HMI BASIC	Basic mode - external control signals (binary inputs) of critical temperatures, such as too low a temperature, causes the control panel to start and immediately heat the room.

^{***} - option not available in newer versions of uPC3 controller software

7.2.8 BASIC PARAMETER CONFIGURATION

- ! During the first commissioning, configure and adjust the operating parameters of the control panel, and configure and set the modes of operation of the control panel according to the nominal and preferred parameters ((by agreement with the user).
- ! It is also recommended to adjust the operating parameters of the device to the specifics of the object using, among other things, available PID controllers.

BASIC CONFIGURATION DURING INITIAL STARTUP

Application code configuration with consideration:

- The type and mode of operation of heat recovery,
- The type and parameters of the main heater,
- The type and parameters of the preheater,
- The type and parameters of the secondary heater,
- The type and parameters of the reversible system,
- parameters of the mixing chamber,
- Humidifier operating parameters (control of moisture content in the air),
- HMI Basic, HMI Basic2 occurrences,

Configuration and settings:

- leading sensor,
- type of temperature control,
- type of humidity control,
- type of supply fan control (CAV/ VAV),
- type of exhaust fan control (CAV/ VAV),
- type of supply fan motor controller (EC),
- type of exhaust fan motor controller (EC),
- PID controllers for fans and other functions found in the application,
- number of supply fans,
- number of exhaust fans,
- supply impeller size,
- Exhaust impeller size,
- supply capacity,
- exhaust performance,
- Displacement pressure of the supply,
- The disposable pressure of go exhaust,
- maximum speed for the supply fan motor,
- maximum speed for the exhaust fan motor,
- Activation of the water heater touch sensor,
- Activation of the humidity transmitter
- Activation of the CO2 transducer (VOC sensor),

BASIC CONFIGURATION - PROFILES (MODES) OF OPERATION

PARAMETER			JOB PROFILES			
			Comfort**	Optimum***	Economic	StandBy
			Comfort**	Low	Ekono	StandBy
Temperature	T	°C	VV	VV	VV	VV
Relative humidity - RH	RH*	%	VV	VV	VV	VV
Air quality - CO2 content	ppm	ppm	VV	VV	VV	VV
Supply capacity	V * _S	% m3/h	VV	VV	VV	VV
Exhaust capacity	V * _E	% m3/h	VV	VV	VV	VV

- Work profiles: Comfort, Optimum, Economic require setting the time and date of their validity in the calendar.
- StandBy operation profile - requires setting parameters:
 - StandBy time i.e. the minimum time for which the AHU is awakened in StandBy mode,
 - Wake-up time, i.e. the time that determines the interval between automatic wake-ups of the AHU in StandBy mode.
- * - humidity control requires the control panel to be equipped with humidification and dehumidification functions, otherwise the values are read only,
- ** - 100% means the efficiency from the selection sheet.
- *** - option not available in newer versions of uPC3 controller software

7.2.9 BASIC VERIFICATION OF OPERATION DURING INITIAL START-UP

During the initial startup, it is recommended to perform the steps listed below.

CHECKING THE OPERATION OF THE FANS

Check:

- That the fans do not make excessive noise (make sure the impeller does not rub against the hopper and there are no foreign bodies within the fans' operating range, which may be caused by improper transportation or storage conditions),
- That the impellers rotate in the correct direction (the geometry of the fans is designed to operate in a clockwise direction - when the motors start up, make sure they rotate in the right direction). Check the consistency of the direction of rotation with the arrow on the impeller.

CHECK THE OPERATION OF THE ROTARY EXCHANGER (IF ANY)

Check:

- whether the exchanger rotates without resistance in the right direction (the rotary exchanger wheel driven by a dedicated motor and the belt should rotate smoothly - in case of uneven operation or belt slippage, check whether foreign elements are blocking the exchanger movement or adjust the belt tension according to the relevant documentation)

CHECKING THE OPERATION OF AIR DAMPER ACTUATORS

- Check whether they close and open completely without resistance (this can be done by observing their operation during startup/shutdown of the control panel or by pressing the button on the actuator to release its locking mechanism and manually moving the laths),
- Check that they open and close in the correct direction (when the control panel startup sequence is started, the dampers should open, and when the control panel is turned off - check that they work in the correct order at the moment - the actuators are equipped with a button to change the direction of operation in case of wrong direction),
- For actuators with 0-10V signal, it is necessary to check whether they work correctly in the full range (0-10V actuators are always used for passive bypass of recovery and mixing chamber throttles - in the case of an air handling unit with a mixing chamber, in addition, the supply and exhaust throttle actuators can also be smoothly regulated by 0-10V voltage). - this can be done by observing its operation during the operation of the air handling unit, or manually giving the control signal to the appropriate screens of the mixing chamber or recovery controller (set D to ON and A to the selected percentage value).



```

S Mixing Damper E01
Eco damper
CONTROL SIGNALS
→Manual D AUTO A AUTO
  
```



```

S Recovery D01
Recovery device
CONTROL SIGNALS
→Logic ~ Off NC
→Manual D AUTO A AUTO
COUNTER
→Hours 0h
→Reset NO
  
```

CHECKING SENSOR READINGS

- check that the readings from temperature, pressure, CO2 and humidity sensors are correct (at the beginning, when the air handling unit is powered but not running, the temperatures sent to the controller from the temperature sensors should oscillate in the range of ambient air temperature of the air handling unit, while the other transducers and sensors should show values typical for the environment - for example, most often for the CO2 sensor will be values below 600ppm for fresh air and initially zero values of flow and pressure before starting the fans on the pressure of the transducers, their values should change accordingly within the expected range once the unit is set up for operation).

I/O status Sc01	
Temperatures	
B1 Supply	0.0°C
B2 Return	0.0°C
B3 External	0.0°C
B4 Recovery	0.0°C
B5 Water heat	0.0°C

I/O status Sc02	
Temperatures	
B6 Rec. Supply	0.0°C
Water preheat	0.0°C
After preheat	0.0°C
TH Room	0.0°C

I/O status Sc03	
Humidities	
Room	0.0%rH
Supply	0.0%rH
Return	0.0%rH

I/O status Sc04	
Pressures	
Supply	0.0Pa
Return	0.0Pa

I/O status Sc05	
Return CO2 value	0.0PPM

I/O status Sc38	
Pressure filters	
SUPPLY	0.0Pa
SUPPLY 2	0.0Pa
SUPPLY 3	0.0Pa
Return	0.0Pa
Return 2	0.0Pa

CHECKING THE OPERATION OF WATER HEATER VALVE ACTUATORS

Check whether the actuator of the heater valve responds to the control signal - manually set the valve from the service menu of the controller and observe whether it causes the valve to open / close, respectively. To do this, set parameter D to ON and parameter A to the selected percentage on the corresponding screen in the service menu, depending on the type of heater you have and the function it performs [screens A01, A03, A05, A06. (See "UPC3 CONTROLLER MASK DESCRIPTION")

CHECK THE OPERATION OF THE WATER HEATER CIRCULATION PUMP

Check whether the heater circulating pump responds to the control signal - manually set the valve from the service menu of the controller and observe whether it causes the pump to switch on/off accordingly.

! Be sure to restore the original settings of the D and A (Auto) parameters after the test is performed

7.3 REGULATION

7.3.1 HEATING CONTROL OF THE WATER HEATER

Heater power control is determined by the amount of air flowing through the air handling unit. Power adjustment involves checking the operation of the heater by measuring the temperature on the inlet side of the supply air, and the outlet side of the heated air, at the designed values of supply and return temperatures and the amount of heating medium in the system.

The power of the heater is controlled by regulating the temperature of the circulating water. This is achieved by mixing high-temperature feed water and return water in a three-way valve from the heater. After mixing, the water entering the heater has the appropriate temperature - depending on the level of mixing.

Verification of the operation of the antifreeze thermostat is possible only when the supply air temperature to the exchanger is lower than the thermostat setting (factory setting (+5)° C. In order to properly verify the functioning of the thermostat, the check should be made when the supply air temperature is 1÷ 2 degrees higher than 0° C. Then, when the air handling unit is running, interrupt the supply of the heating medium for a while and observe whether the thermostat is activated. This operation should be performed before returning the air handling unit to normal operation.

7.3.2 ADJUSTMENT OF THE ELECTRIC HEATER

Control of the power of the electric heater is mostly carried out by switching off an individual group of heating coils. Multistage control is carried out by connecting specific heating modules to each other. Smooth control of the power of the heater is carried out by the VTS control module.

Simulate a lower power requirement by decreasing the temperature setting so that all electric stages (switches) are in the off position. Then increase the temperature setting significantly and check that all electric stages turn on in the order of operation as described. Restore the previous temperature setting.

Also check the operation of the overheating protection in the absence of air flow. To do this, reduce the flow of air passing through the heater by pressing on the inlet damper or reducing the speed of the fan.



- ! During operation of the air handling unit, the speed of air flowing through the heater should not be less than 1.5 [m/s].
- ! Note that the lower the airflow, the more it is possible to overheat the system. Putting the unit down must involve a certain delay (0.5-5.0 minutes) to cool down the individual electric heater modules.

7.3.3 CAPACITY CONTROL OF THE COOLER

Adjustment of the capacity of the cooler should be carried out under conditions similar to those, under which the device will operate. As with the heater, the effect of air parameters, including temperature and humidity on the inlet and exhaust sides of the cooler, is taken into account.

The temperature of the refrigerant is also controlled in this way.

If the cooling effect is not satisfactory, appropriate adjustment is required. It can be carried out by the following methods:

- Regulation of the amount of cooling medium or/and supply temps (water coolers),
- regulation of the amount of air passing through the air handling unit (water cooler and coolers with direct evaporation of the medium),
- Control by changing the evaporation temperature (for systems with direct evaporation).

The coolers operate in most cases in complex air-conditioning systems with automatic controls. Automatic controls should be tested not only under extreme conditions, but also under intermediate load conditions of the cooler.

7.3.4 CONTROL OF THE EVAPORATIVE HUMIDIFIER (WITH ADIABATIC EVAPORATION)

Water flow must be adjusted to the humidifier. The water demand must be adjusted to the specific control panel, so that the bed surface is thoroughly humidified.

Table 11 shows the minimum and nominal water flow rate for the standard operating point:

- Inlet air temperature 40° C,
- relative humidity 15%

air velocity in the humidifier bed 2.5 [m/s]

Size of the device	Min. amount of water [liter/min].	Size of the device	Min. amount of water [liter/min].
VVS021	0,54	VVS230	5,03
VVS030	0,79	VVS300	6,79
VVS040	0,97	VVS350	9,64
VVS055	1,49	VVS400	9,64
VVS075	1,68	VVS450	11,27
VVS100	2,24	VVS500	11,27
VVS120	2,71	VVS575	15,26
VVS150	3,31	VVS650	15,26
VVS180	4,16		

7.4 THE MOST COMMON ADAPTIVE CHANGES OF PARAMETERS TO THE NEEDS OF THE FACILITY

FUNCTION	SCREEN	SCOPE OF CHANGE	WHEN TO CHANGE
MAIN HEATER	A07	PID	unstable temperature control
DXH MAINTAIN	A11	compressor switch-on thresholds	unstable temperature control
SECONDARY HEATER	A12	PID	unstable temperature control
PREHEATER	A16	PID, set temp. after heat, min/max power	unstable temperature control
MAIN RADIATOR	B03	PID, min/max power	unstable temperature control
DX MAINTAINER	B05	compressor switch-on thresholds	unstable temperature control
VENTILATORS	C16	PID	unstable temp control.
VENTILATORS	C16	setting of efficiency dependence on reg. temp.	matching object properties
RECOVERY DEVICE	D02	PID, min/max power	unstable temperature control with heat recovery
RECOVERY DEVICE	D03	PID	Unstable temperature control with cooling recovery
MIXING CHAMBER	E02	PID in the heating direction	Unstable temp. control with inefficient heat source
MIXING CHAMBER	E03	PID in the cooling direction	Unstable temp. control with inefficient heat source
GENERAL	H01	temp. min/max, temp. min/max setting	matching object properties
VENTILATORS	H02	PID dependence of performance on reg. temp.	unstable performance regulation from temperature
GENERAL	H03	heating/cooling switching thresholds	unstable temperature control
GENERAL	H04	"StdBy" mode parameters	matching object properties
GENERAL	I02	choice of leading temp.	matching object properties
N FANS	C07	PID`	unstable capacity regulation
VENTILATORS W CO2	C08	PID	unstable capacity regulation
VENTILATORS	C12	PID	unstable co2 regulation by changing output
VENTILATORS	C12	setting of efficiency dependence on CO2 reg.	matching object properties
MIXING CHAMBER	E04	PID	unstable co2 control by changing recirculation
MIXING CHAMBER	E06	parameters of the "rapid heating" function	matching object properties
NAVIGATOR	F02	PID	unstable humidity control
COMPOUND HUMIDIFIER	F03	humidifier on/off threshold	unstable or not very precise humidity control
GENERAL	I02	choice of leading v.	matching object properties
HMI BASIC	I05	sensor activation in HMI Basic	matching the needs of the facility
DXH MAINTAIN	A10	compressor run time setting	
DXH INTRODUCTION	A14	compressor run time setting	
DXH INTRODUCTION	A18	compressor run time setting	
AHU	A21	next min. air temp. and shutdown delay.	object sensitive to low supply temp.

FUNCTION	SCREEN	SCOPE OF CHANGE	NOTES
PREHEATER	A29	Support for heating the supply air	object sensitive to low supply temp.
AHU	A21	next min. air temp. and shutdown delay.	object sensitive to low supply temp.
DX MAINTAINER	B04	compressor run time setting	
VENTILATORS	C11	fire settings	matching object properties
RECOVERY DEVICE	D06	set. share of defrosting methods	Lack of heat source power supply or object sensitive to reduction of supply capacity
NAVIGATOR	G08	humidifier alarm - logic	matching the properties of the humidifier
DIGITAL INPUTS	G07	fire entrance.	matching the characteristics of the fire system.
DIGITAL INPUTS	G07	heating, cooling alarm	matching the properties of the foreign heating/cooling source
DIGITAL OUTPUT	G09	collective alarm logic	matching the needs of the facility
REC. MAIN ELECTR.	A09	setting the power distribution of the heaters	configuration setting
RECORD. ELECTR.	A13	setting the power distribution of the heaters	configuration setting
RECORD. PRE ELECTR.	A17	setting the power distribution of the heaters	configuration setting
DXH	A22	aggregate control signal scaling	matching the characteristics of the cooling source
DXH	A23	set min. temp. ext.	matching the characteristics of the cooling source
VENTILATORS	C05	Set. type. of. vent. and. nominal. capacity.	
VENTILATORS	C06	Pressure setting for VAV controllers	customization of VAV controllers
RECOVERY DEVICE	D03	activation of cooling recovery	
MIXING CHAMBER	E05	min/max working range setting	min - need for minimum air exchange in the facility, max - installation of intake and exhaust less than N and W
MIXING CHAMBER	E07	set. working method for each profile	matching the needs of the facility
STEAM HUMIDIFIER	F01	ustw. logic of operation, check for correctness	humidifier from outside the VTS offer
DIGITAL INPUTS	G08	Remote AHU profile setup (set profile type and NC/NO logic)	matching the requirements of the facility
DIGITAL INPUTS	G08	input logic. External summer/winter mode override	matching the requirements of the facility
DIGITAL OUTPUT	G09	logic on glycol recovery pump.	matching the control characteristics of the glycol pump
DX, DXH	G10	logic outputs on I and II heating/cooling stage.	matching the characteristics of the cooling source
NAVIGATOR	G11	logic of exit. work permit	matching the properties of the humidifier

FUNCTION	SCREEN	SCOPE OF CHANGE	NOTES
RIBBON HEATER	G11	logic of exit. work permit	matching the properties of the heater
SECONDARY HEATER	G11	logic of exit. work permit	matching the properties of the humidifier
TRANS. VENT. REDUN.	G11	logic of exit. work permit	Matching the properties of control. culvert.
PROCESS. PRESS. FILTERS	G18	activation of transducers	additional air filters
ADDITIONAL FILTERS.	G20	filter type	additional air filters
ADDITIONAL FILTERS.	G21	max. pressure drops.	additional air filters
CONTROLLER	I02	progr./work mode switchover	AHU configuration change, first startup????
VENTILATORS	I03	type of regulation CAV/VAV/none	matching the properties of the ventilation system.
HMI BASIC	I05	allow. alarm reset from HMI Basic	adaptation to user requirements
CONTROLLER	I11	export/import of controller settings	Parameterization of several of the same AHU, archiving of settings
HMI BASIC	J03	activation, address	
FILTERS	J09	type, max. pressure drop	Changing the type of filter, adjusting to the needs of the object
VENTILATORS	J11, J12	set. control. External analog signal	adaptation to the needs of the facility
HMI, PLC	I06	selection of schedule source (Basic/uPC/none)	customization
ACCESS LEVEL.	K01	logout	end of setting change
AHU	Sa01	preview of current AHU utility pairs	
AHU	Sa03 to S07	changes in settings of current parameters	current needs of the facility
HMI	Sa08	setting the date and real time	
HMI	Sa09 to Sa11	setting the work schedule	customization
TEMP.	G05	B1 and B3 calibration	cable length > 5 m

8 MAINTENANCE AND INSPECTION



- ! Personnel responsible for operating the control panel should read the documentation before starting any operations and maintenance activities. In the absence of such personnel with appropriate skills and competence, periodic inspections should be carried out by authorized VTS service providers.
- ! The basic technical data of the air handling unit, such as the type, parameters and dimensions of the most important components (filters, heat exchangers, fans, electric motors), can be found in the technical data sheet, which is supplied with each unit.
- ! All maintenance on air handling units should be carried out with the unit turned off.
- ! To ensure safe operation of the unit, the service switch, which cuts off power to the motor during maintenance work, must be installed outside the fan section. Disconnection of the power circuit with the service switch must be done in a de-energized state. The service switch should be located near the inspection panels of the fan section.
- ! It is essential to carry out thorough and regular maintenance work as well as technical inspections of air conditioning units and their components to identify faults at an early stage of their occurrence - before more serious failures and damage occur.
- ! This documentation covers only general guidelines for inspection periods to ensure trouble-free operation of air handling units under various possible external conditions for their operation. Technical inspection periods must be adapted to local conditions (level of contamination, number of start-up cycles, loads, etc.).

Thorough and regular maintenance and technical inspections of the control panel and its components are necessary to find failures at an early stage, before more serious damage occurs.

When contacting a VTS representative, always use the factory number of the AHU, located on the casing, as well as on the air conditioning unit.

The intervals between operations have been determined, assuming that the air handling unit operates continuously in low dust conditions and without any other factors that aggravate the unit's operating conditions. In environments with high levels of dust in the supply or exhaust air, inspections should be carried out more frequently.

8.1.1 MULTI-BLADE AIR DAMPERS

MULTI-BLADE AIR DAMPERS

If the throttle is dirty and does not work freely, clean it according to one of the following methods:

- Using a vacuum cleaner with a soft suction nozzle,
- By blowing with compressed air,
- Washing water and non-corrosive cleaning agents for aluminum.

After reinstallation, the damper should be carefully sealed, primarily on the outside air intake side, to prevent the water heater from freezing.

8.1.2 AIR FILTERS

AIR FILTERS

- Under standard operating conditions of air conditioning units, filters should be replaced approximately twice a year. The need to replace the filter (in addition to visually visible contamination) is also demonstrated by a drop in pressure:
 - Coarse 80% - 150Pa,
 - ePM10 40% - 250 Pa,
 - ePM2.5 65% - 250 Pa,
 - ePM1 80% - 350 Pa,
 - HEPA - 600 Pa
- If the final pressure difference exceeds the design value, the filter must be replaced. Filters are disposable components.
- When replacing the filter, the filtration section should also be cleaned - with a vacuum cleaner or by dry cleaning.
- The level of filtration can vary depending on the type of filter, so it is very important to install the same type and grade of filter as the original filter.
- Air handling units must always operate with air filters installed; their absence can result in unexpected damage to the unit.



- ! Incorrect, improperly installed filters, soggy or dirty filters can damage the device.
- ! Incorrectly installed filters, damp or dirty filters can cause an increase in the power consumption of fan motors.
- ! Do not allow the unit to operate with filters that have reached maximum air resistance.

8.1.3 WATER AND GLYCOL HEATER

WATER AND GLYCOL HEATER

- Active water heaters should be equipped with anti-freeze systems. As an option, a non-freezing heating medium (e.g., glycol solution) can be used in winter. If the heating medium supply is cut off or the air handling unit is stationary, and if the air temperature is likely to fall below + 5° C, the heater should be drained. For this purpose, it is necessary to:
 - close the heating medium inlet and outlet valves (cut off the heater from the heating system),
 - Remove the inspection panel,
 - Unscrew the drain and remove the vent plug from the collectors,
 - connect the output hose to the drain, allowing water to run off the evacuated exchanger outside the unit,
 - Blow out the heater with compressed air, introduced through the vent plug,
 - repeat this procedure several times in short intervals until the air coming out of the drain hose shows no visible water droplets,
 - Screw the drain plug and vent plug back in.

- Check the level of dirt on the heater plates at least once every four months. The settlement of dust on the surface of the heater causes a deterioration of its heating power and leads to a decrease in air-side pressure. Even if the air handling unit is equipped with filters, over time dust, supplied with the supplied air, settles on the heater plates. If the plates become dirty, their cleaning should be carried out in one of the following ways:
 - Using a vacuum cleaner with a soft suction nozzle on the air inlet side,
 - by blowing with a jet of compressed air against the direction of normal air flow, directing the jet parallel to the plates,
 - Washing with warm water with cleaning agents that do not cause corrosion of aluminum or copper components.
- Before washing, protect adjacent sections of the air conditioning unit from contamination.
- To achieve maximum heating capacity of the heater, it must be well vented. For this purpose, vent plugs have been designed, located on the heater manifolds.
- When the air handling unit is stationary, the flow of the heating medium should be limited to a minimum, so that the temperature inside the air handling unit does not exceed +60° C. Exceeding this value could cause damage to some components or subassemblies (motor, bearings, plastic parts, etc.), installed in adjacent sections.
- For full thermal efficiency of the heater, it must be well vented. For this purpose, vent plugs located in the heater manifolds are used.

8.1.4 WATER AND GLYCOL COOLER

WATER AND GLYCOL COOLER

- The state of dirt on the cooler should be checked every four months. If necessary, the cooler can be cleaned using the methods described for water heaters. Before cleaning, adjacent sections of the air handling unit should be protected. When inspecting the dirt condition, also check the cleanliness of the condenser and the patency of the condensate tray drain and the patency of the water trap. The water trap should be flooded with water before starting the air handling unit. If contaminated, the condenser should be washed with warm water with detergent. For a glycol cooler, additionally check the content and density of glycol in the circuit. For full thermal efficiency, the cooler must be well vented. For this purpose, vent plugs located in the radiator manifolds are used.

8.1.5 ELECTRIC HEATER

ELECTRIC HEATER

- The electric heater battery consists of bare heating coils. During the operation of the air conditioning unit, when the heater is turned off, dust may settle on the heating coils. When the heater is restarted, heavy contamination of its surface can generate unpleasant odors of burning dust, even leading to an initial fire hazard.
- Check regularly, (every 4 months), and especially before the start of the heating season, all electrical connections, the condition of the heating elements and their level of contamination. Any dirt should be removed with a vacuum cleaner with a soft tip or compressed air.
- The operation of the overheating protection system in the absence of air flow should also be checked. The speed of air flow should not be less than 1.5 m/s.



! WET CLEANING OF ELECTRIC HEATERS IS PROHIBITED

8.1.6 DX (FREON) HEATERS AND COOLERS

DX (FREON) HEATERS AND COOLERS

- Maintenance of the freon heater and cooler includes the same range of activities as maintenance of the water heater and cooler. Before washing the freon cooler with warm water, the cooling system should be emptied by draining the freon into a container. Otherwise, there will be a risk of uncontrolled increase in freon pressure, causing damage to the cooling system.

8.1.7 EVAPORATIVE HUMIDIFIER

COMPOUND HUMIDIFIER

- Periodic maintenance of the humidifier is reduced to cleaning the mesh filter on the humidifier supply at least 4 times a year, and at least once a year you should check: the condition of the electrical wires whether they have not aged, rubbed, etc.; the condition of the water system and connectors whether leaks have not appeared, whether the water pump does not make unusual sounds.

SUBJECT	PERIOD	WHAT:
Preparation		<ul style="list-style-type: none"> • Turn off the power and water supply.

Washing the percol filter element of the "Y" model.	Every 6 months	<ul style="list-style-type: none"> • Unscrew the percolator and remove the filter element, wash the filter element with clean water and reinstall it.
Checking the wiring	Once a year	<ul style="list-style-type: none"> • Check all electrical wiring and cables for signs of aging insulation, current leakage, etc. Check the stability. If the above symptoms occur, replace the parts immediately. • Check all water humidifier wiring and plumbing connections. If the above-mentioned cases occur, replace or repair immediately.
System control (circulating water)	Once a year	<ul style="list-style-type: none"> • Check for unusual sounds or strange odor when the pump is running (check once a month).
	Once a month	<ul style="list-style-type: none"> • Check the attachment of the water pipe connection. • Check for water leakage.
Overview of the main engine	Once a year	<ul style="list-style-type: none"> • Check for unusual sounds or strange odor when the pump is running (check once a month).
	Once a month	<ul style="list-style-type: none"> • Check the operation of the controls once a year
Checking the electrical insulation	Once a year	<ul style="list-style-type: none"> • Dielectric strength > 500V, insulation resistance > 10MΩ

8.1.8 HEAT RECUPERATOR (COUNTERFLOW, HEXAGONAL, CROSSFLOW)

HEAT RECUPERATOR (COUNTERFLOW, HEXAGONAL, CROSSFLOW)

Maintenance of the heat exchanger is reduced to checking its technical condition and the degree of dirt on the aluminum plates, once every 4 months. The accumulation of dirt in heat exchangers is often limited to the first 50 mm in the exchanger. Before cleaning, protect adjacent sections.

The necessary cleaning should be done by one of the methods by:

- vacuuming with a soft squeegee,
- blowing the ducts with a stream of air in the direction opposite to the normal air flow,
- washing along the entire length of the air ducts with water and non-corrosive cleaning agents for aluminum,
- for more dirty exchangers can be cleaned by rinsing with a high-pressure water jet.

During cleaning when using mechanical dirt removers, be very careful, and make sure that the exchanger plates are not deformed or damaged. When operating the exchanger in freezing temperatures, the exchanger must be thoroughly dried before restarting the air handling unit.

Check:

- throttle action,
- condenser condition,
- the state of drainage of the factor from the tray,
- ease of condensate drainage,
- fill the U-TRAP with water before starting the control unit,
- anti-freeze system, (if any),

PROCEDURE FOR EXTRACTING THE EXCHANGER FROM THE AIR HANDLING UNIT

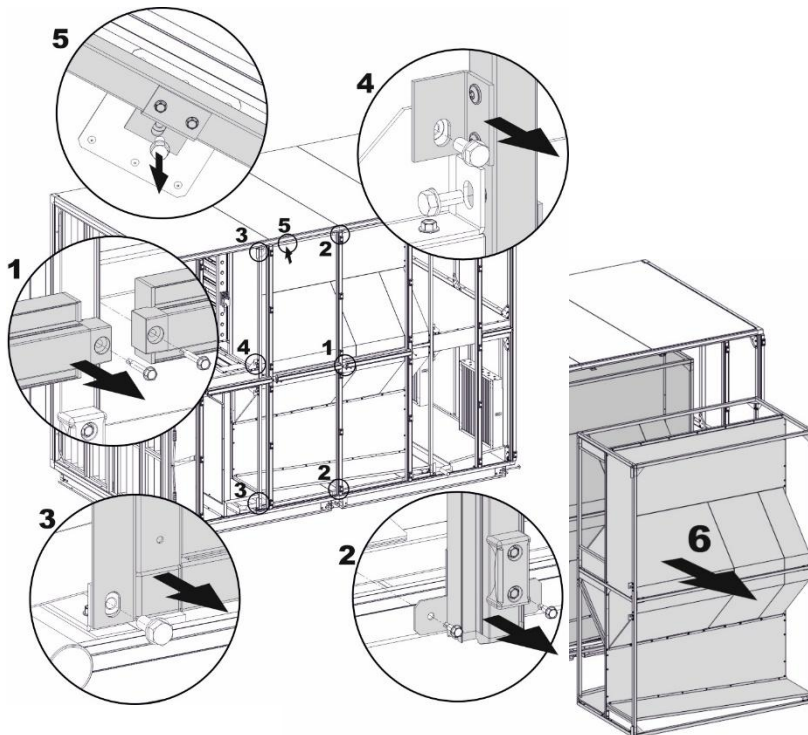

Unscrew the screws holding the horizontal columns (item 1) and remove them.

Loosen the screws securing the vertical columns at the top and bottom (item 2) and remove them from the device.

Remove the screws that secure the exchanger cage. The screws are located on the top and bottom (item 3), and the middle part of the exchanger (item 4).

The VVS075-230 units include an additional ceiling mount (item 5).

Remove the exchanger cage from the AHU (item 6).

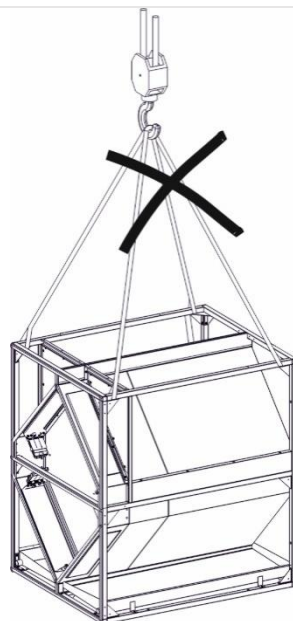

The number of columns, screws and bolts needed for disassembly depends on the size of the unit.

The cages of the counter-current heat exchanger must not be lifted by a crane using the upper profiles of the structure. They should be supported from below.

In VVS021-VVS055 units, the counterflow heat exchanger is installed as a single component, like a cross-flow recuperator, and can be accessed directly by opening the inspection panels. In the VVS075-VVS150 units, the hexagonal exchanger is built vertically and consists of one, two or more elements assembled in a separate structure. Each of these structures is removable from the air handling unit.

8.1.9 ROTARY EXCHANGER

EXCHANGER ROTARY

- When performing maintenance on the rotary exchanger, check that:
 - The rotor rotates freely. Excessive resistance may be caused by the sealing brushes being pressed too far against the edge of the rotor. In such a situation, adjust the brushes accordingly. A worn seal should be replaced. If a previously removed seal is to be reinstalled, install it so that its direction is in line with the rotor's direction of rotation. After replacing or adjusting the sealing brushes, the exchanger should run for 30 minutes to allow the brushes to adjust to the rotor surface.
 - After that, check:
 - motor current and compare it with the rated current to find out whether the motor is overloaded.
 - That the drive belt is not damaged and clean, and that it does not slip on the cylindrical part of the rotor. If belt slippage still exists despite the maximum tension of the tensioning system, the belt should be replaced or shortened,
 - That the air inlet holes are not covered with dust or contaminated in any other way
in any other way. Remove any contamination with a vacuum cleaner with a soft tip or compressed air.
- The rolling bearings of the rotor and drive motor are lubricated continuously during operation. The amount of grease in the bearings during the installation of the exchanger is sufficient for long-term operation, and there is no need to lubricate the bearings during operation. It is recommended that the motor and gearbox be cleaned of dust so that an insulating layer does not form on the surface of the motor, which can lead to an increase in the operating temperature of the drive.
- This exchanger should be inspected, every four months, and the inspection should cover the technical condition as well as the level of impurities. The accumulation of dirt in the heat exchanger fins is often limited to the first 50 mm in the exchanger. Before cleaning, adjacent sections of the air conditioning unit should be protected from contamination.
- The necessary cleaning should be carried out as follows:
 - Using vacuum cleaners with a soft suction nozzle,
 - By blowing the ducts with a stream of air in the opposite direction to the direction of normal air flow,
 - Washing the air ducts along the entire length with water with cleaning agents that do not cause corrosion of aluminum,
 - In the case of very dirty exchangers, a stream of pressurized water can be used to clean them.
- When cleaning the exchanger with mechanical means, pay maximum attention not to damage or deform the exchanger panels.
- When operating the exchanger in sub-zero temperatures, it must be thoroughly dried after washing before restarting.
- Inspection and maintenance of the rotary exchanger drive must be carried out
At the following intervals:
 - 12 hours after launch,
 - 1 week after launch,
 - at least, every 3 months

8.1.10 SOUND ATTENUATORS (DAMPING SPHERES)

SOUND ATTENUATORS (DAMPING BAFFLES)

The muffler section is equipped with baffles made of non-combustible mineral wool to absorb acoustic energy. Maintenance procedures include checking the dirt level of these baffles and vacuuming them if necessary. It is also necessary to check for damage to the damping baffles. If damage is identified, the baffles should be repaired or replaced.

8.1.11 FAN UNIT

FAN UNIT



- ! Before performing any work (repair, maintenance, service) on the air handling unit, especially when opening inspection panels in the fan section, as well as when removing covers over the drive system, make sure that:
- the device has been properly disconnected from the power supply. this applies to both primary and secondary circuits,
 - the rotor does not rotate,
 - the fan surfaces are cool and temperature-safe to the touch,
 - the fan is protected against unintentional start-up

8.1.12 FAN SETS

The fans are designed for dust-free or lightly dusty air flow. They are not designed to operate with aggressive gases, vapor or in highly dusty environments. Operating fans in unsuitable environments can lead to bearing damage, corrosion, rotor imbalance or vibration.

The fan and motor of the unit are provided to meet special requirements and for special operating characteristics. The fan speed is set so that the airflow and total impeller stress concentration are appropriate for the ventilation system. A lower forced air flow causes operating disturbances and leads to a loss of balance of the entire ventilation system. This can be caused by:

- drive belt slippage,
- dust deposition on the fan impeller blades,
- wrong direction of fan rotation.

If the radial fan rotates in the wrong direction, the air flow causes significantly harmful effects.

- When performing maintenance on a fan, check that:
 - the impeller rotates freely, - the rotor is properly balanced,
 - the impeller is securely fastened to the journal,
 - has not changed position relative to the inlet cone,
 - all screws securing the structural components of the fan are tightened,
 - the rotor has no run-out, no imbalance, and that all balancing weights are in their original place. The impeller imbalance can be caused by:
 - dust deposition on the rotor blades,
 - detachment of additional balancing weights,
 - rotor blade damage.
- The contamination level of the inside of the fan section casing, impeller and motor casing should be checked. This should be carried out every four months. If necessary, carry out cleaning by vacuuming or wiping all surfaces with a wet cloth:
 - the inside of the casing with a vacuum cleaner,
 - impeller with a vacuum cleaner and by damp wiping with a cloth dampened in a soft cleaning agent.

For more serious dirt, you can do with nylon brushes.

- The bearings should be inspected. A prerequisite for the expected service life of the fan is regular inspection and cleaning of bearings. The bearings of the fan should be inspected, on the occasion of maintenance activities.

Turning the fan rotor by hand, carry out an auditory check of the bearings. If it is heard:

- a not very loud sound accompanying turning in the form of a quite soft, steady murmur,
 - proper operation of the bearing,
 - rasp,
 - lubrication is inadequate,
 - hard, often irregular noises, scrubbing or metallic, often repeated sound,
 - the bearing may have been damaged. The bearing should be replaced.
- Check the temperature of the bearing with a thermometer or by putting your hand on its casing. If the temperature is too high or changes rapidly, this indicates a malfunction of the bearing, the cause of which may be:
 - lack or excess lubricant,
 - dirty, overloaded or damaged bearing balls,
 - bearing compression,
 - too much gasket friction,
 - external heating.

THE INCREASE IN TEMPERATURE IS NORMAL DURING THE FIRST 1-2 DAYS AFTER LUBRICATION.

During proper operation, fan bearings of VVS021-VVS650 air handling units do not require lubrication. Fan bearings without belt-driven casing are equipped with grease nipples. In this case, the bearings should be lubricated with solid bearing grease, at intervals depending on the intensity of operation of the air handling unit and the current technical condition of the bearing. It is recommended to lubricate, every 9 months, the operating temperature of the air handling unit not higher than 50° C, and for higher temperatures every 4 months. The amount of grease used to lubricate the bearings depends on the size of the fan and the bearings used in it. Excess grease in the bearing casing causes the bearing temperature to rise, especially at high fan speeds. After several lubrications, open the bearing casing and remove the old grease before adding new grease.

RECOMMENDED LUBRICANTS FOR BEARINGS			
BRAND	TYPE	TYPE	OPERATING TEMPERATURE RANGES (MIN/ MAX)
FINA	Marson HTL 3	Lithium	(-30)°C / (+120)°C
SHELL	Alvania Fett 3	Lithium	(-20)°C / (+130)°C
ESSO	Beacon 3	Lithium	(-20)°C / (+130)°C
MOBIL	Mobilux EP3	Lithium	(-30)°C / (+130)°C
SKF	LGMT 2/S	Lithium	(-30)°C / (+110)°C
FINA	Marson HTL 3	Lithium	(-30)°C / (+120)°C

8.1.13 FAN BEARINGS (AC)

Depending on the type, size and shaft power, fans installed in the air handling units are equipped with different types of bearings. Fans without casing with belt drive of the PEAFF..KBT version are supplied with greased ball bearings in cast iron casing. The amount of grease used for lubrication, as well as the lubrication interval, depends on the type of bearing and its speed. Replacement of bearings mounted in individual cast iron casing in fans of type PEAFF...KBT 1

REPLACEMENT OF BELT DRIVE FAN BEARINGS PEAFF..KBT 1 VERSION

- Loosen the retaining screws 1 and remove the retaining rings 2 from the bearings using a punch and hammer. Remove the cotter pins 3 from the cast iron bearing casing and loosen the screws 4 securing the casing. Slide the casing together with the bearing off the shaft. Using appropriate jigs, support the shaft in the correct position so as not to damage the inlet funnel or rotor wheel.
- Replace bearings by installing new ones in cast iron casing.
- Mount the casings on the frame, being careful to ensure the concentricity of the rotor and inlet cone. Tighten the screws securing the casings. Attach the retaining rings to the bearings by clamping them according to the direction of rotation of the fan and secure them with set screws. Spin the wheel to check that it rotates properly.

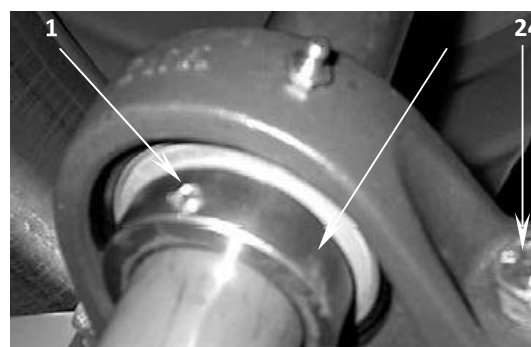

ROLLING BEARINGS OF THE FAN WITH BELT DRIVE VERSION PEAFF..KBT 1

AHU	FAN TYPE	BOTTOM [mm].	INA		SKF	
			BEARING UNIT TYPE	BED TYPE	BEARING UNIT TYPE	BED TYPE
VVS 180	PEAF 630 KBT 1	40	PASE 40	GRAE 40 NPPB	SY 40 FM	YET 208
VVS 230	PEAF 710 KBT 1	50	PASE 50	GRAE 50 NPPB	SY 50 FM	YET 210
VVS 300	PEAF 800 KBT 1	50	PASE 50	GRAE 50 NPPB	SY 50 FM	YET 210
VVS 400	PEAF 900 KBT 1	60	PASE 60	GRAE 60 NPPB	SY 60 FM	YET 212
VVS 500	PEAF 1000 KBT 1	60	PASE 60	GRAE 60 NPPB	SY 60 FM	YET 212
VVS 650	PEAF 1120 KBT 1 (inlet funnel side)	60	PASE 60	GRAE 60 NPPB	SY 60 FM	YET 212
VVS 650	PEAF 1120 KBT 1 (belt transmission side)	60	RSAO 60 FA 106	GNE60-KRR-B	-	-

REPLACEMENT OF BEARINGS MOUNTED IN THE CROSS FRAME OF THE FANS TAE TYPE

- Remove the retaining screws (1) and remove the retaining rings (2) from the bearings using a center punch and hammer. Slide the retaining rings off the shaft. Using the appropriate tools, hold the shaft in the correct position so as not to damage the inlet funnel or rotor.
- Detach the crossbars (3) from the side panels and slide them off the shaft along with the bearing. Remove the old bearings and rubber rings and fit the new bearings and rubber rings on the brackets.
- Install the casings on the frame, taking care to ensure the concentricity of the rotor and inlet cone. Tighten the screws securing the casings. Install retaining rings on the bearings clamping them according to the direction of rotation of the fan and secure them with setscrews. Spin the wheel to check that it rotates properly.

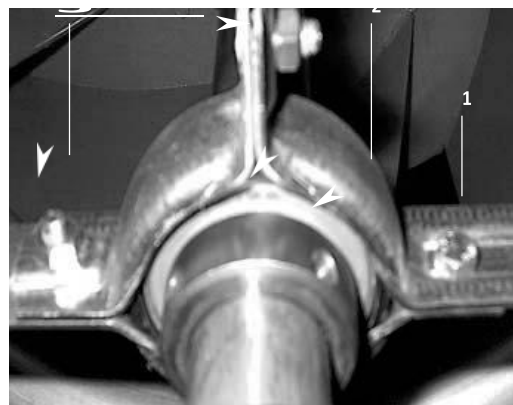

REPLACEMENT OF BEARINGS MOUNTED IN THE CROSS FRAME OF THE FANS TDF TYPE

- Unscrew the lock washer (1) with a screwdriver and unscrew the nut (2).
- Knock out the inner bushing (3) with a copper hammer and remove the screws (4) holding the casing. Slide the casing together with the bearing from the shaft. Using appropriate tools, immobilize the shaft in the correct position to not damage the inlet funnel or rotor.
- Replace the bearings, installing the new ones in the cast iron casing (note that the inner diameter of the bearing is conical, and the bearing should be mounted with a larger diameter on the fan rotor side).
- Attach the casing to the frame, paying attention to the concentricity of the rotor and input hopper. Tighten the mounting screws of the casing. On the funnel side, slide the bushing on the shaft beforehand using a copper hammer. Install the safety device. Then rotate the shaft to check that it rotates properly.

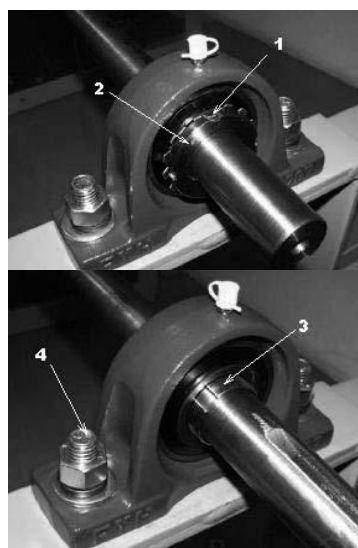

FAN BEARINGS FOR TAE / TDF TYPE CASING					
AHU	FAN TYPE	SHAFT [mm]	PEER/FVH		
			BEARING UNIT TYPE	BEARING CASING TYPE	BED TYPE
VVS021	TAE160/D	12			FH204 -12G
VVS030	TAE200/D	12			FH204 -12G
VVS040	TAE225/D	12			FH204 -12G
VVS055	TDF280/HM	25	UKP206	P206	UK206
VVS075	TDF315/GM	35	UKP208	P208	UK208
VVS100	TDF355/GM	40	UKP209	P209	UK209
VVS120	TDF400/GM	40	UKP209	P209	UK209
VVS150	TDF450/GM	45	UKP210	P210	UK210
VVS180	TDF500/HM	45	UKP210	P210	UK210
VVS230	TDF560/HM	45	UKP210	P210	UK210
VVS300	TDF560/GM	55	UKP212	P212	UK212
VVS400	TDF630/GM	60	UKP213	P213	UK213
VVS500	TDF710/GM	65	UKP215	P215	UK215
VVS650	TDF900/GM	70	UKP216	P216	UK216

After inspection and maintenance, check the fan rotation. If the direction of the fan rotation is not correct, the air will flow in the correct direction, but the fan performance will be significantly reduced.

8.1.14 MOTORS (AC)

Careful, regular maintenance and inspection of the engine's condition is essential to detect defects before serious damage occurs.

Before starting any work on the engine or other engine equipment, in particular, before removing guards to prevent direct contact with moving parts or those that may be live, the engine should be properly disconnected from the source of supply voltage. In addition, all auxiliary and auxiliary circuits should also be disconnected.



- ! The following safety rules should be followed:
- disconnect the power supply,
 - Apply protection against accidental restart,
 - check safe isolation from the power supply,
 - Use guards on adjacent live parts.
- ! All of the above-mentioned precautions should be maintained until all maintenance work is complete, and the engine is fully assembled and ready for startup.

For fan motor maintenance operations, check:

- whether the specified technical data are met (power consumption, winding temperature, bearings),
- whether there are no grease leaks,
- whether the engine is operating properly and whether noise from the engine and bearings is increasing,
- the correctness of the attachment of all mechanical and electrical connections,
- insulation resistance of the windings,
- whether the wires and insulation are in good condition and there is no discoloration.

Any changes or irregularities noted should be immediately corrected.

In addition, you should:

- carry out a bearing inspection as described for fan bearing inspection,
- check that the motor is properly secured and the mounting screws are tightened,
- check the state of dirt in the motor casing.

Excessive contamination impedes motor cooling, which can eventually lead to overheating of the motor winding and damage to the motor. The motor can be cleaned with a dry brush or blown with dry compressed air

8.1.15 MOTOR BEARINGS

The motors come standard with 62... series ball bearings equipped with a shield. When replacing or lubricating the bearing, it is necessary to disassemble the motor to the appropriate extent. When disassembling the motor, it is important to properly mark the components according to the order of disassembly. Use pullers or suitable equipment to disassemble centered parts.

Remove the bearing, clean the shaft journal, clean the bearing or replace it with a new one and replace it with new grease. Heat the bearing evenly to about $(+80) \text{ C}^{\circ} \div (+100)^{\circ} \text{ C}$ and then press it in. Strong impacts (e.g., with a hammer) should be avoided. All worn sealing elements should also be replaced.

All bearing voids should be filled with grease. To avoid excessive grease, do not lubricate the bearing casing and its shield.

For motors operating in rated conditions at ambient temperatures up to $(+40)^{\circ} \text{ C}$, the grease life is:

- Approximately 20,000 operating hours for speeds up to 1,500 rpm,

- Approximately 10,000 hours of operation for a rotational speed of 3,000 rpm When operating at 25°C, these times increase by about 100%.

Regardless of the number of operating hours, the grease should be replaced, every 3 years due to the aging effect. In this case, the bearings should be removed from the motor, cleaned of old grease and re-greased.

Type of grease used for engine bearings: ESSO/UNIREX N3.

The specified grease life and the time after which the bearing should be lubricated refer only to this grease. Do not mix different types of grease with each other!

LIST OF MOTOR BEARINGS - INDIRECT DRIVE FANS

MECHANICAL SIZE OF THE ENGINE	DRIVE-SIDE BEARING	BEARING AT THE REAR OF THE ENGINE
71	6002-2Z-C3	6002-2Z-C3
80	6004-2Z-C3	6004-2Z-C3
90	6205-2Z-C3	6004-2Z-C3
100	6206-2Z-C3	6205-2Z-C3
112	6206-2Z-C3	6205-2Z-C3
132	6208-2Z-C3	6208-2Z-C3
160	6209-2Z-C3	6209-2Z-C3
180	6210-Z-C3	6210-Z-C3
200	6212-Z-C3	6212-Z-C3
225	6213-Z-C3	6213-Z-C3
250	6215-Z-C3	6215-Z-C3

LIST OF MOTOR BEARINGS - INDIRECT DRIVE FANS

MECHANICAL SIZE OF THE ENGINE	DRIVE-SIDE BEARING	BEARING AT THE REAR OF THE ENGINE
71	6202-ZZ-C3	6202-ZZ-C3
80	6204ZZ-C3	6204ZZ-C3
90	6205ZZ-C3	6205ZZ-C3
100	6206ZZ-C3	6206ZZ-C3
112	6206ZZ-C3	6206ZZ-C3
132	6208-ZZ-C3	6208-ZZ-C3
160	6309-C3	6309-C3



! For EC motors, use bearing type: 6202 ZZ C3E

8.1.16 BELT TRANSMISSION

When servicing the fan unit, it is essential to check the tension of the V-belts and the parallelism of the pulley alignment. The factory-set belt tension should be checked after the first 50 hours of operation of the unit and subsequent adjustments should be carried out at 4-month intervals. A belt that is too loose can fall off the pulley or cause slippage and rapid belt wear, while too much belt tension can lead to heating and bearing damage and engine overload.

CHECK FOR PROPER V-BELT TENSION

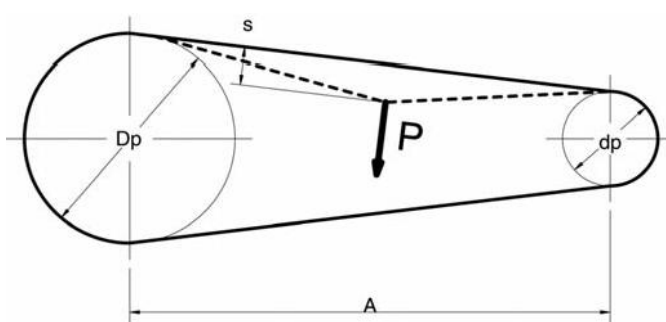

One should:

1. Measure the distance between the wheel axles (dimension A Figure 22 V-belt deflection),
2. Measure the force P needed to deflect the belt by $S=16$ mm for each running meter of distance between the axes, approximately halfway between the axes (Figure 22 V-belt deflection).
3. increase the tension of the belt, if the force is less, or decrease it, if it is greater than specified in this table. The amount of deflection force P^* depending on the type and diameter "dP" of the smaller wheel. The recommended belt tension is equal to $0.8 \times P_{max}$

! If the belts are not tensioned properly, tighten the belts by moving the motor with the tension screw located in the motor plate, and compare the tension values with the values in the table "TIGHTENING VOLUME P^* IN RELATION TO THE TYPE AND DIAMETER "DP" OF THE SMALLER WHEEL" depending on the type and diameter "dP" of the smaller wheel

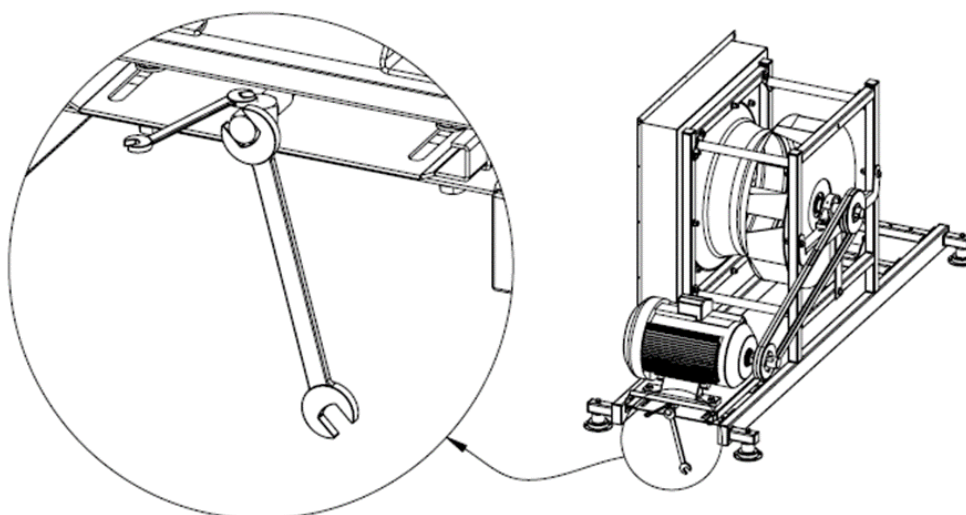

MAGNITUDE OF THE DEFLECTION FORCE P* DEPENDING ON THE TYPE AND DIAMETER "DP" OF THE SMALLER WHEEL						
	SPZ		SPA		SPB	
Diameter of the smaller wheel dP [mm].	67-95	100-140	100-140	>140	160-236	>236
Deflection force P(*) [N].	10-15	15-20	20-27	28-35	35-50	50-65
Deflection force P(*) [kg]	1.0-1.5	1.5-2.0	2.0-2.7	2.8-3.6	3.6-5.1	5.1-6.6

(*) - The force required to deflect the belt to the dimension s=16mm at the wheelbase A=1000mm

V-BELT DEFLECTION DEPENDING ON THE PULLEY CENTERLINE SPACING

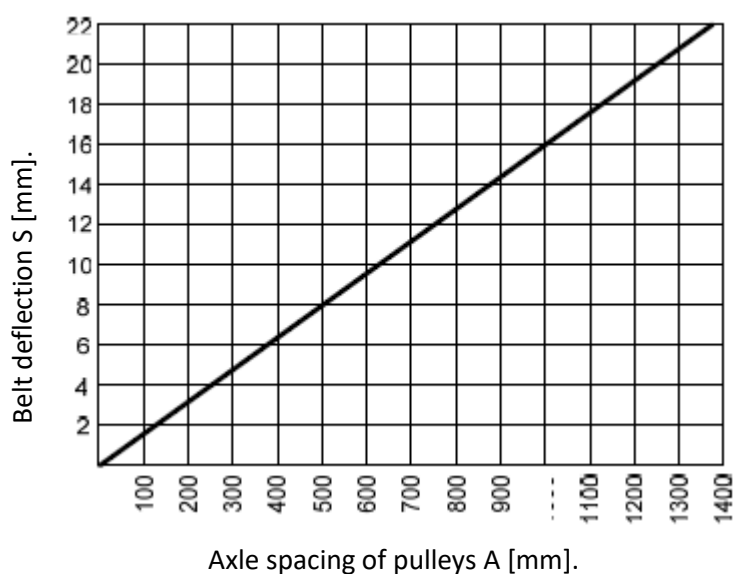

The V-belt should also be checked to make sure it is not rubbed, cracked, dried out or damaged in some other way. A damaged V-belt must be replaced. In the case of a multiple-belt drive, when at least one belt is worn, all the belts must be replaced, taking care that they are of the same length and type as the type of grooves in the pulley. If all the belts are not replaced, the new ones will carry more load, as they are slightly shorter than the old ones. When replacing the belts, loosen the engine plate tension bolt to such an extent that the belts can be removed and put on the wheels by hand without applying much force. Under no circumstances should the belts be forcibly tensioned with a screwdriver or any other tool. When replacing the belt, check the contact surfaces of the pulleys for wear. Tension the new belts so that the required deflection force P is closest to the value of P shown in the table "VOLUME OF DEFROSTING FORCE P* RELATING TO TYPE AND DIAMETER "DP" OF THE LOWER WHEEL". The amount of

deflection force P^* depending on the type and diameter "dP" of the smaller wheel. After installing the new belts, carry out a check of the alignment of the wheels, checking with a gauge that the pulleys are parallel and that their grooves lie in one plane. Once properly aligned, spin the drive without a load so that the belts settle into the grooves of the wheels. New belts should be re-tensioned after 50 hours of operation.

PULLEY ALIGNMENT

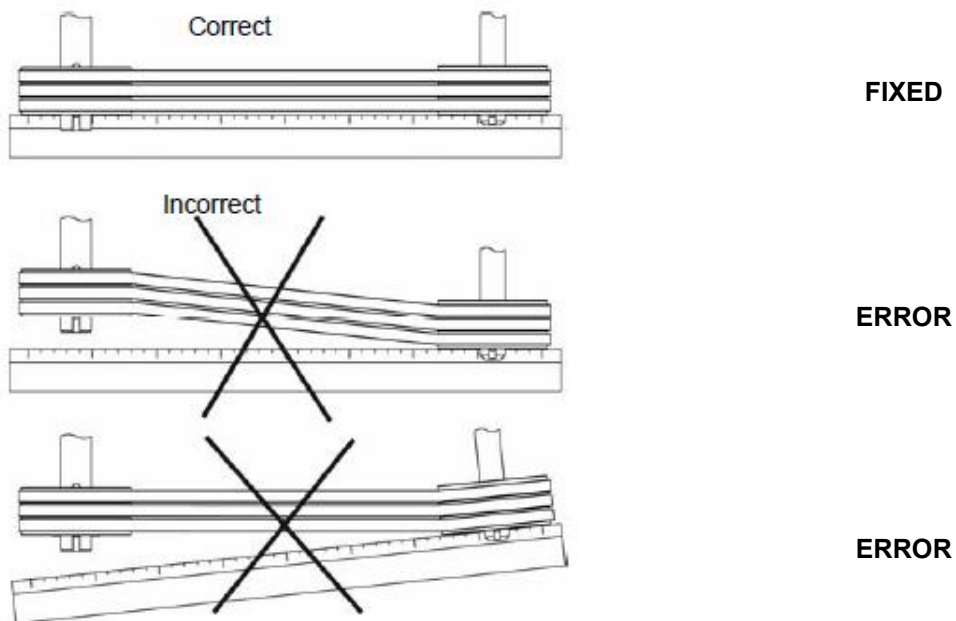

In order to correct the concentricity of the motor and fan shafts, the motor must be properly aligned on the tension plate. If it is found that the grooves of the wheels are not flush, one of the wheels (fan or motor) should be moved along the shaft to eliminate this shortcoming. This operation is made possible by equipping the wheel with a "Taper-Lock" type retractable bushing.

PULLEYS AND BUSHINGS

TAPER-LOCK PULLEY AND BUSHING

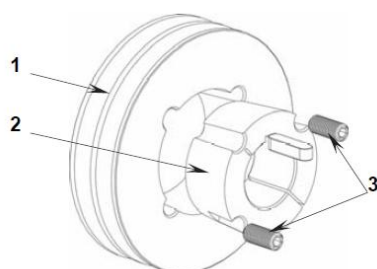

1. Pulley
2. "Taper-Lock" bushing
3. Hexagon socket screws

WHEEL WITH BUSHINGS NUMBERED FROM 1008 TO 3030

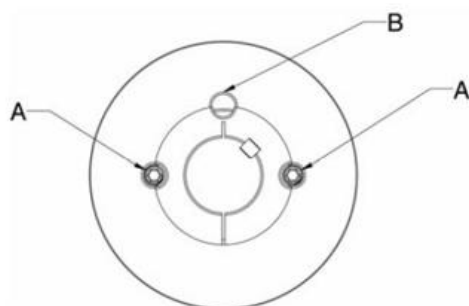

WHEEL WITH BUSHINGS NUMBER 3535 TO 5050

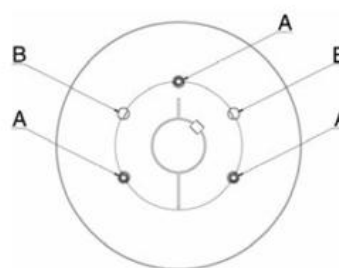

To move pulleys to adjust or replace the wheel with "Taper-Lock" bushings, follow these steps:

1. From the holes marked with the letter „A" (Fig. 27 or 28), screws with a hexagonal socket should be removed,
2. Screw the same screws into the hole marked „B" . Screw in the screws until the wheel and bushing on the shaft are loosened,
3. Move the bushing on the stub shaft of the motor or fan (if replacing, remove the bushing with the wheel and install a new set),
4. Re-screw the screws into the holes marked „A" until the first perceptible resistance,
5. Set the pulleys correctly,
6. Firmly tighten the mounting screws alternately to clamp the bushing with the wheel on the shaft journal

8.1.17 CONTROL MEASUREMENTS

After inspections and maintenance procedures, check and adjust the operating parameters of the device in accordance with the recommendations under "STARTING UP" and "ADJUSTMENT".

The fact that maintenance has been carried out and control measurements taken must be recorded in the Inspection and Maintenance Table.

8.2 CONSUMABLES AND SPARE PARTS

SKANUJ I KUP

ZESKANUJ KOD QR NA SWOJEJ CENTRALI LUB
ZNAJDŹ ZESTAW FILTRÓW PO NUMERZE URZĄDZENIA

KUP ZESTAW FILTRÓW
ONLINE
www.eshop.vtsgroup.com

! Replacement and consumable parts are available from the manufacturer's online store and from the network of authorized service centers at www.eshop.vtsgroup.com.

! Just enter the factory number

8.2.1 AIR FILTERS

PLATE AIR FILTER L =48 mm											
A x B	362 x 441	394 x 495	391 x 594	394 x 622	445 x 622	495 x 495	492 x 594	495 x 622	594 x 594	690 x 287	Coarse 80% (PG4)
VVS021	2										
VVS030		2									
VVS040						1	1				
VVS055				3							
VVS075	6										
VVS100		6									
VVS120			6								
VVS150					3			3			
VVS230							4		4		
VVS180						4		4			
VVS300				4					8		
VVS350		6							12		
VVS400		6							12		
VVS450		7							14		
VVS500		7							14		
VVS575							12		12		
VVS650							12		12		
VVS007										1	

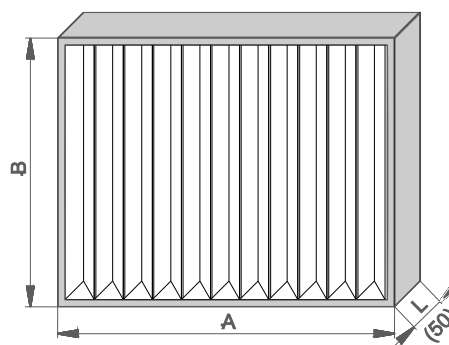

BAG AIR FILTERS L = 300 mm

A x B	428 x 287	428 x 428	490 x 490	592 x 592	592 x 287	490 x 592
VVS021	2					
VVS030		2				
VVS040			2			
VVS055				2		
VVS075	3	3				
VVS100	3		3			
VVS120				3	3	
VVS150			8			
VVS230						8
VVS180				8		
VVS300			15			
VVS350			6			12
VVS400			6			12
VVS450			7			14
VVS500			7			14
VVS575				18	6	
VVS650				18	6	
VVS007					1	

ISO ePM10 40%
ISO ePM 2.5 65% (EU7)

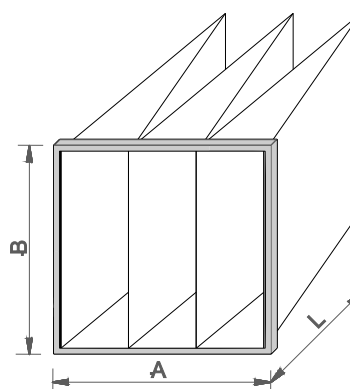
BAG AIR FILTERS L = 600 mm

A x B	428 x 287	428 x 428	490 x 490	592 x 592	592 x 287	490 x 592
VVS021	2					
VVS030		2				
VVS040			2			
VVS055				2		
VVS075	3	3				
VVS100	3		3			
VVS120				3	3	
VVS150			8			
VVS230						8
VVS180				8		
VVS300			15			
VVS350			6			12
VVS400			6			12
VVS450			7			14
VVS500			7			14
VVS575				18	6	
VVS650				18	6	

ISO ePM 2.5 65% (EU7)
ISO ePM 1 80% (EU9)

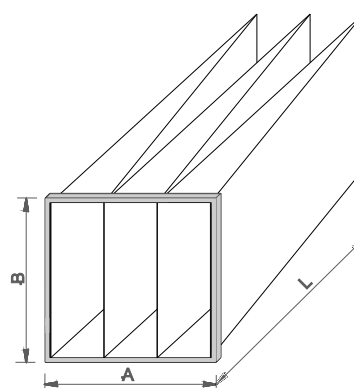

HEPA AIR FILTERS L = 292mm (H13, H14, H15)

Type	610 x610x292	610x305x292	305x305x292
A	610	610	305
B	610	610	305
L	292	292	292
VVS021		1	
VVS030		1	
VVS040		1	1
VVS055	2		
VVS075	2		
VVS100	2	1	
VVS120	2	1	
VVS150	3	3	
VVS230	3	4	1
VVS180	3	3	
VVS300	8		
VVS350	8	6	1
VVS400	8	6	1
VVS450	10	7	1
VVS500	10	7	1
VVS575	15	8	1
VVS650	15	8	1

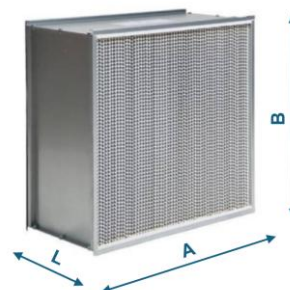

8.2.2 DX 5/16" EXCHANGERS

DX/DXH EXCHANGERS (5/16")													
5/16"	LL	LD	LH	HR	TR	D	E	F	G	ØD In	ØD out	Mass	Poj.
	[mm]										[kg]	[dm] ³	
VVS021c 2-1	710	873	300	321	110	41	91	75	13	5/8"	Ø28	4,15	1,02
VVS021c 3-1	710	873	300	321	140	45	120	75	13	5/8"	Ø28	5,24	1,46
VVS021c 4-1	710	873	300	321	170	49	131	75	13	5/8"	Ø28	6,81	1,89
VVS021c 6-1	710	873	300	321	235	56	194	75	26	Ø22	Ø28	9,48	2,75
VVS030c 2-1	710	873	425	448	110	41	91	75	45	5/8"	Ø28	5,18	1,45
VVS030c 3-1	710	873	425	448	140	45	120	75	45	5/8"	Ø28	6,73	2,06
VVS030c 4-1	710	873	425	448	170	49	131	75	65	5/8"	Ø28	8,75	2,67
VVS030c 6-1	710	873	425	448	235	56	194	75	52	Ø22	Ø28	12,33	3,9
VVS040c 2-1	930	1080	425	448	110	41	91	75	41	Ø22	Ø35	6,51	1,81
VVS040c 3-1	930	1080	425	448	140	45	120	75	45	5/8"	Ø28	8,51	2,6
VVS040c 4-1	930	1080	425	448	170	49	131	75	41	Ø22	Ø35	11,45	3,52
VVS040c 6-1	930	1080	425	448	235	56	194	75	54	Ø22	Ø35	16,07	5,11
VVS055c 2-1	1050	1251	575	587	110	41	91	120	84	Ø22	Ø28	9,16	2,71
VVS055c 3-1	1050	1251	575	587	140	45	120	120	98	Ø22	Ø35	12,21	3,92
VVS055c 4-1	1050	1251	575	587	170	49	131	120	66	Ø22	Ø35	16,25	5,29
VVS055c 6-1	1050	1251	575	587	235	56	194	120	55	Ø22	Ø42	23,16	7,93

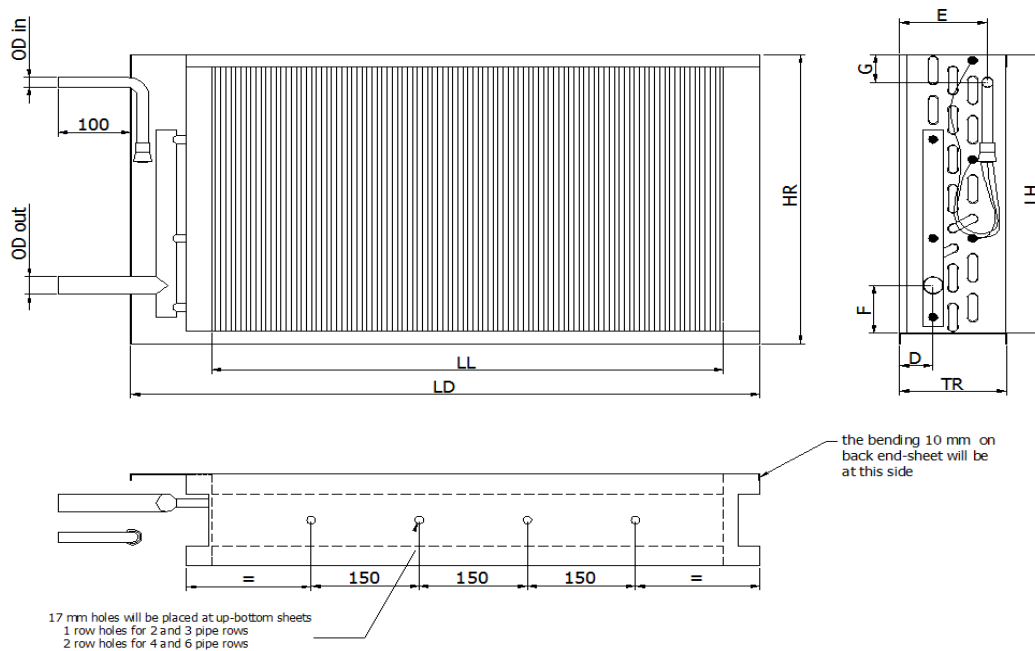

DX/DXH EXCHANGERS (5/16" - 2 SECTION)

5/16"	LL	LD	LH	HR	TR	D	E	F	G	K	ØD In	ØD out	Mass	Vol.
	[mm]												[kg]	[dm ³]
VVS030c 6	710	873	425	448	235	56	194	75	25	191	2x5/8"	2xØ28	14,96	4,0
VVS040c 4	930	1080	425	448	170	49	131	75	22	191	2x5/8"	2xØ28	13,82	3,4
VVS040c 6	930	1080	425	448	235	56	194	75	22	191	2x5/8"	2xØ28	19,06	5,0
VVS055c 3	1050	1251	575	587	140	45	100	120	25	222	2x5/8"	2xØ28	14,33	4,0
VVS055c 4	1050	1251	575	587	170	49	131	120	38	222	2x5/8"	2xØ28	18,7	5,1
VVS055c 6	1050	1251	575	587	235	56	194	120	19	222	2xØ22	2xØ35	26,71	7,7
VVS030c 6	710	873	425	448	235	56	194	75	25	191	2x5/8"	2xØ28	14,96	3,9
VVS040c 4	930	1080	425	448	170	49	75	22	191		2x5/8"	2xØ28	13,82	3,4
VVS040c 6	930	1080	425	448	235	56	75	22	191		2x5/8"	2xØ28	19,06	5,0
VVS055c 3	1050	1251	575	587	140	45	120	25	222		2x5/8"	2xØ28	14,33	4,0

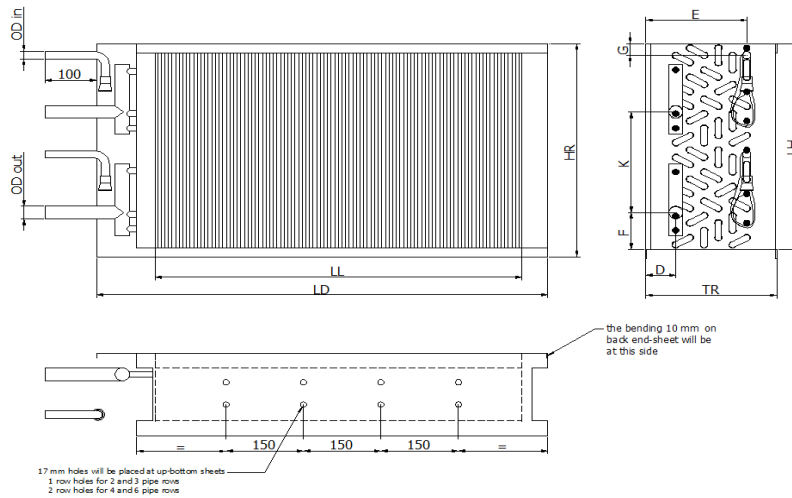

DX/DXH EXCHANGERS (5/16")

5/16"	LL	LD	LH	HR	TR	D	E	F	G	K	ØD In	ØD out	Mass	Vol.
	[mm]												[kg]	[dm ³]
VVS075c 2-1	1190	1392	700	702	110	41	91	120	63		5/8"	Ø28	12,1	3,7
VVS075c 3-1	1190	1392	700	702	140	45	120	120	116		Ø22	Ø28	16,3	5,3
VVS075c 3-2	1190	1392	700	702	140	45	100	120	76	318	2x5/8"	2xØ28	18,4	5,34
VVS075c 4-1	1190	1392	700	702	170	49	131	120	159		Ø22	Ø35	21,6	7,2
VVS075c 4-2	1190	1392	700	702	170	49	131	120	19	318	2x5/8"	2xØ28	24,1	7,0
VVS075c 6-1	1190	1392	700	702	235	56	194	120	97		Ø22	Ø42	31,5	10,8
VVS075c 6-2	1190	1392	700	702	235	56	194	120	58	318	2xØ22	2xØ28	34,6	10,5
VVS100c 2-1	1370	1572	800	806	110	41	91	120	87		Ø22	Ø28	15,9	4,8
VVS100c 2-2	1370	1572	800	806	110	41	91	120	57	381	2x5/8"	2xØ28	17,6	4,8
VVS100c 3-1	1370	1572	800	806	140	45	120	120	87		Ø22	Ø35	22,4	7,2
VVS100c 3-2	1370	1572	800	806	140	45	100	120	50	381	2x5/8"	2xØ28	23,6	6,9
VVS100c 4-1	1370	1572	800	806	170	49	131	120	113		Ø28	Ø42	30,5	9,6
VVS100c 4-2	1370	1572	800	806	170	49	131	120	49	381	2xØ22	2xØ28	31,7	9,3
VVS100c 6-2	1370	1572	800	806	235	56	194	120	42	381	2xØ22	2xØ35	43,7	13,7

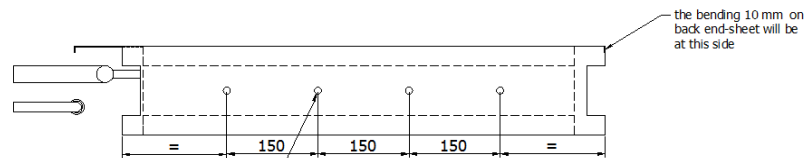
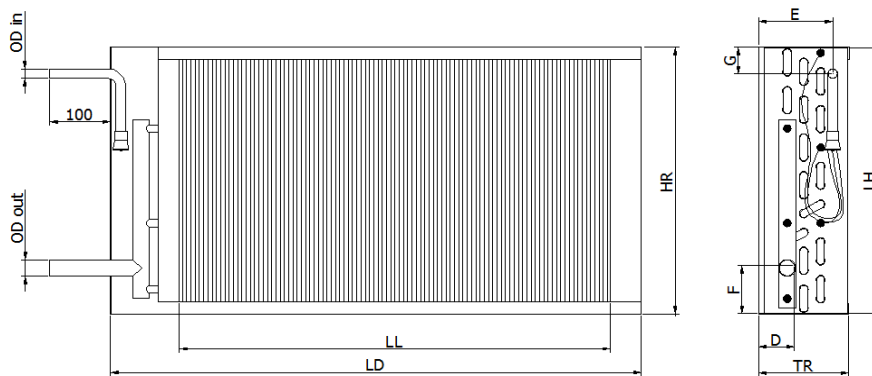

17 mm holes will be placed at up-bottom sheets
 1 row holes for 2 and 3 pipe rows
 2 row holes for 4 and 6 pipe rows

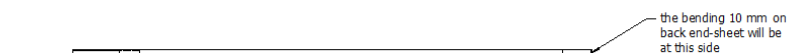
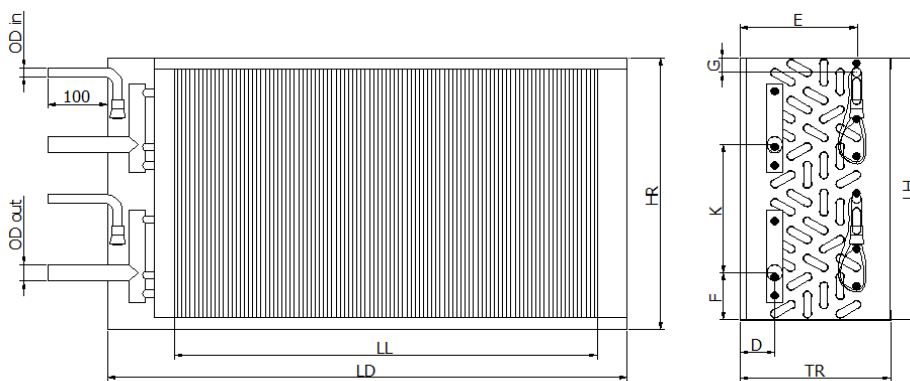

17 mm holes will be placed at up-bottom sheets
 1 row holes for 2 and 3 pipe rows
 2 row holes for 4 and 6 pipe rows

DX/DXH EXCHANGERS (5/16")

5/16"	LL	LD	LH	HR	TR	D	E	F	G	K	ØD In	ØD out	Mass	Vol.
	[mm]											[kg]	[dm ³]	
VVS120c 2-1	1600	1802	825	838	140	59	118	120	102		Ø22	Ø35	19,3	5,9
VVS120c 2-2	1600	1802	825	838	110	41	91	120	73	381	2x5/8"	2xØ28	21,9	5,9
VVS120c 3-1	1600	1802	825	838	170	45	120	120	125		Ø22	Ø42	27,1	8,8
VVS120c 3-2	1600	1802	825	838	140	45	100	120	35	381	2x5/8"	2xØ35	29,1	8,5
VVS120c 4-1	1600	1802	825	838	210	49	131	120	125		Ø22	Ø42	36,0	11,4
VVS120c 4-2	1600	1802	825	838	170	49	131	120	35	381	2xØ22	2xØ28	37,4	11,1
VVS120c 6-2	1600	1802	825	838	235	56	194	120	19	381	2xØ22	2xØ35	52,9	16,3
VVS150c 2-1	1780	1997	925	937	140	59	118	120	91		Ø22	Ø35	23,2	7,2
VVS150c 2-2	1780	1997	925	937	110	41	91	120	107	381	2x5/8"	2xØ28	25,0	7,0
VVS150c 3-1	1780	1997	925	937	170	63	143	120	78		Ø22	Ø42	33,6	10,8
VVS150c 3-2	1780	1997	925	937	140	45	100	120	49	381	2xØ22	2xØ35	35,5	10,5
VVS150c 4-1	1780	1997	925	937	210	66	164	120	123		Ø22	Ø54	43,4	14,1
VVS150c 4-2	1780	1997	925	937	170	49	131	120	69	381	2xØ22	2xØ35	45,0	13,7
VVS150c 6-2	1780	1997	925	937	235	56	194	120	59	381	2xØ22	2xØ42	65,6	20,6

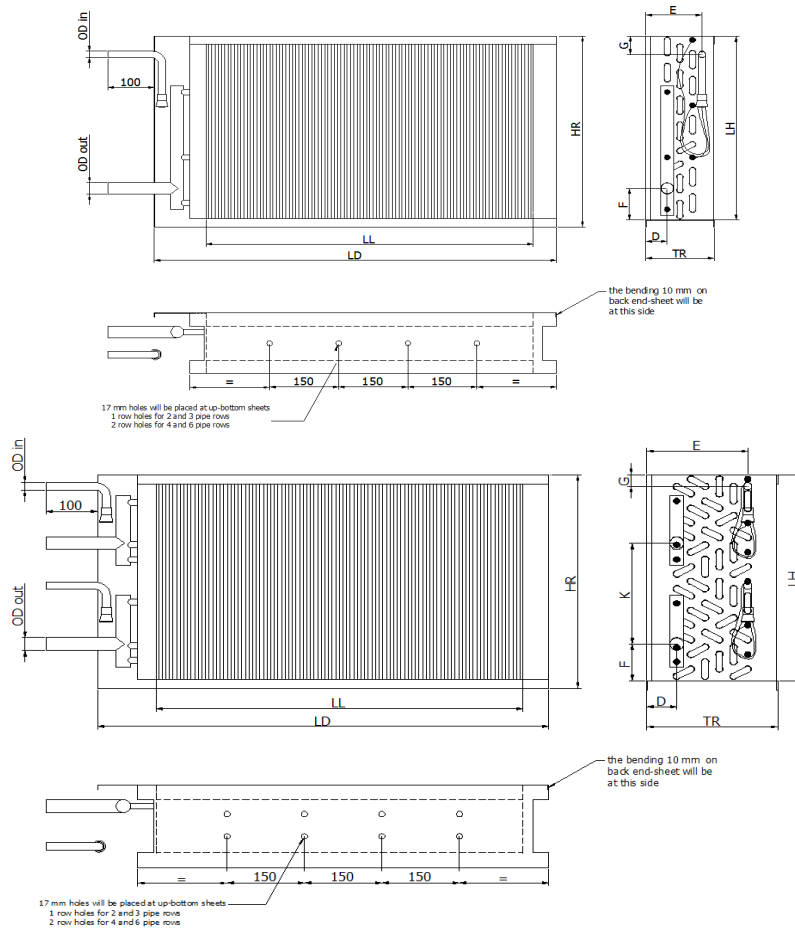

DX/DXH EXCHANGERS (5/16")

5/16"	LL	LD	LH	HR	TR	D	E	F	G	K	ØD In	ØD out	Mass	Vol.
	[mm]										[mm] // [inches].		[kg]	[dm ³]
VVS 180 2-1	1790	1997	1125	1137	140	59	118	120	152		Ø22	Ø42	28,5	9,3
VVS 180 2-2	1790	1997	1125	1137	140	59	118	120	125	508	2xØ22	2xØ35	30,6	8,8
VVS 180 3-1	1790	1997	1125	1137	170	63	143	127	159		Ø22	Ø54	41,1	13,3
VVS 180 3-2	1790	1997	1125	1137	140	45	100	120	131	508	2xØ22	2xØ28	42,6	12,8
VVS 180 4-2	1790	1997	1125	1137	170	49	131	120	109	508	2xØ22	2xØ42	55,0	17,2
VVS 180 6-2	1790	1997	1125	1137	235	56	194	120	131	508	2xØ22	2xØ42	39,3	25,2
VVS 230 2-2	2200	2405	1125	1137	140	59	118	120	124	508	2xØ22	2xØ35	42,4	11,1
VVS 230 3-2	2200	2405	1125	1137	140	45	100	120	131	508	2xØ22	2xØ35	61,1	15,9
VVS 230 4-2	2200	2405	1125	1137	205	66	150	120	88	508	2xØ22	2xØ54	67,1	21,1
VVS 230 6-2	2200	2405	1125	1137	280	74	211	120	95	508	2xØ28	2xØ54	94,6	31,4
VVS 300 2-2	2290	2497	1425	1441	140	59	118	120	192	667	2xØ22	2xØ42	53,8	14,5
VVS 300 3-2	2290	2497	1425	1441	280	45	100	120	192	667	2xØ22	2xØ42	74,2	20,9
VVS 300 4-2	2290	2497	1425	1441	280	66	225	120	96	667	2xØ22	2xØ54	89,8	28,5
VVS 300 6-2	2290	2497	1425	1441	280	74	211	120	95	667	2xØ28	2xØ54	124,8	41,3

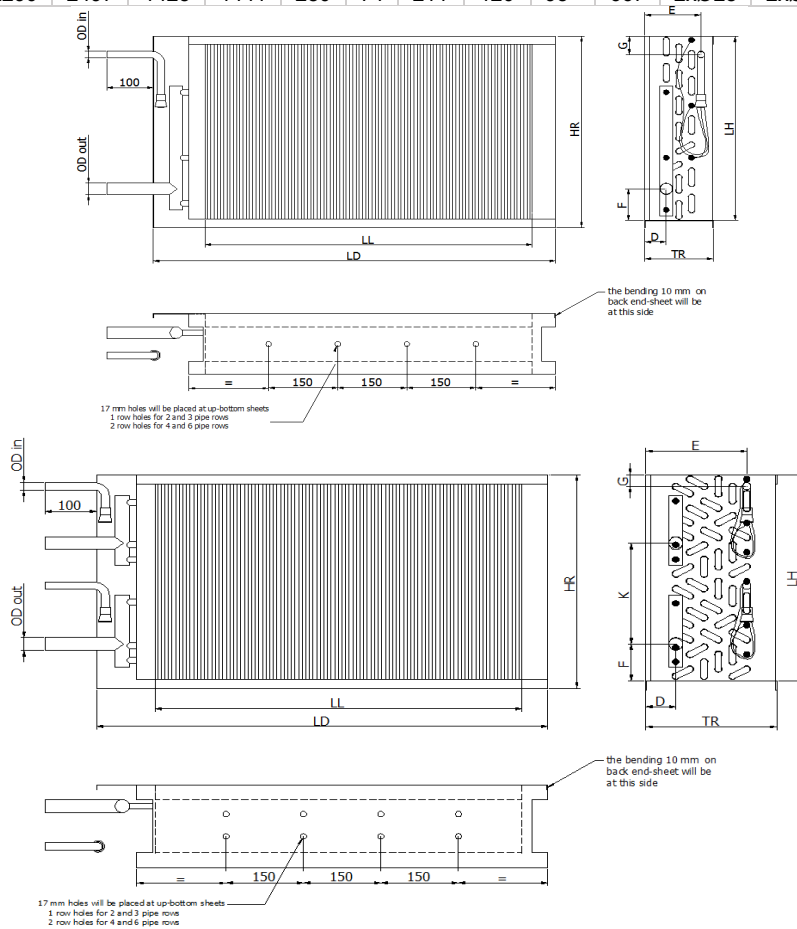

DX/DXH EXCHANGERS (5/16")

5/16"	Rows	LL	LD	LH	HR	TR	D	E	F	G	ØD in	ØD out	Mass	Vol.
[mm]														
													[kg]	[dm ³]
VVS400	2	2730	2997	825	828	285	59	175	120	100	2xØ22	Ø42	71,1	19
VVS400	3	2730	2997	825	828	285	45	185	120	100	2xØ28	Ø42	94,9	27,5
VVS500	2	3290	3497	825	828	285	59	175	120	100	2xØ28	Ø42	87,4	22,4
VVS500	3	3290	3497	825	828	285	63	222	120	100	2xØ28	Ø66	115,8	34,1

DX/DXH EXCHANGERS (5/16")

5/16"	Rows	LL	LD	LH	HR	TR	D	E	F	G1	G2	ØD in	ØD out	Mass	Vol.
[mm]															
														[kg]	[dm ³]
VVS400	4	2730	2997	825	828	285	66	225	120	100	420	4xØ28	Ø54	116,6	36,04
VVS400	6	2730	2997	825	828	285	74	211	120	100	420	4xØ35	Ø54	162,1	54,4
VVS500	4	3290	3497	825	828	285	66	225	120	100	420	4xØ35	Ø66	142,1	44,3
VVS500	6	3290	3497	825	828	285	74	211	120	100	420	4xØ35	Ø80	199,8	66,36

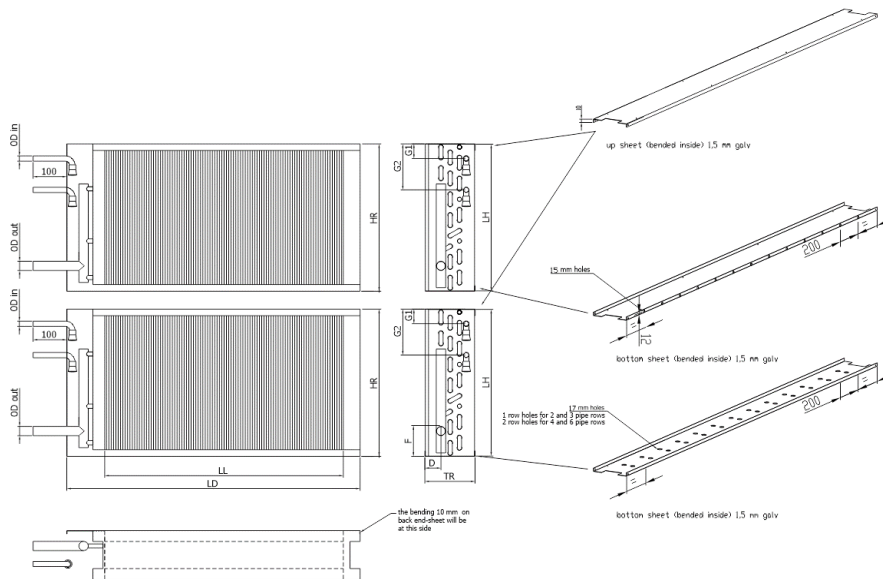

DX/DXH EXCHANGERS (5/16")

5/16"	Rows	LL	LD	LH	HR1	HR2	TR	D	E	F	G1	G2	ØD in	ØD out	Mass	Vol.
		[mm]														[kg]
VVS650	2	3400	3609	1050	1074	1054	285	59	233	120	100	420	4xØ22	Ø42	110,4	32,14
VVS650	3	3400	3609	1050	1074	1054	285	63	222	120	100	420	4xØ35	Ø66	146	46,02
VVS650	4	3400	3609	1050	1074	1054	285	66	225	120	100	420	4xØ35	Ø66	186,2	61,98

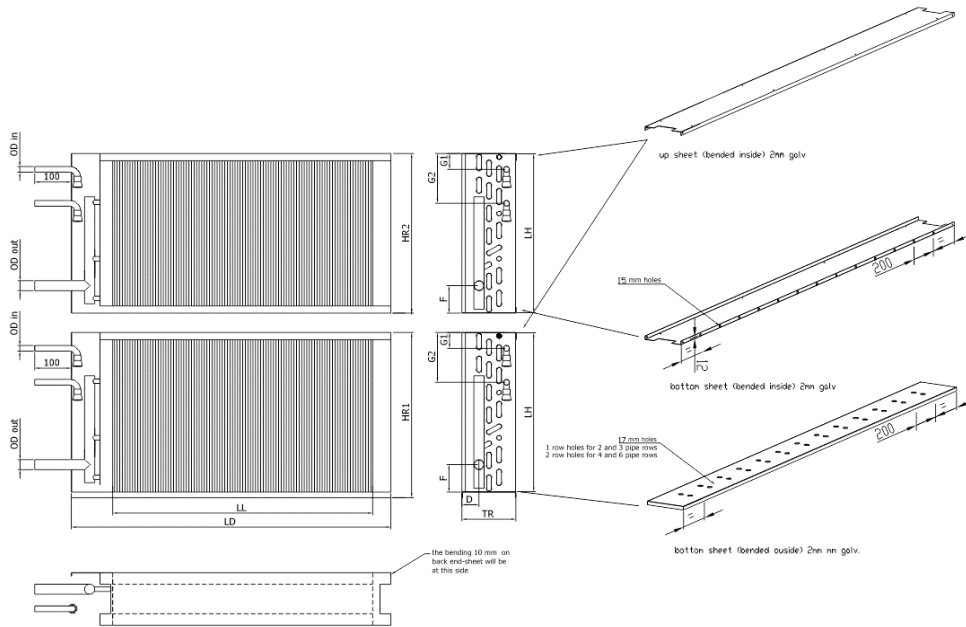

DX/DXH EXCHANGERS (5/16")

5/16"	Rows	LL	LD	LH	HR1	HR2	TR	D	E	F	G1	G2	G3	ØD in	ØD out	Mass	Vol.
		[mm]														[kg]	[dm ³]
VVS650	6	3400	3609	1050	1074	1054	285	74	211	120	100	420	640	6xØ42	2xØ80	258,8	89,74

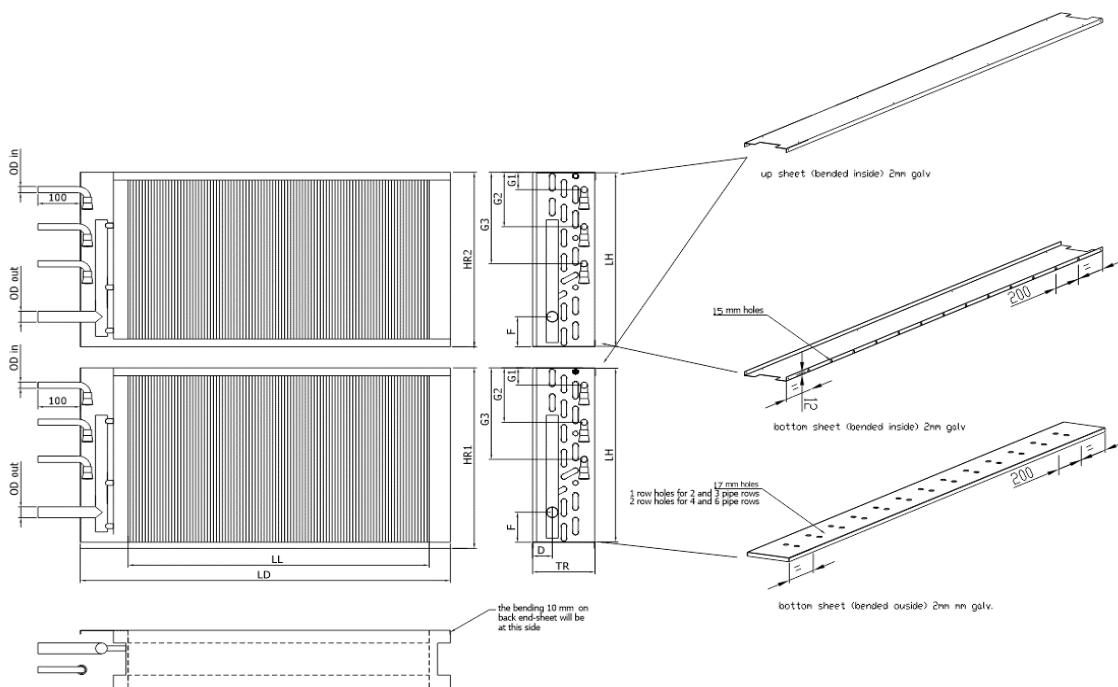

8.2.3 3/8" WCL (WATER) EXCHANGERS VVS021-VVS150

3/8" WATER EXCHANGERS															
VVS	Rows	LL	LD	LH	HR	C	HC	TR	D	d	De	Mass	Vol.	[mm]	
														[kg]	[dm ³]
VVS021c	WCL1	710	873	300	321	50	150	100	1"	1/4"	33,7	5,56	1		
VVS021c	WCL2	710	873	300	321	50	150	100	1"	1/4"	33,7	6,69	1,62		
VVS021c	WCL3	710	873	300	321	66	150	125	1"	1/4"	33,7	7,92	2,25		
VVS021c	WCL4	710	873	300	321	66	150	125	1"	1/4"	33,7	9,62	2,88		
VVS021c	WCL6	710	873	300	321	110	150	160	1"	1/4"	33,7	12,56	4,14		
VVS021c	WCL8	710	873	300	321	154	150	210	1"	1/4"	33,7	15,49	5,41		
VVS030c	WCL1	710	873	425	448	50	150	100	1"	1/4"	33,7	6,83	1,17		
VVS030c	WCL2	710	873	425	448	50	150	100	1"	1/4"	33,7	8,43	2,3		
VVS030c	WCL3	710	873	425	448	66	150	125	1"	1/4"	33,7	10,17	3,18		
VVS030c	WCL4	710	873	425	448	66	150	125	1"	1/4"	33,7	12,39	4,08		
VVS030c	WCL6	710	873	425	448	110	150	180	1 1/4"	1/4"	42,4	17,28	6,25		
VVS030c	WCL8	710	873	425	448	154	150	210	1 1/4"	1/4"	42,4	21,24	8,03		
VVS040c	WCL1	930	1080	425	448	50	150	100	1"	1/4"	33,7	7,81	2,02		
VVS040c	WCL2	930	1080	425	448	50	150	100	1"	1/4"	33,7	9,88	2,82		
VVS040c	WCL3	930	1080	425	448	66	150	125	1"	1/4"	33,7	12,13	3,98		
VVS040c	WCL4	930	1080	425	448	66	150	125	1"	1/4"	33,7	15	5,41		
VVS040c	WCL6	930	1080	425	448	110	150	180	1 1/4"	1/4"	42,4	21,06	7,82		
VVS040c	WCL8	930	1080	425	448	154	150	210	1 1/4"	1/4"	42,4	26,18	10,14		
VVS055c	WCL1	1050	1251	575	586	50	260	110	1 1/4"	1/4"	42,4	11,34	2,93		
VVS055c	WCL2	1050	1251	575	586	50	260	110	1 1/4"	1/4"	42,4	14,49	4,71		
VVS055c	WCL3	1050	1251	575	586	66	260	125	1 1/4"	1/4"	42,4	17,92	6,46		
VVS055c	WCL4	1050	1251	575	586	66	260	125	1 1/4"	1/4"	42,4	22,04	8,23		
VVS055c	WCL6	1050	1251	575	586	110	260	180	2"	1/4"	60,3	32,91	13,14		
VVS055c	WCL8	1050	1251	575	586	154	260	245	2"	1/4"	60,3	40,46	16,65		

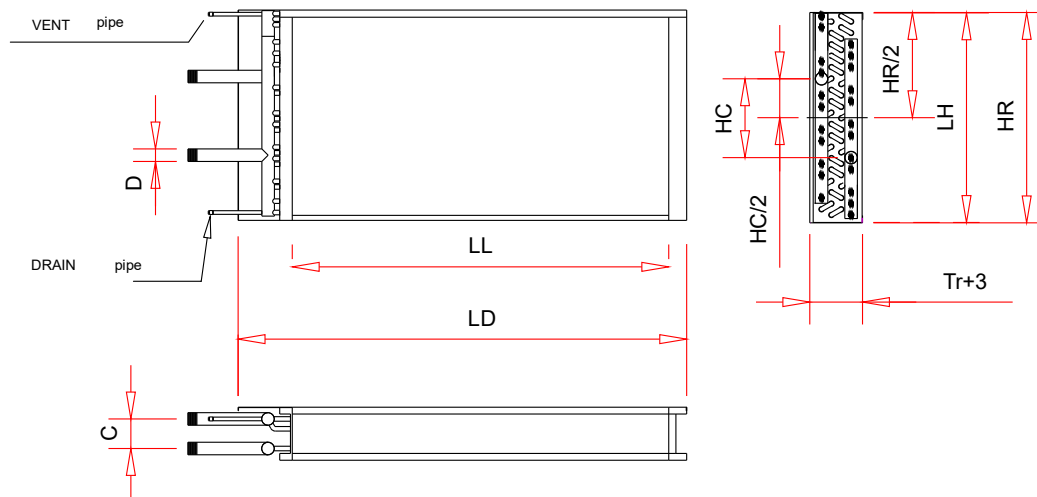

3/8" WATER EXCHANGERS

VVS	Rows	LL	LD	LH	HR	C	HC	TR	D	d	De	Mass	Vol.
		[mm]								[inch.]		[mm]	[kg]
VVS075c	WCL1	1190	1392	700	702	50	260	100	1 1/4"	1/4"	42,4	13,9	3,8
VVS075c	WCL2	1190	1392	700	702	50	260	100	1 1/4"	1/4"	42,4	18,2	6,3
VVS075c	WCL3	1190	1392	700	702	66	260	125	1 1/4"	1/4"	42,4	23,0	8,7
VVS075c	WCL4	1190	1392	700	702	66	260	125	1 1/4"	1/4"	42,4	28,5	11,1
VVS075c	WCL6	1190	1392	700	702	110	260	180	2"	1/4"	60,3	42,5	17,7
VVS075c	WCL8	1190	1392	700	702	154	260	245	2"	1/4"	60,3	52,8	22,5

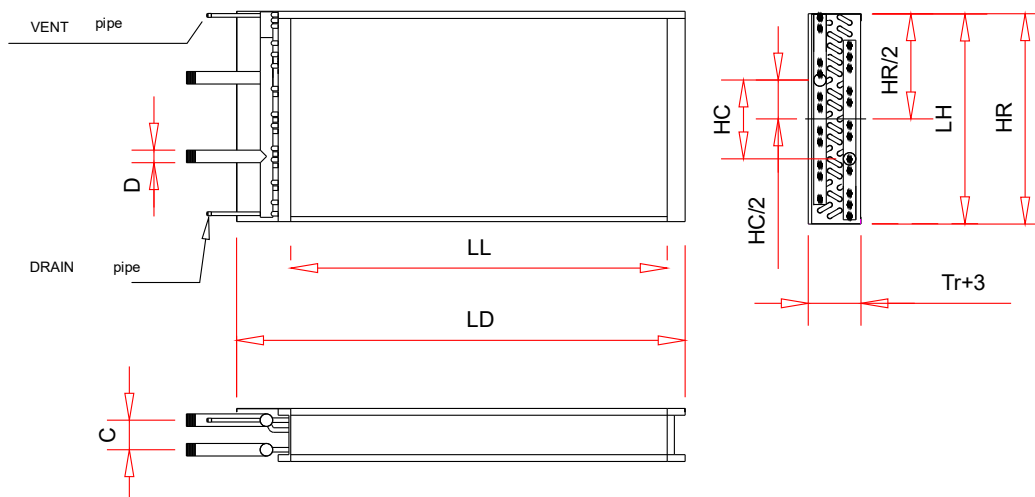

3/8" WATER EXCHANGERS

VVS	Rows	LL	LD	LH	HR	C	HC	TR	D	d	De	Mass	Vol.
									[mm]				
VVS100c	WCL1	1370	1572	800	806	50	260	100	1 1/4"	1/4"	25	5,0	24
VVS100c	WCL2	1370	1572	800	806	50	260	100	1 1/4"	1/4"	25	5,0	27
VVS100c	WCL3	1370	1572	800	806	66	260	160	2"	1/4"	25	5,0	24
VVS100c	WCL4	1370	1572	800	806	66	260	160	2"	1/4"	25	5,0	34
VVS100c	WCL6	1370	1572	800	806	110	260	180	2"	1/4"	25	5,0	24
VVS100c	WCL8	1370	1572	800	806	154	260	245	3"	1/4"	30	5,0	32
VVS120c	WCL1	1600	1802	825	838	50	260	100	1 1/4"	1/4"	25	12,0	24
VVS120c	WCL2	1600	1802	825	838	50	260	100	1 1/4"	1/4"	25	12,0	27
VVS120c	WCL3	1600	1802	825	838	66	260	160	2"	1/4"	25	12,0	24
VVS120c	WCL4	1600	1802	825	838	66	260	160	2"	1/4"	25	12,0	34
VVS120c	WCL6	1600	1802	825	838	110	260	210	3"	1/4"	30	12,0	24
VVS120c	WCL8	1600	1802	825	838	154	260	245	3"	1/4"	30	12,0	32
VVS150c	WCL1	1790	1997	925	937	50	260	100	1 1/4"	1/4"	25	11,0	24
VVS150c	WCL2	1790	1997	925	937	50	260	100	1 1/4"	1/4"	25	11,0	27
VVS150c	WCL3	1790	1997	925	937	66	260	160	2"	1/4"	25	11,0	24
VVS150c	WCL4	1790	1997	925	937	66	260	160	2"	1/4"	25	11,0	34
VVS150c	WCL6	1790	1997	925	937	110	260	210	3"	1/4"	30	11,0	24
VVS150c	WCL8	1790	1997	925	937	154	260	245	3"	1/4"	30	11,0	32

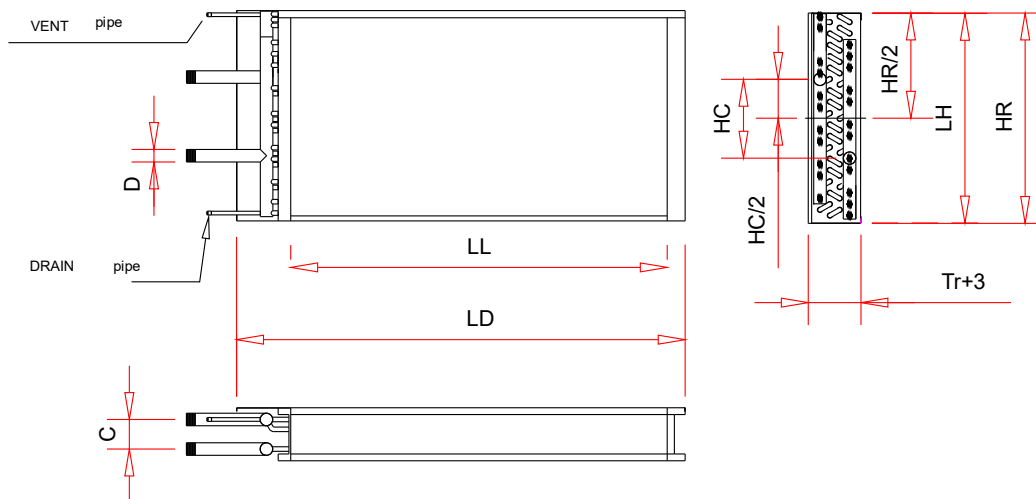

8.2.4 1/2" WCL (WATER) EXCHANGERS VVS180-VVS650

WATER EXCHANGERS WCL 1/2"													
VVS	Rows	LL	LD	LH	HR	C	HC	TR	D	d	De	Mass	Vol.
[-]	[-]	[mm]								[inch]	[mm]	[kg]	[dm ³]
VVS180	WCL1	1790	1997	1112	1137	82,5	260	180	2"	1/4"	60,3	48,63	12,97
VVS180	WCL2	1790	1997	1112	1137	82,5	260	215	2"	1/4"	60,3	66,66	15,62
VVS180	WCL3	1790	1997	1112	1137	99	260	215	3"	1/4"	88,9	89,50	35,64
VVS180	WCL4	1790	1997	1112	1137	99	260	215	3"	1/4"	88,9	103,51	31,24
VVS180	WCL6	1790	1997	1112	1137	138	260	250	3"	1/4"	88,9	134,40	46,86
VVS180	WCL8	1790	1997	1112	1137	137,5	260	285	3"	1/4"	88,9	167,77	62,47
VVS180	WCL12	1790	1997	1112	1137	301,7	260	395	3"	1/4"	88,9	229,6	106,68
VVS180	WCL16	1790	1997	1112	1137	412,5	260	504	3"	1/4"	88,9	277,8	138,29
VVS230	WCL1	2200	2405	1112	1137	99	260	215	2"	1/4"	60,3	58,36	14,73
VVS230	WCL2	2200	2405	1112	1137	99	260	215	3"	1/4"	88,9	84,07	19,2
VVS230	WCL3	2200	2405	1112	1137	99	260	215	3"	1/4"	88,9	101,37	41,15
VVS230	WCL4	2200	2405	1112	1137	99	260	215	3"	1/4"	88,9	118,51	38,39
VVS230	WCL6	2200	2405	1112	1137	137,5	260	250	3"	1/4"	88,9	155,99	57,59
VVS230	WCL8	2200	2405	1112	1137	137,5	260	285	3"	1/4"	88,9	195,96	76,78
VVS230	WCL12	2200	2405	1112	1137	301,7	260	395	3"	1/4"	88,9	271,4	127,87
VVS230	WCL16	2200	2405	1112	1137	412,5	260	504	3"	1/4"	88,9	331	166,52
VVS300	WCL1	2290	2497	1397	1411	99	260	215	3"	1/4"	88,9	82,89	19,44
VVS300	WCL2	2290	2497	1397	1411	99	260	215	3"	1/4"	88,9	105,68	25,69
VVS300	WCL3	2290	2497	1397	1411	99	260	215	3"	1/4"	88,9	128,80	42,22
VVS300	WCL4	2290	2497	1397	1411	99	260	215	3"	1/4"	88,9	151,71	51,38
VVS300	WCL6	2290	2497	1397	1411	137,5	260	250	3"	1/4"	88,9	201,20	77,07
VVS300	WCL8	2290	2497	1397	1411	137,5	260	285	3"	1/4"	88,9	253,17	102,76
VVS300	WCL12	2290	2497	1429	1441	301,7	260	395	3"	1/4"	88,9	351,4	170,37
VVS300	WCL16	2290	2497	1429	1441	412,5	260	504	3"	1/4"	88,9	433,1	222,06

- * without refrigerant (water or glycol solution).

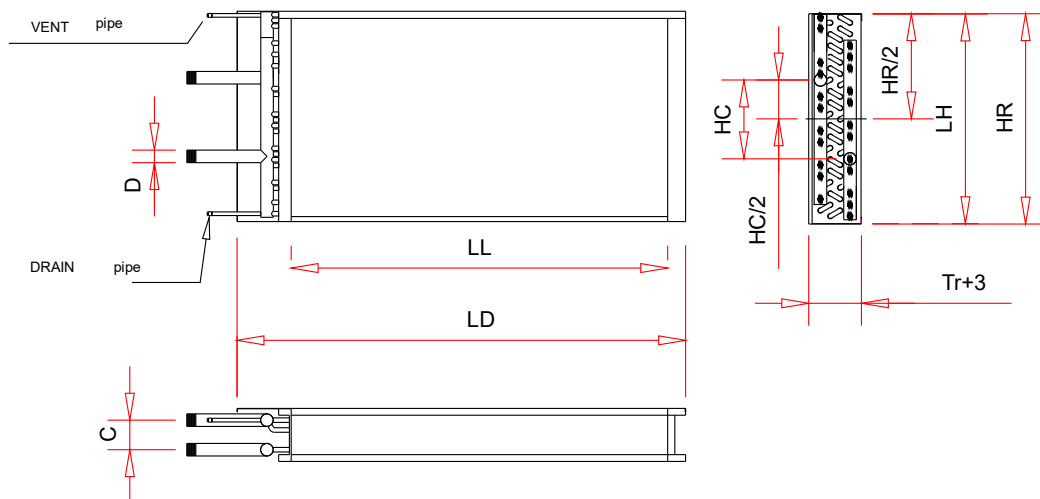

WATER EXCHANGERS WCL 1/2"

VVS	Rows	LL	LD	LH	HR	C	HC	TR	D	d	De	Mass	Vol.
[-]	[-]	[mm]							[inch]	[inch]	[mm]	[kg]	[dm ³]
VVS400	WCL1	2730	2997	794	803	99	260	215	3"	1/4"	88,9	126	17
VVS400	WCL2	2730	2997	794	803	99	260	215	3"	1/4"	88,9	156	34
VVS400	WCL3	2730	2997	794	803	99	260	215	3"	1/4"	88,9	187	69
VVS400	WCL4	2730	2997	794	803	99	260	215	3"	1/4"	88,9	218	87
VVS400	WCL6	2730	2997	794	803	138	260	250	3"	1/4"	88,9	287	104
VVS400	WCL8	2730	2997	794	803	138	260	285	3"	1/4"	88,9	356	138
VVS400	WCL12	2730	2997	794	827	301,7	260	395	3"	1/4"	88,9	488	226
VVS400	WCL16	2730	2997	794	827	412,5	260	504	3"	1/4"	88,9	590	295
VVS500	WCL1	3290	3497	794	803	99	260	215	3"	1/4"	88,9	161	38
VVS500	WCL2	3290	3497	794	803	99	260	215	3"	1/4"	88,9	199	42
VVS500	WCL3	3290	3497	794	803	99	260	215	3"	1/4"	88,9	237	71
VVS500	WCL4	3290	3497	794	803	99	260	215	3"	1/4"	88,9	275	85
VVS500	WCL6	3290	3497	794	803	138	260	250	3"	1/4"	88,9	361	127
VVS500	WCL8	3290	3497	794	803	138	260	285	3"	1/4"	88,9	447	170
VVS500	WCL12	3290	3497	794	828	301,7	260	395	3"	1/4"	88,9	604	275
VVS500	WCL16	3290	3497	794	828	412,5	260	504	3"	1/4"	88,9	720	358
VVS650	WCL1	3400	3609	1048	1059	99	260	215	3"	1/4"	88,9	194	51
VVS650	WCL2	3400	3609	1048	1059	99	260	215	3"	1/4"	88,9	245	56
VVS650	WCL3	3400	3609	1048	1059	99	260	215	3"	1/4"	88,9	295	95
VVS650	WCL4	3400	3609	1048	1059	99	260	215	3"	1/4"	88,9	345	113
VVS650	WCL6	3400	3609	1048	1059	138	260	250	3"	1/4"	88,9	458	170
VVS650	WCL8	3400	3609	1048	1059	138	260	285	3"	1/4"	88,9	570	227
VVS650	WCL12	3400	3609	1048	1064	301,7	260	395	3"	1/4"	88,9	781	363
VVS650	WCL16	3400	3609	1048	1064	412,5	260	504	3"	1/4"	88,9	948	476

- * without refrigerant (water or glycol solution).

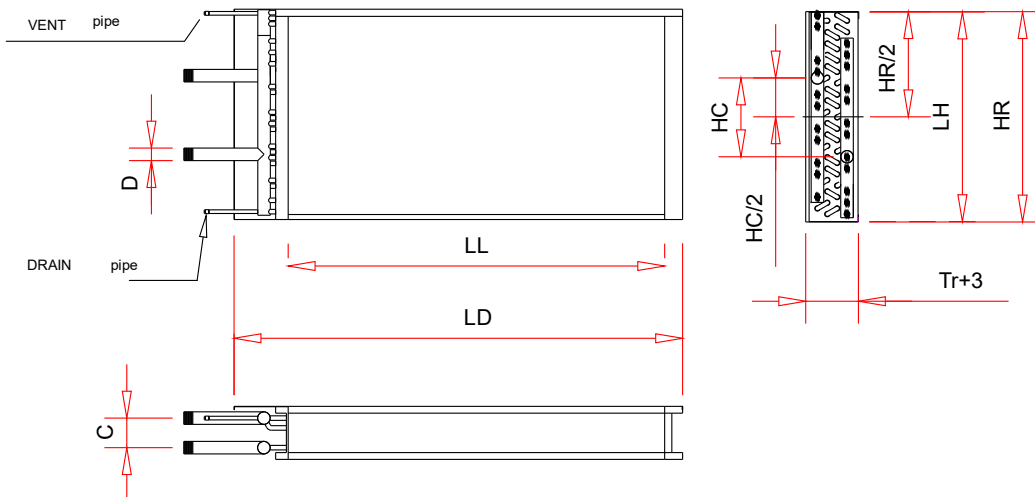

9 ADDITIONAL INFORMATION

9.1 TECHNICAL INFORMATION TO REGULATION (EU) 327/2011, IMPLEMENTING DIRECTIVE 2009/125/EC

SR-FS FANS							
Fan Set Model	#2	#5	#9-1	#9-2	#9-3	#10	#11
	[%]	[%]	[-]	[kW]	[m³/h].	[Pa]	[rpm]
SR-FS-P-225-0.3	65,40	73,30	SR-FS-P-225-0.3	0,43	1 288	704	3 600
SR-FS-P-225-0.7	62,00	68,10	SR-FS-P-225-0.7	0,85	1 642	1 065	4 500
SR-FS-P-250-0.3	66,20	73,30	SR-FS-P-250-0.3	0,49	1 676	633	3 000
SR-FS-P-250-0.7	67,40	72,40	SR-FS-P-250-0.7	0,98	2 060	1 058	3 800
SR-FS-P-315-0.3	65,40	72,70	SR-FS-P-315-0.3	0,49	2 256	461	2 060
SR-FS-P-315-0.7	66,20	72,00	SR-FS-P-315-0.7	0,75	2 411	674	2 400
SR-FS-P-315-1.5	69,70	73,00	SR-FS-P-315-1.5	1,77	3 560	1 164	3 250
SR-FS-P-315-2.5	67,80	70,40	SR-FS-P-315-2.5	2,44	3 964	1 419	3 600
SR-FS-A-225-0.3	62,70	71,10	SR-FS-A-225-0.3	0,41	1 238	674	3 600
SR-FS-A-225-0.7	59,70	66,20	SR-FS-A-225-0.7	0,83	1 527	1 069	4 500
SR-FS-A-250-0.3	62,40	70,00	SR-FS-A-250-0.3	0,48	1 456	672	3 000
SR-FS-A-250-0.7	65,20	70,60	SR-FS-A-250-0.7	0,93	2 111	950	3 800
SR-FS-A-315-0.3	62,30	70,20	SR-FS-A-315-0.3	0,46	2 119	437	2 060
SR-FS-A-315-0.7	64,40	70,60	SR-FS-A-315-0.7	0,71	2 296	648	2 400
SR-FS-A-315-1.5	67,60	71,30	SR-FS-A-315-1.5	1,69	3 428	1 118	3 250
SR-FS-A-315-2.5	67,10	69,90	SR-FS-A-315-2.5	2,33	3 902	1 363	3 600
SR-FS-A-355-1.6	70,00	73,60	SR-FS-A-355-1.6	1,65	4 017	967	2 650
SR-FS-A-355-2.5	69,90	72,20	SR-FS-A-355-2.5	2,50	4 513	1 316	3 000
SR-FS-A-355-3.7	66,90	68,40	SR-FS-A-355-3.7	3,57	5 199	1 573	3 400
SR-FS-A-400-1.6	70,70	73,70	SR-FS-A-400-1.6	1,89	4 876	920	2 250
SR-FS-A-400-2.5	68,40	71,00	SR-FS-A-400-2.5	2,41	6 366	879	2 000
SR-FS-A-400-3.7	66,70	67,90	SR-FS-A-400-3.7	3,83	5 836	1 499	2 850
SR-FS-A-400-5.4	66,70	66,70	SR-FS-A-400-5.4	5,65	6 802	1 916	3 250
SR-FS-A-450-1.6	70,20	73,60	SR-FS-A-450-1.6	1,75	5 176	798	1 800
SR-FS-A-450-2.5	68,10	71,00	SR-FS-A-450-2.5	2,24	5 068	1 021	2 400
SR-FS-A-450-3.7	67,70	69,20	SR-FS-A-450-3.7	3,57	7 086	1 170	2 300
SR-FS-A-450-5.4	66,80	67,10	SR-FS-A-450-5.4	5,29	8 021	1 526	2 600
SR-FS-A-500-3.7	69,80	71,20	SR-FS-A-500-3.7	3,59	8 577	1 001	1 900
SR-FS-A-500-5.4	70,10	70,50	SR-FS-A-500-5.4	5,06	9 562	1 284	2 130
SR-FS-A-560-3.7	69,00	70,40	SR-FS-A-560-3.7	3,58	9 486	893	1 600
SR-FS-A-560-5.4	69,00	69,00	SR-FS-A-560-5.4	5,52	11 192	1 176	1 830
PARAMETER ACCORDING TO (EU) 327/2011	VALUE						
#3	A						
#4	Static						
#6	Year of manufacture printed on the product nameplate.						
#7	Swiss Rotors sp. z o.o. , 586-001-73-79 , Rumska 18, 81-198, Dębogórze, Poland						
#8	YES						
#12	Disposal shall be carried out in an appropriate and environmentally friendly manner in accordance with the laws of the country. "Materials shall be sorted and segregated in an environmentally friendly manner." If necessary, they should be returned to a specialized facility.						
#13	Information provided in the relevant sections of the dedicated manual, especially on maintenance (www. https://swissrotors.com)						
#14	N/A						

TECHNICAL INFORMATION FOR REGULATION (EU) No 327/2011 IMPLEMENTING DIRECTIVE 2009/125/EC									
Model:	22/0.55/2 IE3	22/0.75/2 IE3	25/0.75/2 IE3	25/1.5/2 IE3	31/1.1/2 IE3	31/1.5/2 IE3	31/2,2/2 IE3	35/1.5/4 IE3	35/2.2/2 IE3
1	64,10%	64,20%	63,30%	66,40%	64,10%	64,20%	65,20%	66,70%	64,20%
2	A								
3	Static								
4	62								
5	VSD - yes. Requires installation of speed control for the fan								
6	Specified on the fan nameplate								
7	VTS Sp. z o.o. , 472A Al. Grunwaldzka, 80-309 Gdańsk, Poland								
8	22/0.55/2 IE3	22/0.75/2 IE3	25/0.75/2 IE3	25/1.5/2 IE3	31/1.1/2 IE3	31/1.5/2 IE3	31/2,2/2 IE3	35/1.5/4 IE3	35/2.2/2 IE3
9	-	0,223	0,402	0,385		1,219	1,225	0,272	2,227
	kW	kW	kW	kW	kW	kW	kW	kW	kW
	1001	1010	1419	1400	854	2900	2990	2000	4150
	m3/h	m3/h	m3/h	m3/h	m3/h	m3/h	m3/h	m3/h	m3/h
	424	451	580	590	854	899	890	290	1167
10	Bye	Bye	Bye	Bye	Bye	Bye	Bye	Bye	Bye
10	2790	285	2855	2860	2854	2860	2860	1420	2880
	rpm	rpm	rpm	rpm	rpm	rpm	rpm	rpm	rpm
11	1								
12	Disassembly of the device should be carried out and/or supervised by appropriately qualified personnel with the appropriate level of expertise. Contact a certified waste disposal organization in your region. Explain what is to follow in terms of the quality of the disassembly of the device and the protection of the components. Disassemble the unit using general procedures commonly used in mechanical engineering.								
	<p>WARNING: The fan assembly consists of heavy parts. These parts may fall during disassembly, which may cause death, serious personal injury or property damage. Be familiar with safety rules</p> <ol style="list-style-type: none"> 1. disconnect the supply voltage including all related circuits. 2. prevent accidental re-engagement. 3 Ensure that the equipment is de-energized. 4. protect or insulate components that are powered and in the vicinity. To restore power to the system, apply measures in reverse order. 								
	<p>Components: The equipment consists mostly of various proportions of steel, copper, aluminum and plastics (rotor made of SAN - styrene, acrylonitrile, structural material with the addition of 20% glass fiber). Components should be sorted when recycled by material: iron and steel, aluminum, copper, non-ferrous metals such as winding (winding insulation will be burned when recycling copper), insulating materials, electrical wiring, electronic waste, plastic components (fan rotor, winding covers, etc.). The same applies to fabrics and cleaning substances that were used during the disassembly of components. Separation of components should be done according to local regulations or by a specialized recycling firm.</p>								
13	The long period of trouble-free operation is dependent on maintaining the product/device/fan within the range of operating parameters specified by the selection program and use in accordance with the intended use specified in the technical and operating documentation supplied with the device. For proper operation and operation of the device, you should also familiarize yourself with the information contained in the technical documentation in the chapters: installation, commissioning, operation and maintenance.								
14	No additional elements								

TECHNICAL INFORMATION FOR REGULATION (EU) No 327/2011 IMPLEMENTING DIRECTIVE 2009/125/EC									
Model:	35/3/2 IE3	40/1.5/4 IE3	40/2.2/4 IE3	40/3/4 IE3	45/2.2/4 IE3	45/4/4 IE3	45/5.5/4 IE3	50/4/4 IE3	50/5.5/4 IE3
1	65,00%	68,30%	67,80%	64,90%	66,40%	67,90%	68,50%	67,00%	67,60%
2	A								
3	Static								
4	62								
5	VSD - yes. Requires installation of speed control for the fan								
6	Specified on the fan nameplate								
7	VTS Sp. z o.o. , 472A Al. Grunwaldzka, 80-309 Gdańsk, Poland								
8	35/3/2 IE3	40/1.5/4 IE3	40/2.2/4 IE3	40/3/4 IE3	45/2.2/4 IE3	45/4/4 IE3	45/5.5/4 IE3	50/4/4 IE3	50/5.5/4 IE3
9	2,255	0,262	0,441	3,03	0,818	0,835	0,851	1,482	1,513
	kW	kW	kW	kW	kW	kW	kW	kW	kW
	4300	1910	2500	5600	4000	4100	4000	5900	5775
	m3/h	m3/h	m3/h	m3/h	m3/h	m3/h	m3/h	m3/h	m3/h
	1156	300	388	1200	448	456	481	564	594
10	Bye	Bye	Bye	Bye	Bye	Bye	Bye	Bye	Bye
10	2835	1420	1420	2673	1420	1440	1455	1440	1455
10	rpm	rpm	rpm	rpm	rpm	rpm	rpm	rpm	rpm
11	1								
12	<p>Disassembly of the device should be carried out and/or supervised by properly qualified personnel with the appropriate level of expertise. Contact a certified waste disposal organization in your region. Explain what is to follow in terms of the quality of the disassembly of the device and the protection of the components. Disassemble the unit using general procedures commonly used in mechanical engineering.</p> <p>WARNING: The fan assembly consists of heavy parts. These parts may fall during disassembly, which may cause death, serious personal injury or property damage. Be familiar with safety rules</p> <ol style="list-style-type: none"> 1. disconnect the supply voltage including all related circuits. 2. prevent accidental re-engagement. 3. make sure the equipment is de-energized. 4. protect or insulate components that are powered and are in the vicinity. <p>To restore power to the system, apply measures in reverse order.</p> <p>Components: The equipment consists mostly of various proportions of steel, copper, aluminum and plastics (rotor made of SAN - styrene, acrylonitrile, structural material with the addition of 20% glass fiber). Components should be sorted when recycled by material: iron and steel, aluminum, copper, non-ferrous metals such as winding (winding insulation will be burned when recycling copper), insulation materials, electrical wiring, electronic waste, plastic components (fan rotor, winding covers, etc.). The same applies to fabrics and cleaning substances that were used during the disassembly of components. Separation of components should be done according to local regulations or by a specialized recycling firm.</p>								
13	The long period of trouble-free operation is dependent on maintaining the product/device/fan within the range of operating parameters specified by the selection program and use in accordance with the intended use specified in the technical and operating documentation supplied with the device. For proper operation and operation of the device, you should also familiarize yourself with the information contained in the technical documentation in the chapters: installation, commissioning, operation and maintenance.								
14	No additional elements								

WGM FANS							
Fan Set Model	#2	#5	#9-1	#9-2	#9-3	#10	#11
	[%]	[%]	[-]	[kW]	[m³/h]	[Pa]	[rpm]
WGM250-0.75 EC102/50E3G01- B250/85A2-11-Z	58,3	70,1	WGM250-0.75 EC102/50E3G01-B250/85A2- 11-Z	0,75	1800	800	3700
WGM315-1.2 EC137/40D3G01- B315/100A2-11-Z	68,9	78,6	WGM315-1.2 EC137/40D3G01- B315/100A2-11-Z	1,20	3079	900	3000
WGM315-3.3 EC137/80D3G84- B315/100A2-11-Z	62,3	67,4	WGM315-3.3 EC137/80D3G84- B315/100A2-11-Z	3,30	4100	1700	4000
WGM400-2.7 EC137/80D3G81- B400/140A2-11-Z	60,7	66,7	WGM400-2.7 EC137/80D3G81- B400/140A2-11-Z	2,70	6250	900	2430
WGM450-3.3 EC180/55D3G01- B450/150A2-11-Z	69	74	WGM450-3.3 EC180/55D3G01- B450/150A2-11-Z	3,30	7053	1100	2200
WGM450-5.25 EC180/85D3G01- B450/150A2-11-Z	70,1	73,1	WGM450-5.25 EC180/85D3G01- B450/150A2-11-Z	5,25	8980	1400	2600
WGM225-0.36 EC092-25E3G01- B225-70A2-11-Z	56,9	72,1	WGM225-0.36 EC092-25E3G01-B225- 70A2-11-Z	0,36	970	670	3600
WGM225-0.43 EC092-25E3G01- B250-85A2-11-Z	59,9	74,2	WGM225-0.43 EC092-25E3G01-B250- 85A2-11-Z	0,43	1500	550	3050
WGM250-0.75 EC102-35E3G01- B225-70A2-11-Z	53,8	65,6	WGM250-0.75 EC102-35E3G01-B225- 70A2-11-Z	0,75	1460	910	4500
PARAMETER ACCORDING TO (EU) 327/2011	VALUE						
#3	A						
#4	Static						
#6	Year of manufacture printed on the product nameplate.						
#7	VTS Sp. Z o.o., Al. Grunwaldzka 472A, 80-309, Polska						
#8	YES						
#12	Disposal shall be carried out in an appropriate and environmentally friendly manner in accordance with the laws of the country. "Materials shall be sorted and segregated in an environmentally friendly manner." If necessary, they should be returned to a specialized facility.						
#13	Information provided in the relevant sections of the dedicated manual, especially on maintenance (www.vtsgroup.com)						
#14	N/A						

TECHNICAL INFORMATION FOR REGULATION (EU) No 327/2011 IMPLEMENTING DIRECTIVE 2009/125/EC									
Model:	50/7.5/4 IE3	56/4/4 IE3	56/5.5/4 IE3	56/7.5/4 IE3	56/11/4 IE3	63/4/4 IE3	63/5.5/4 IE3	63/7.5/4 IE3	63/11/4 IE3
1	68,10%	65,70%	66,20%	66,90%	67,50%	64,70%	65,10%	65,70%	66,30%
2	A								
3	Static								
4	62								
5	VSD - yes. Requires installation of speed control for the fan								
6	Specified on the fan nameplate								
7	VTS Sp. z o.o. , 472A Al. Grunwaldzka, 80-309 Gdańsk, Poland								
8	50/7.5/4 IE3	56/4/4 IE3	56/5.5/4 IE3	56/7.5/4 IE3	56/11/4 IE3	63/4/4 IE3	63/5.5/4 IE3	63/7.5/4 IE3	63/11/4 IE3
9	1,503	2,645	2,704	2,673	2,684	4,455	4,812	4,757	4,773
	kW	kW	kW	kW	kW	kW	kW	kW	kW
	5800	8190	8200	8180	8500	11380	12000	11600	11600
	m3/h	m3/h	m3/h	m3/h	m3/h	m3/h	m3/h	m3/h	m3/h
	592	723	744	745	726	876	905	935	945
10	Bye	Bye	Bye	Bye	Bye	Bye	Bye	Bye	Bye
	1455	1440	1455	1455	1460	1414	1455	1455	1460
11	rpm	rpm	rpm	rpm	rpm	rpm	rpm	rpm	rpm
	1								
12	<p>Disassembly of the device should be carried out and/or supervised by appropriately qualified personnel with the appropriate level of expertise. Contact a certified waste disposal organization in your region. Explain what is to follow in terms of the quality of the disassembly of the device and the protection of the components. Disassemble the unit using general procedures commonly used in mechanical engineering.</p> <p>WARNING: The fan assembly consists of heavy parts. These parts may fall during disassembly, which may cause death, serious personal injury or property damage. Be familiar with safety rules</p> <ol style="list-style-type: none"> 1. disconnect the supply voltage including all related circuits. 2. prevent accidental re-engagement. 3 Ensure that the equipment is de-energized. 4. protect or insulate components that are powered and are in the vicinity. To restore power to the system, apply measures in reverse order. <p>Components: The equipment consists mostly of various proportions of steel, copper, aluminum and plastics (rotor made of SAN - styrene, acrylonitrile, structural material with the addition of 20% glass fiber). Components should be sorted when recycled by material: iron and steel, aluminum, copper, non-ferrous metals such as winding (winding insulation will be burned when recycling copper), insulating materials, electrical wiring, electronic waste, plastic components (fan rotor, winding covers, etc.). The same applies to fabrics and cleaning substances that were used during the disassembly of components. Separation of components should be done according to local regulations or by a specialized recycling firm.</p>								
13	The long period of trouble-free operation is dependent on maintaining the product/device/fan within the range of operating parameters specified by the selection program and use in accordance with the intended use specified in the technical and operating documentation supplied with the device. For proper operation and operation of the device, you should also familiarize yourself with the information contained in the technical documentation in the chapters: installation, commissioning, operation and maintenance.								
14	No additional elements								

9.2 RELATED USER MANUALS



- ! Refer to the detailed instructions and make connections and configurations according to the documentation available at www.vtsgroup.com and the instructions supplied with the equipment. In particular, you should familiarize yourself with:
- Control gear for Supply and Supply-Exhaust Air Handling Units / Controls for Supply and Supply-Exhaust Air Handling Units (cg_upc3_controls),
 - Installation, Operation and Maintenance Manual - PCB EC Board for EC motor, uPC3 controller [EN]/EC board for air handling units index 1-2-1209-0062,
 - Installation, Operation and Maintenance Manual - VENTUS Software - uPC3 control / VTS Ventilation Software for air handling units (Ventus - Application uPC3) uPC3 controller - connection diagram,
 - Controls of the modular VENTUS unit - short instruction of wiring, assembling and start-up step by step / Short instruction of assembly, wiring and start-up step by step (VENTUS units equipped with automation in the CBX standard),
 - Installation, Operation and Maintenance Manual VENTUS Heat Wheel Drive / rotary heat exchanger drive manual,
 - Roof assembly / Roof installation
 - Installation Manual Sections Connection / Section Connection Manual,
 - Installation, Operation and Maintenance Manual Vts Ec Motor Drive / Technical Conditions of Drives with EC Motors for VTS Company Equipment,
 - By-pass actuators connection to Premium Cross-Flow Plate Exchanger
 - Installation, Operation and Maintenance Manual - Electric Heater supply and control system/ Electric heater supply and control system Technical and operating documentation,
 - Operation and Maintenance manual - Electric Heaters - Power Slices / Electric heaters - slices Technical and operating documentation.
 - AHU uPC3 Controller Screens Description

9.3 DISMANTLING AND DISPOSAL OF



- ! Disassembly of the device should be carried out and/or supervised by appropriately qualified personnel with the appropriate level of knowledge and authority. A certified waste disposal organization in your region should be contacted. Confirm how to prepare and segregate materials, especially hazardous materials that may have been used in the construction of the appliance (e.g.: batteries).
- ! Components should be sorted for recycling by material: iron and steel, aluminum, copper, non-ferrous metals such as windings (winding insulation will be burned when recycling copper), insulating materials, electrical wiring, electronic waste, plastic components, etc. The same applies to fabrics and cleaning substances that were used during the dismantling of components. Separation of components should be done according to local regulations or by a specialized recycling firm.
- ! Dismantle the device using general procedures commonly used in mechanical engineering, respecting local regulations for disposal and waste management.
- ! Installations for low-moisture (Freon) refrigerants are filled with refrigerants, most often R41A, which cannot escape into the atmosphere. The refrigerant must be recovered in accordance with current regulations (this activity must be carried out by a certified person).



- ! General safety rules should be observed.
- ! Keep in mind:
 - The weight of the device and its components. The device consists of heavy components. These parts may fall during disassembly, which may cause death, serious personal injury or property damage.
 - Disconnecting the supply voltage including all related systems.
 - Prevention of accidental re-engagement.
 - The presence of automation or electronic components, in which electricity can be stored.

GENERAL DISMANTLING PROCEDURE

- Disconnection of all utilities.
- Removal of polite and refrigerating agents from the installation.
- Removal of inspection panels.
- Disassembly of electrical and automation systems.
- Removal of all accessories and components from the control panel
- Disassemble components according to their material of construction.
- Removing the casing.
- Separation of insulation from sheet metal
- Segregation of materials and components by material.
- Transfer of materials for disposal.

9.4 NOTES

Routine inspections, carried out by qualified technical personnel or service personnel authorized by VTS, guarantee long-term, reliable and trouble-free operation of the equipment. Our service personnel are always available to provide support in commissioning, maintenance and in the event of any emergency situation related to the operation of the equipment.

VTS authorized service stations sell spare parts and accessories for our air handling units. When ordering parts, please specify the type of air handling unit, size and series number.

For more information regarding the VTS service network, visit www.vtsgroup.com.



The nameplate of the device includes the sound pressure level LWA (1m) given for a distance of 1m from the device.

To calculate LWA values at a distance of 3m and 5m, use the formula:

- $LWA(3m) = LWA(1m) - 9.54$
- $LWA(5m) = LWA(1m) - 13.98$



Original version of the manual.

VTS reserves the right to make changes without notice



Manufacturer-supplied inverters require the use of filters

MOTOR/WAVE POWER	PFC FILTER MODEL
1.5 kW 3~400V	REO CNW933/6
2.2 kW 3~400V	REO CNW933/8
3.0 kW 3~400V	REO CNW933/10
5.5 kW 3~400V	REO CNW933/12
7.5 kW 3~400V	REO CNW933/16
11.0 kW 3~400V*	REO CNW933/24

- * This equipment complies with IEC 61000-3-12 provided that the SSC short circuit power is greater than or equal to 3.67 [MVA] at the point of contact between the user's power supply and the public system. It is the responsibility of the installer or user of the equipment to ensure, if necessary, after consultation with the distribution network operator, that the equipment is connected only to a power source with an SSC short circuit power greater than or equal to 3.67 [MVA] ."

9.5 EU DECLARATION OF CONFORMITY

DEKLARACJA ZGODNOŚCI UE / EU DECLARATION OF CONFORMITY

My, Producent:
The Manufacturer: VTS Sp. z o.o.
ul. Aleja Grunwaldzka 472A
80-309 Gdańsk, Poland



Strona internetowa:
Website: www.vtsgroup.com

Deklarujemy z pełną odpowiedzialności, że wyroby: Centrale wentylacyjne: VENTUS
We hereby declare that the following products: Air handling units: VENTUS

Modele / Models:
VVS021, VVS030, VVS040, VVS055, VVS075, VVS100, VVS120, VVS150, VVS180, VVS230, VVS300, VVS400, VVS500, VVS650

Rok produkcji: / Year of manufacture: 2026

Numer seryjny: / Serial number: od 8-XXX-26-XXXXX-00001 do 8-AXX-26-XXXXX-99999
(Podano na tabliczce znamionowej/ Specified on the nameplate)

są zgodne w całości z postanowieniami następujących dyrektyw oraz z następującymi normami oraz standardami:
comply with the provisions of the following directives and with the following norms, standards, internal reports:

DYREKTYWY: DIRECTIVES:

2006/42/WE Dyrektywa maszynowa
2006/42/EC Machinery Directive

2009/125/WE Dyrektywa Ekoprojektu
2009/125/EC Ecodesign Directive

2014/30/UE Dyrektywa kompatybilności
elektromagnetycznej
2014/30/EU EMC Directive

2011/65/UE, 2015/863/UE Dyrektywa RoHS
2011/65/EU, 2015/863/EU RoHS Directive

2014/35/UE Dyrektywa niskonapięciowa
2014/35/EU Low Voltage Directive

STANDARDY I SPECYFIKACJE: STANDARDS AND SPECIFICATIONS:

EN ISO 12100:2010 | EN ISO 13857:2019 | EN 60204-1:2018 |
EN 60335-1:2012 | EN 60335-2-40:2024 | EN 50106:2008 | EN
60529::1991+A1:2000+A2:2013

327/2011 | 1253/2014 | EN 13053:2019

EN 62233:2008 | EN 61000-6-2:2019 | EN 61000-6-3:2021

EN IEC 63000:2018

Imię i nazwisko, stanowisko osoby upoważnionej:

Przemysław Kamiński

Name and position of authorized person:

Chief Technology Officer

Miejsce i data: Gdańsk, 2026.02.06:
Place and date

VTS sp. z o.o., Al. Grunwaldzka 472 A, 80-309 Gdańsk | NIP: 5871599675 | REGON: 220079570
Sąd Rejonowy Gdańsk – Północ w Gdańsku, Wydział VII Gospodarczy KRS | KRS: 0000239557

Kapitał zakładowy: 150.000,00 PLN | Nr BDO: 000006509 | www.vtsgroup.com

10 APPENDIX A - UNIT VVS007

The VVS007 ERV unit is designed to handle plant capacities from 600 m³/h to 1350 m³/h. The unit is built with 50mm thick PIR insulation and is equipped with a double filtration system, a high-efficiency heat and moisture recovery system, and high-efficiency fans with EC motors. The unit is optionally supplied with a cooler or heat pipe.

VVS007 ERV



10.1 DIMENSIONS VVS007

FRV SYSTEM (RIGHT-HAND VERSION)

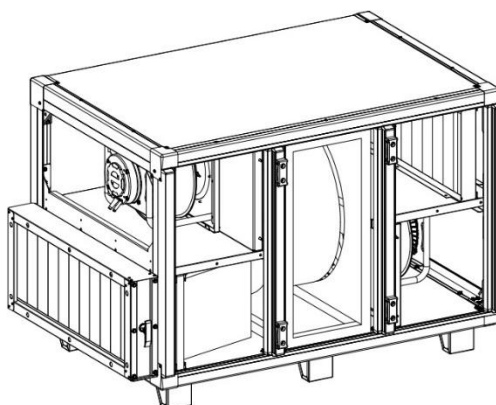
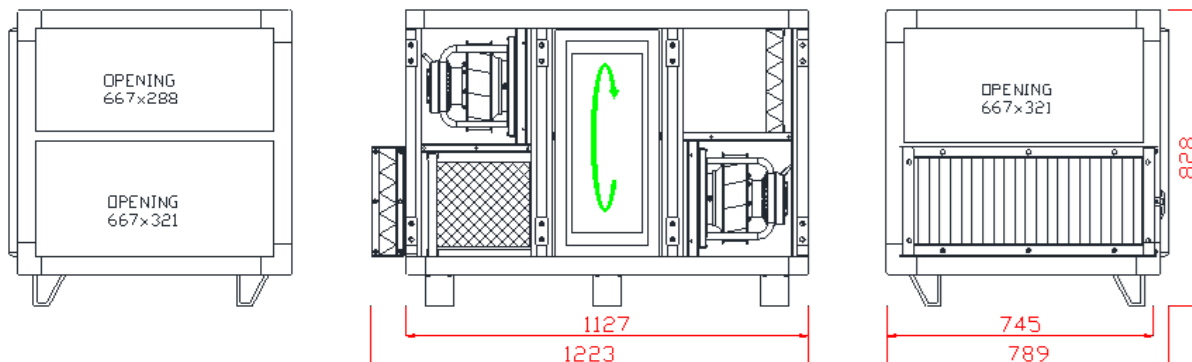

PANEL FOOTPRINT

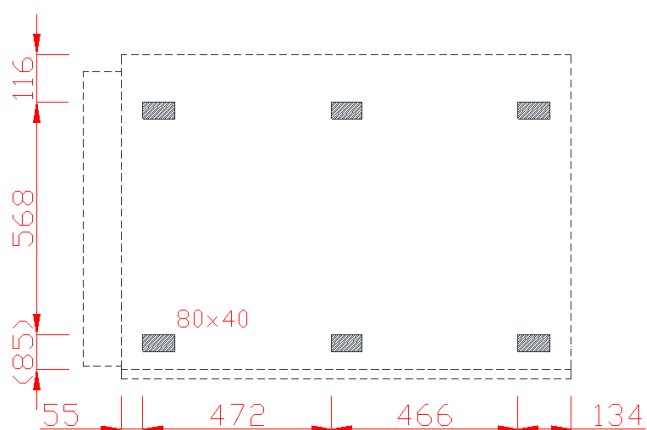

FRCV LAYOUT - FRCV LAYOUT - (2R-4R)

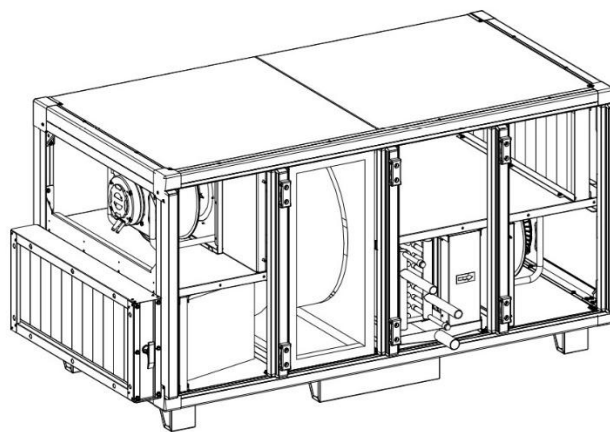
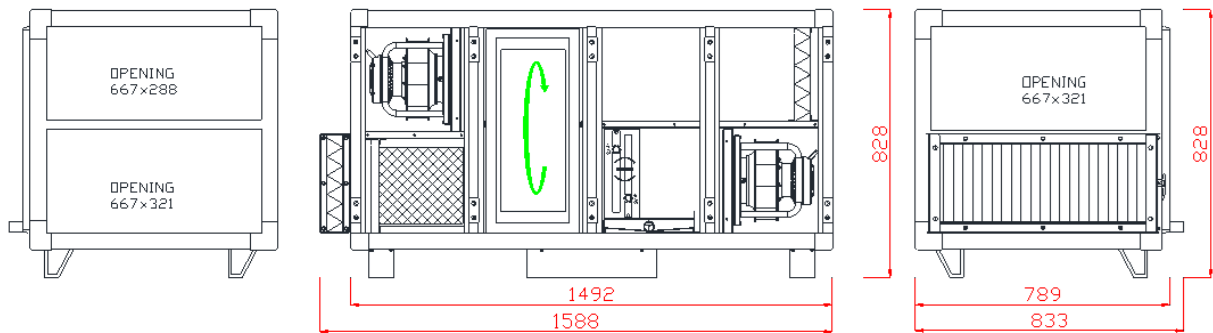

BASE FRAME FOOTPRINT

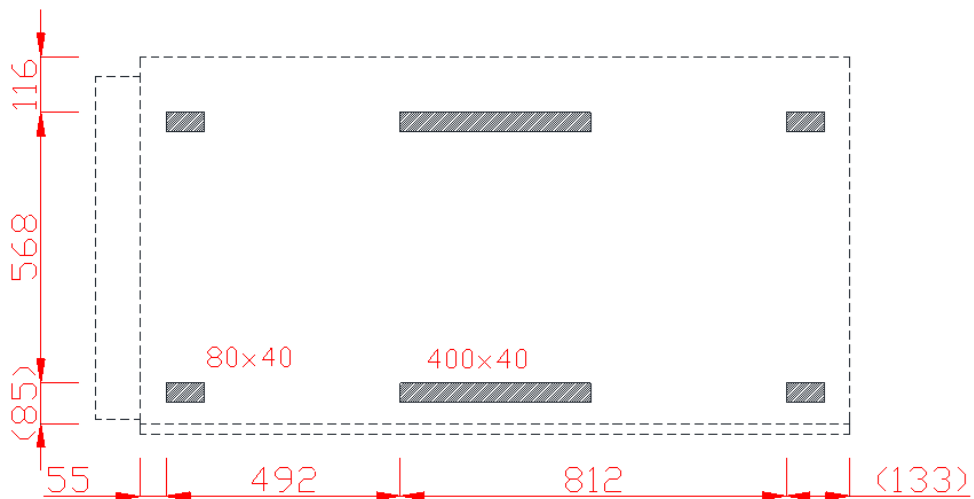

FRCV SYSTEM - (6R-8R)

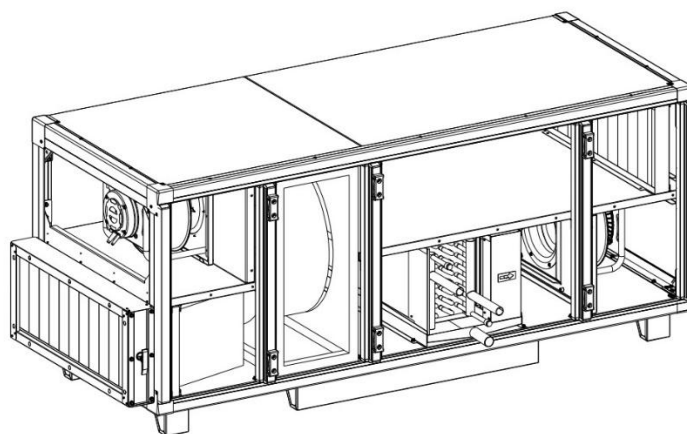
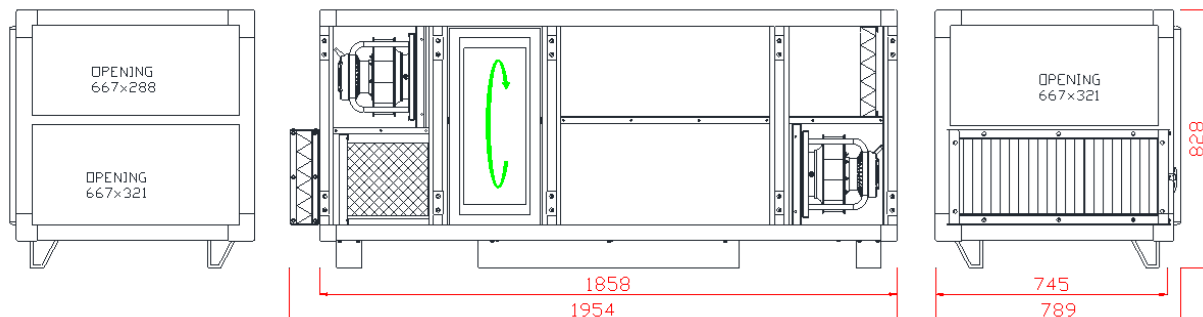

PROJECTION OF THE CONTROL PANEL FEET (FRAME "HV")

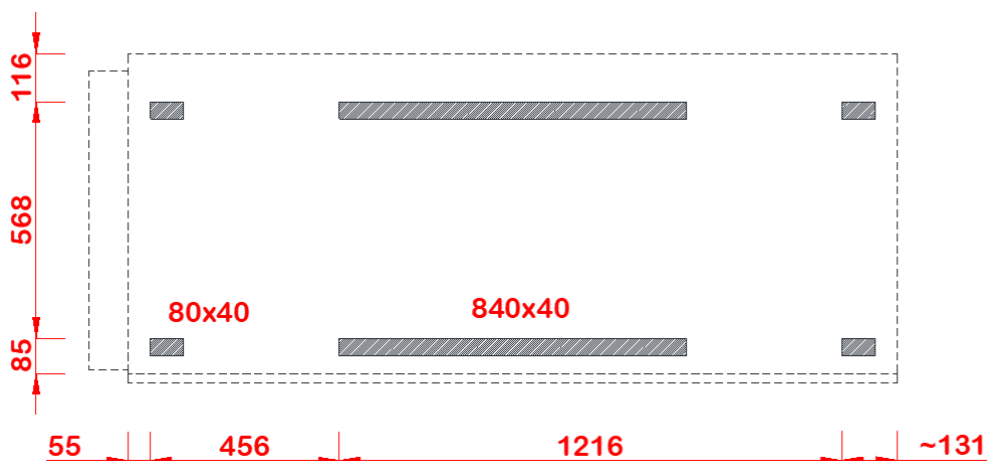

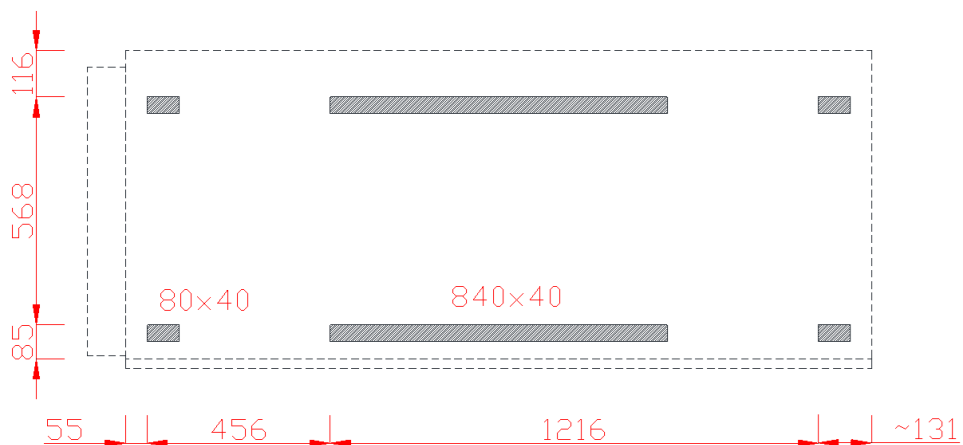

10.2 AIR FILTERS

AIR FILTERS				
	Pos.	Class	Type	A x B x L
	1	Coarse 80%	Plate	690x287x48
	2	ePM10 40%)	Bag	592x287x300

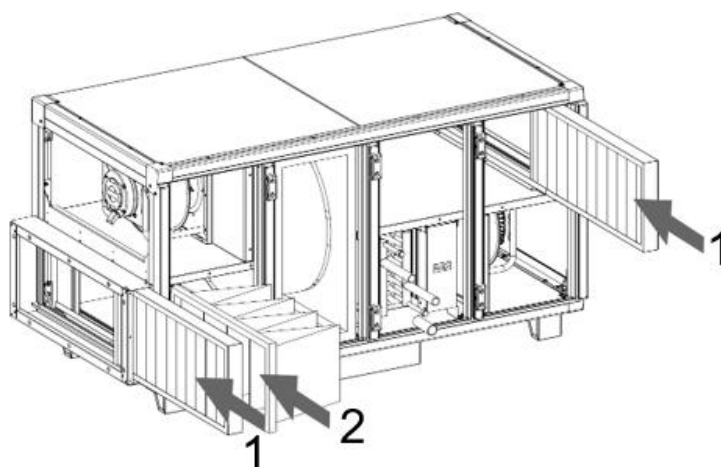

10.3 WATER EXCHANGERS

HYDRONIC COIL											
ROWS	LL	LD	LH	HR	C	HC	TR	D	d	VOLUME	WEIGHT
	[mm]							[inch]		[dm ³]	[kg]
2R	590	692	254	277	37	100	110	3/4"	1/4"	1,4	7,4
3R	590	692	254	277	55	100	110	3/4"	1/4"	2,0	8,7
4R	590	692	254	277	82	100	140	3/4"	1/4"	2,6	10,2
6R	590	692	254	277	137	100	190	3/4"	1/4"	3,9	14,3
8R	590	692	254	277	192	100	250	3/4"	1/4"	4,9	16,4

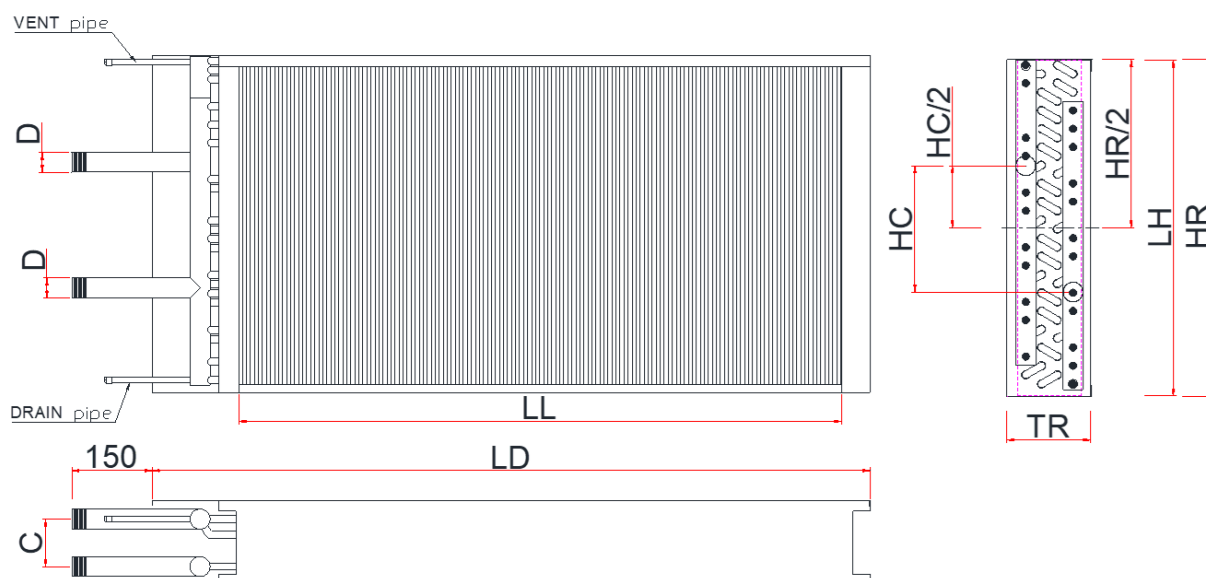

10.4 DX EXCHANGERS

DX COIL													
ROWS	LL	LD	LH	HR	TR	D	E	F	G	ØD IN	ØD OUT	VOLUME	WEIGHT
	[mm]									[inch]		[dm ³]	[kg]
2R	580	692	275	277	110	41	91	75	13	5/8"	Ø28	1,02	5,85
3R	580	692	275	277	140	45	120	75	13	5/8"	Ø28	1,5	6,98
4R	580	692	275	277	170	49	131	75	13	5/8"	Ø28	2,05	8,48
6R	580	692	275	277	235	49	145	75	13	Ø22	Ø28	3,1	11,3
8R	580	692	275	277	260	54	171	75	13	Ø22	Ø28	4,0	13,5

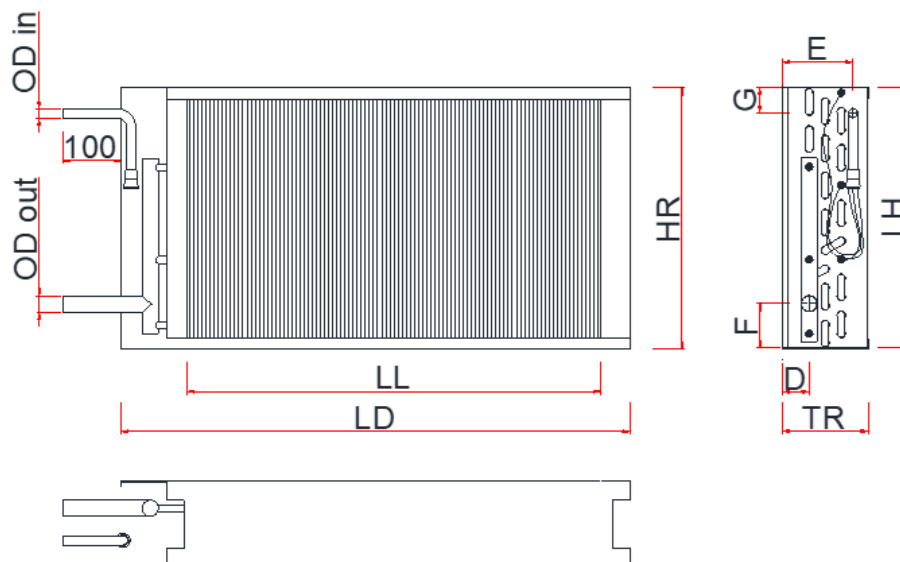

10.5 ROTARY EXCHANGER

TOTAL (ENTHALPY) ROTARY EXCHANGER	W	H	O	D	h	FIN HEIGHT
	[mm]					
VVS007 Small2	695	630	290	300	85	1,6
VVS007 Small	695	630	290	400	85	1,6
VVS007 Standard	695	630	290	500	85	1,6

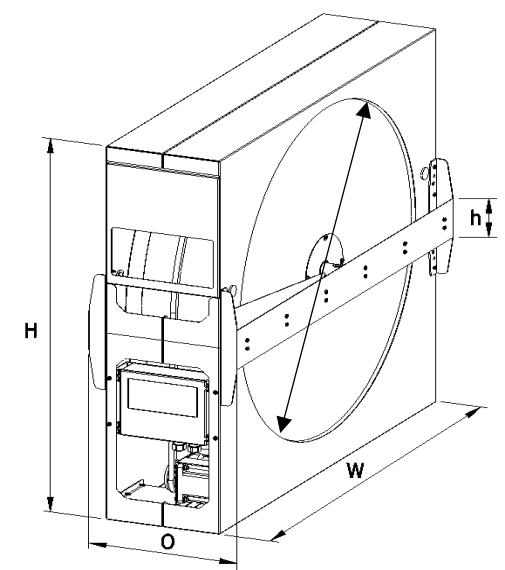

MOTOR	INPUT VOLTAGE	RATED FREQUENCY
[kW]	[V]	[Hz]
0,04	3~230V/400V	50/60