



VENTUS

COMPACT

2022



SUSPENDED AIR HANDLING UNITS

> with counter-flow heat exchanger (hex)

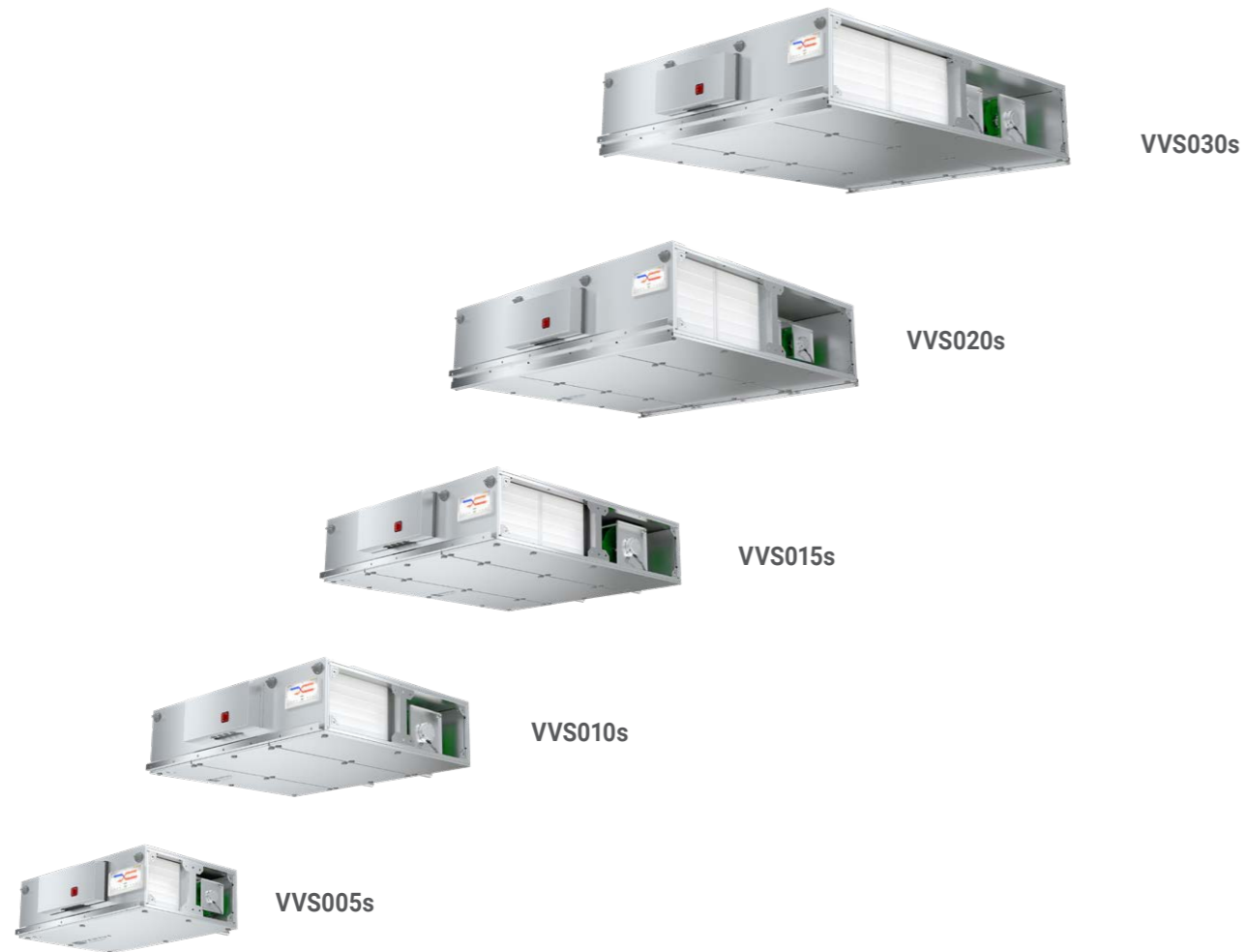

← 150 m³/h - airflow range - 3300 m³/h →

FLOOR MOUNTED AIR HANDLING UNITS

> with rotary heat exchanger or hex counter-flow heat exchanger



← 840 m³/h - airflow range - 16 500 m³/h →

> with rotary heat exchanger and heat pump



← 1 200 m³/h - airflow range - 5 500 m³/h →

> TOP with counter-flow heat exchanger (hex)



← 1 250 m³/h - airflow range - 4 000 m³/h →

ADDITIONAL AIR TREATMENT FUNCTIONS



VENTUS COMPACT SUSPENDED AIR HANDLING UNITS



up to **90%**
recovery efficiency



VENTUS COMPACT FLOOR MOUNTED AIR HANDLING UNITS



up to **90%**
recovery efficiency



up to **90%**
recovery efficiency



VENTUS Compact TOP
with hex counter-flow
heat exchanger

VENTUS Compact
with rotary heat exchanger
or hex counter-flow heat exchanger



MINERAL WOOL
INSULATION



HIGHLY EFFICIENT
HEX COUNTER-FLOW
HEAT RECOVERY



ENERGY SAVING
AND SILENT FANS WITH
EC MOTORS



PLUG&PLAY
PRODUCT



INTEGRATED
MULTIFUNCTIONAL
CONTROLS



MINERAL WOOL
INSULATION



HIGHLY EFFICIENT ROTARY
AND HEX COUNTER-FLOW
HEAT EXCHANGER



ENERGY SAVING
AND SILENT FANS WITH
EC MOTORS



PLUG&PLAY
PRODUCT

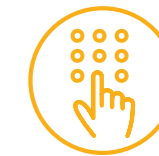

INTEGRATED
MULTIFUNCTIONAL
CONTROLS

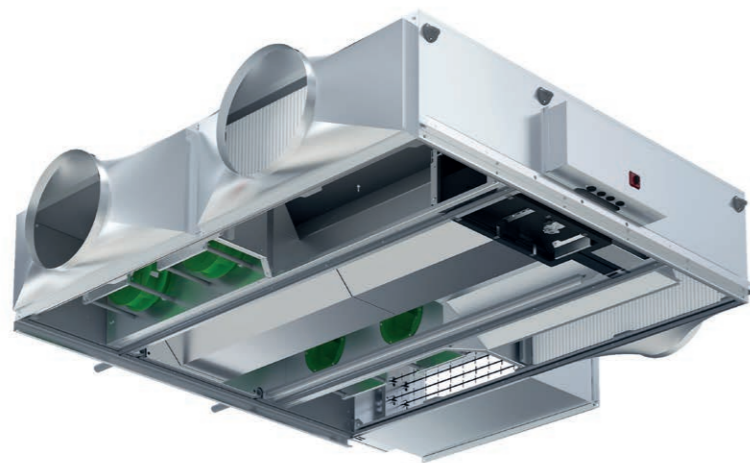

> VENTUS Compact



0,5L

> Standard Air Handling Units



1L

VENTUS COMPACT SUSPENDED AIR HANDLING UNITS

CASING

- » Panels filled with mineral wool, enclosed with steel sheet on both sides.
- » Casing parameters according to EN 1886: T2, TB3, L1, D1, F9.

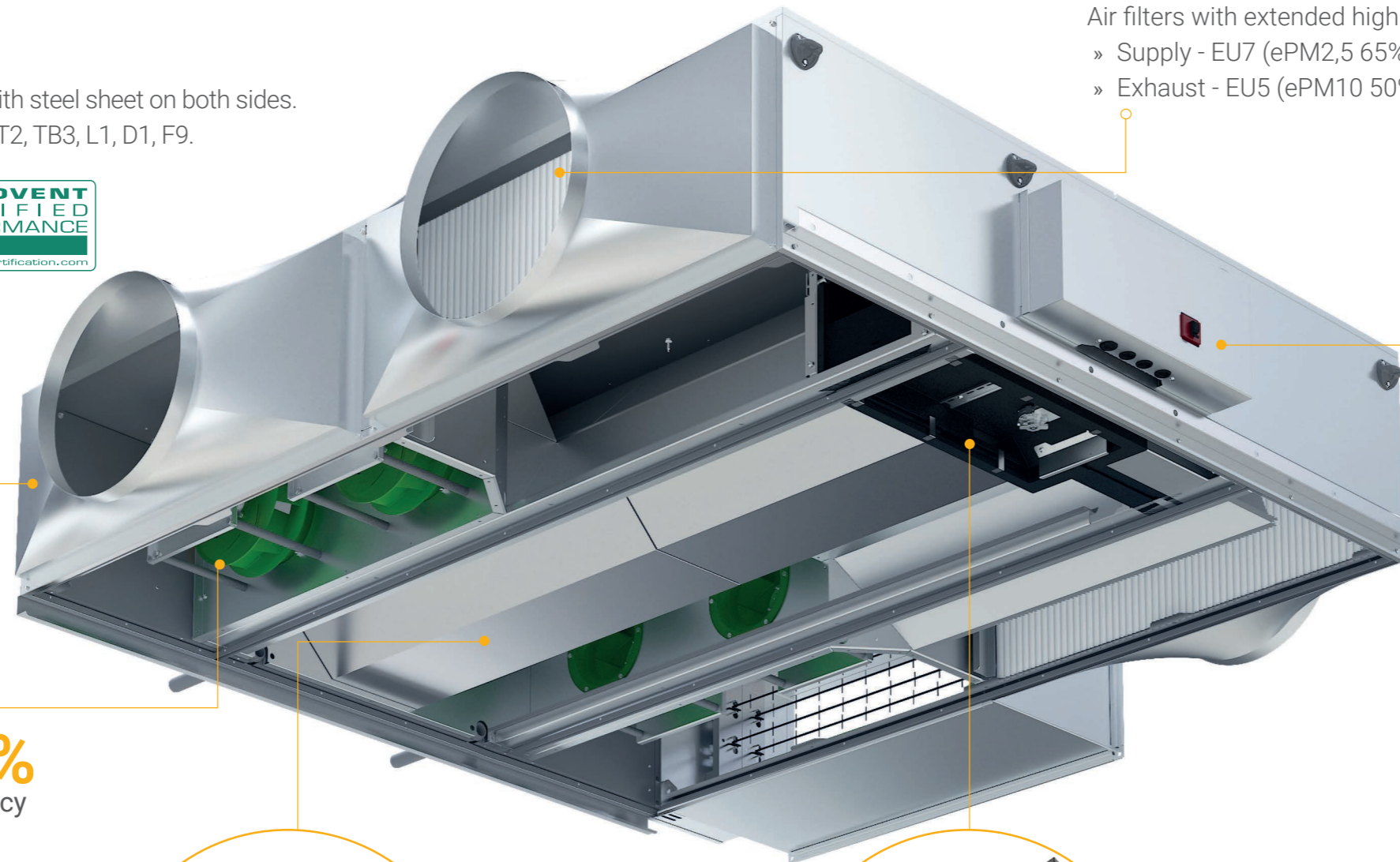

MINI-PLEAT FILTERS

- Air filters with extended high efficiency filtration surface.
- » Supply - EU7 (ePM2,5 65%)
 - » Exhaust - EU5 (ePM10 50%)



up to **93%**
drive efficiency



EC MOTORS

- » Efficient, silent and low vibrations fan with electronically commutated motor in a IE4 class.

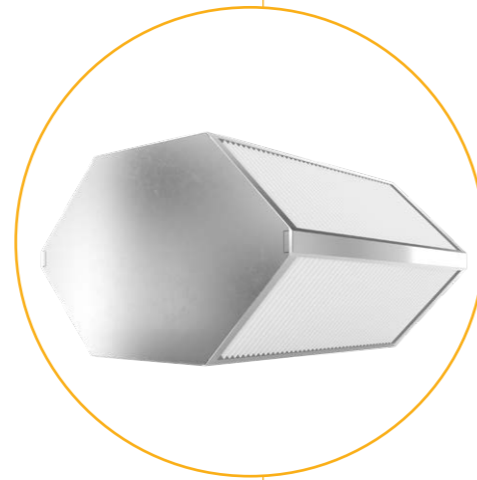

ENERGY RECOVERY

- » Highly efficient counterflow hex recovery with by-pass.
- » Recovery efficiency reaching 90%.

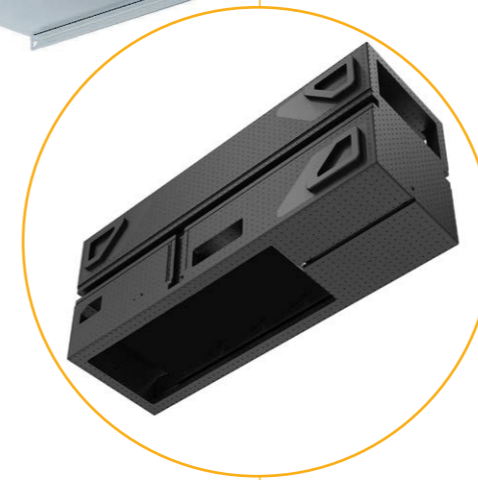

RECUPERATOR BY-PASS

- » Stepless adjustment of heat recovery capacity.
- » Passive cooling function.
- » Recuperator frost protection.

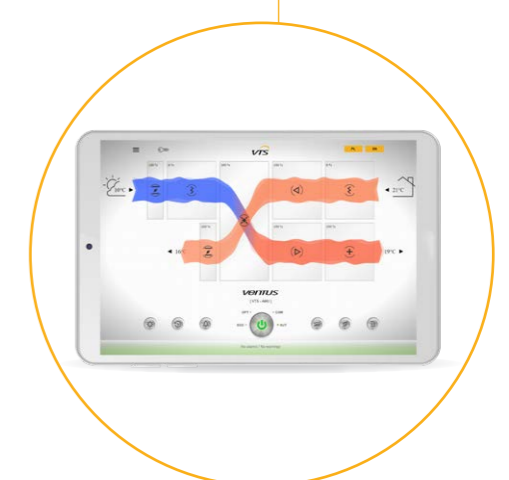

CONTROLS

- » Multifunctional controls, integrated with the unit – fully pre-configured and ready to run.

VENTUS COMPACT TOP FLOOR-MOUNTED UNITS WITH VERTICAL DUCT CONNECTION

CASING

- » Panels filled with mineral wool, enclosed with steel sheet on both sides.
- » Casing parameters according to EN 1886: T2, TB3, L1, D1, F9.
- » Fan and filter section panels fitted with hinges.



DIMENSIONS

- » Unit width 88 cm - can be transported through the opening of 90 cm without disassembling the device.

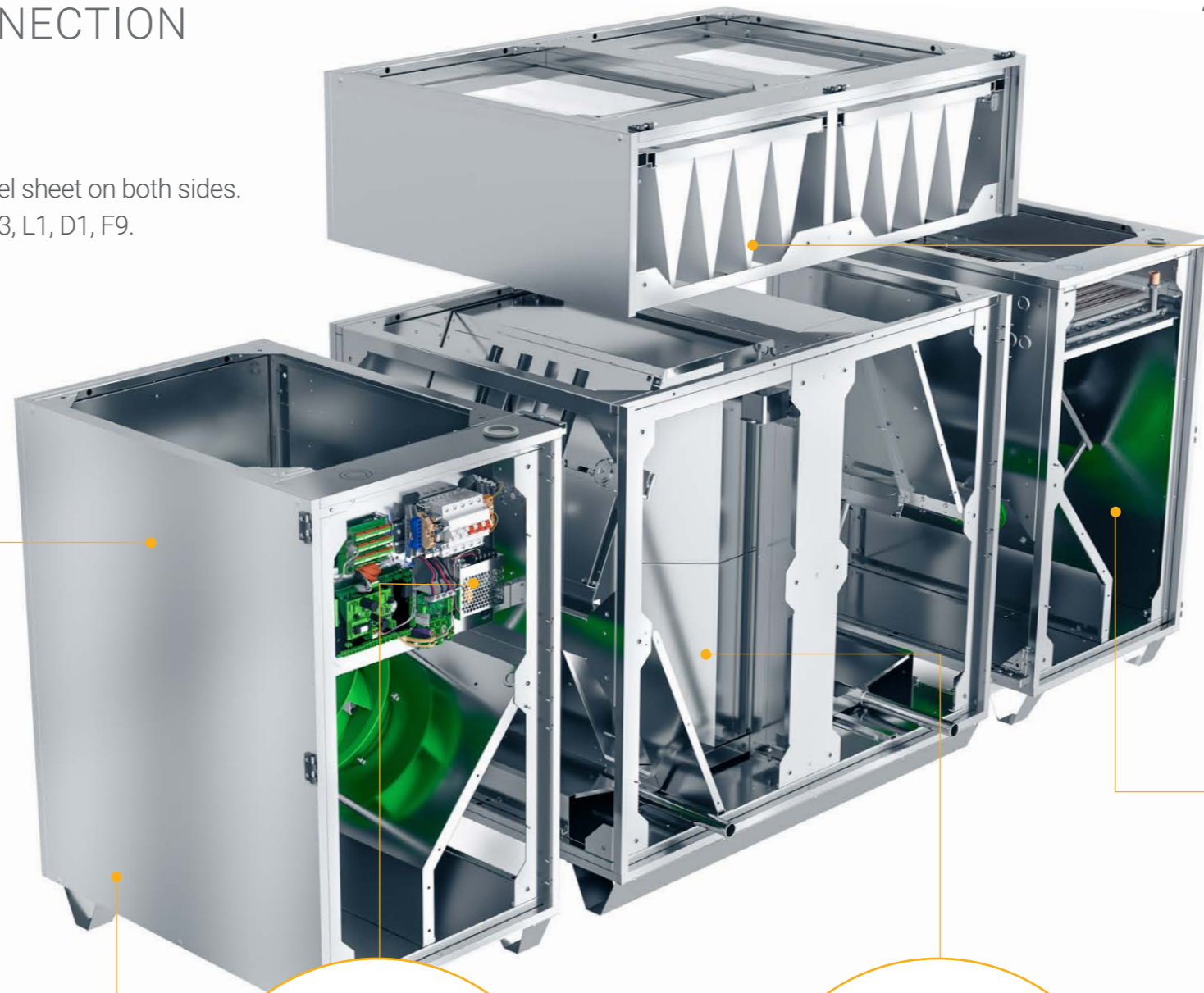

MINI-PLEAT OR BAG FILTERS

Air filters with extended high efficiency filtration surface.

- » Supply - EU7
- » Exhaust - EU5

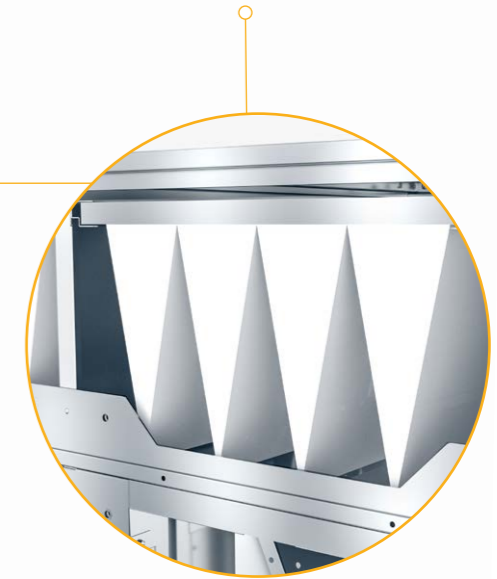

CONTROLS

- » Multifunctional controls, integrated with the unit – fully pre-configured and ready to run.



ENERGY RECOVERY

- » Highly efficient counterflow hex recovery with by-pass.
- » Recovery efficiency reaching 90%.



EC MOTORS

- » Efficient, silent and low vibrations fan with electronically commutated motor in a IE4 class.

VENTUS COMPACT FLOOR MOUNTED AIR HANDLING UNITS

CASING

- » Panels filled with mineral wool, enclosed with steel sheet on both sides.
- » Casing parameters according to EN 1886: T2, TB3, L1, D1, F9.

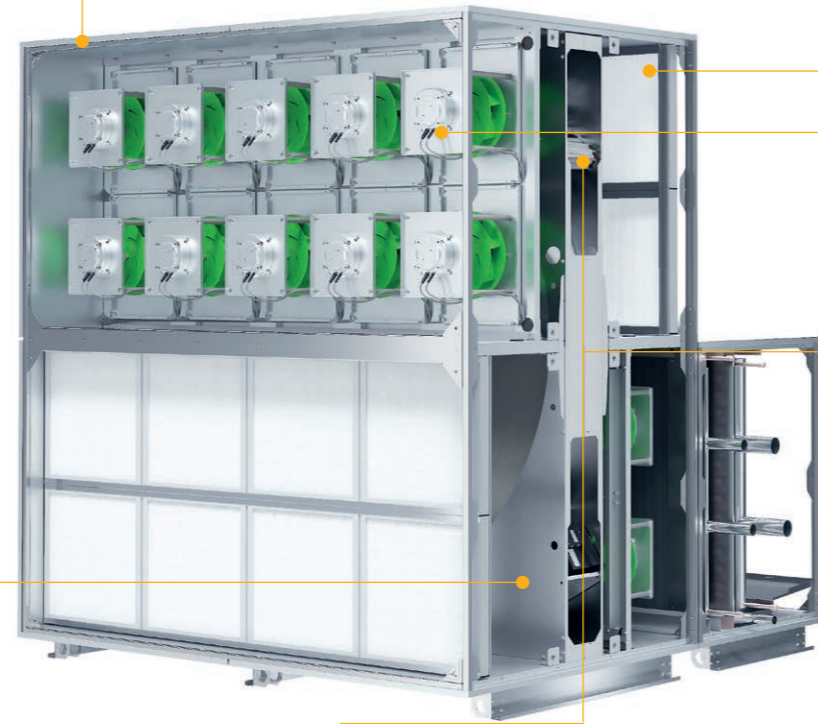

MINI-PLEAT FILTERS

- Air filters with extended high efficiency filtration surface.
- » Supply - EU7 (ePM2,5 65%)
 - » Exhaust - EU5 (ePM10 50%)

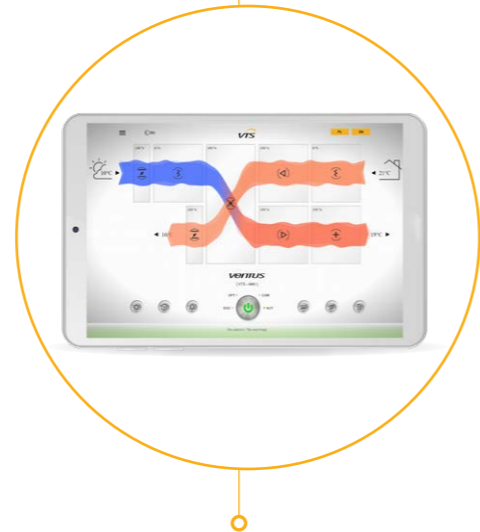
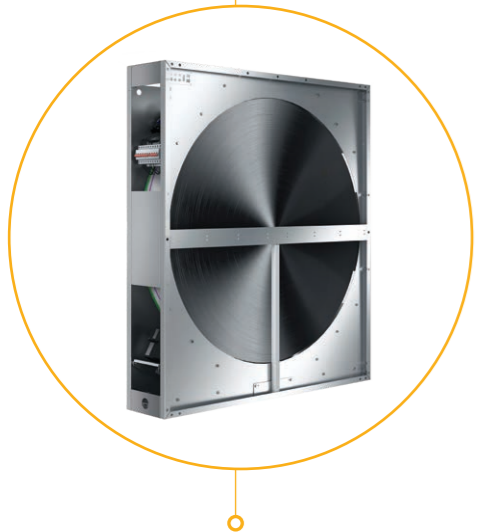
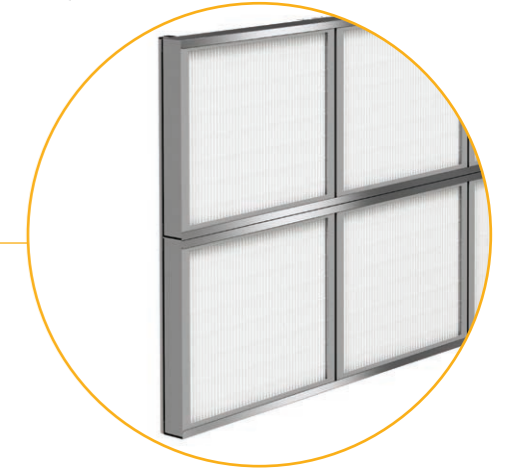

up to **93%**
drive efficiency

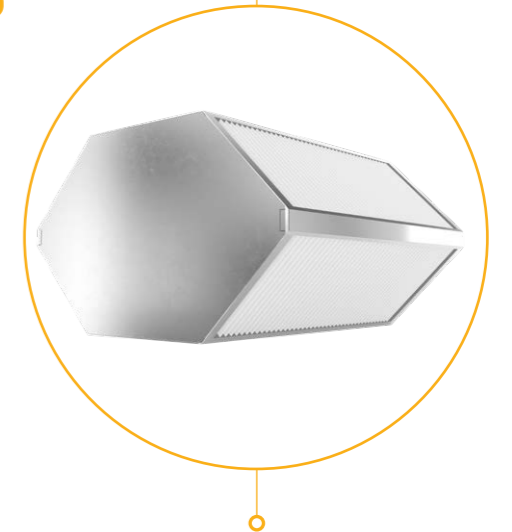

ENERGY RECOVERY

- » Highly efficient heat wheel driven by EC motor.
- » Recovery efficiency reaching 86%.

CONTROLS

- » Multifunctional controls, integrated with the unit – fully pre-configured and ready to run.

EC MOTORS

- » Efficient, silent and low vibrations fan with electronically commutated motor in a IE4 class.

ENERGY RECOVERY

- » Highly efficient counterflow hex recovery with by-pass
- » Recovery efficiency reaching 90%

VENTUS COMPACT FLOOR MOUNTED UNITS WITH HEAT PUMP

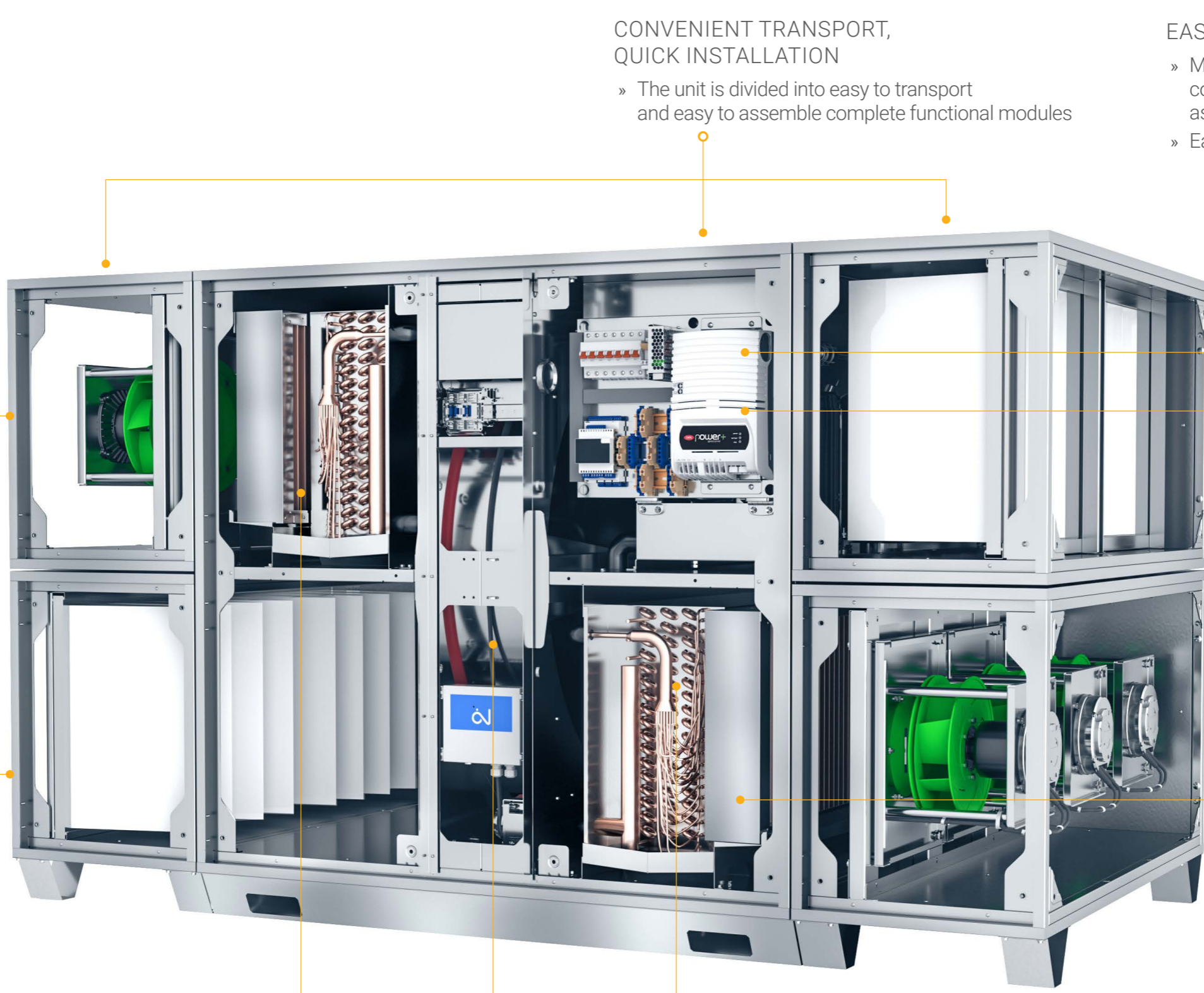

FOR USE IN ANY FACILITY

- » No external refrigeration equipment taking up space in your facility
- » No external noise sources

OPTIMUM MATCHING

- » Factory fit of heat pump and air handling unit components
- » Manufacturer's warranty on the final air handling unit and heat pump product

HIGH ENERGY EFFICIENCY

- » High efficiency sorption rotary regenerator for excellent heat and moisture recovery
- » Installation of multi-row condensers and evaporators on both sides of the regenerator ensures the most efficient operation of the heat pump

CONVENIENT TRANSPORT, QUICK INSTALLATION

- » The unit is divided into easy to transport and easy to assemble complete functional modules

EASY COMMISSIONING

- » Multifunctional factory assembled controls ready to work as soon as the unit is assembled
- » Easy commissioning without service

COHERENT CONTROL SYSTEM

- » Integrated control system for air handling unit and heat pump
- » Full monitoring and remote diagnostics of all components

HEAT PUMP FUNCTIONS

- » Supply air cooling in summer
- » Reduction of supply air heating costs during other periods of the year

VENTUS COMPACT FLOOR MOUNTED UNITS WITH HEAT PUMP

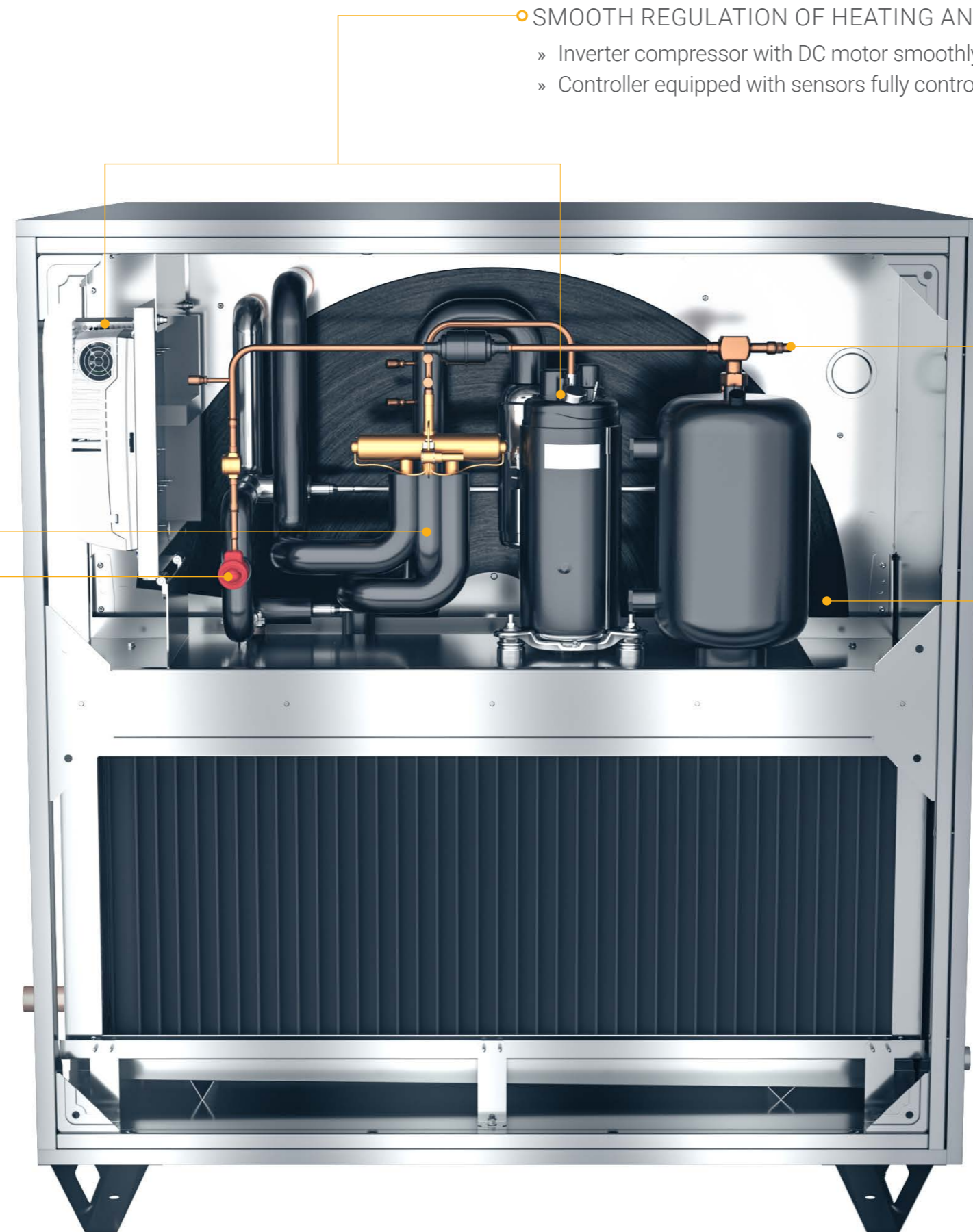

HEATING AND COOLING FUNCTION

- » Four-way valve automatically switches reverse operation modes
- » Automatic defrosting function in winter

OPTIMISATION OF COOLING PARAMETERS

- » Electronic expansion valve dynamically adjusts fluid flow to current air handling unit parameters

SMOOTH REGULATION OF HEATING AND COOLING POWER

- » Inverter compressor with DC motor smoothly adjusts cooling and heating power
- » Controller equipped with sensors fully controls cooling parameters of the heat pump system

MULTI-STAGE HEAT PUMP QUALITY CONTROL

- » Ongoing monitoring of the production process
- » Individual leakage and operational check confirmed by electronic report
- » UDT (Office of Technical Inspection) certificate

SMOOTH REGULATION OF HEAT RECOVERY POWER

- » Electronically controlled stepper motor of the rotary heat exchanger smoothly regulates heat recovery capacity
- » In winter time the automation system ensures three-stage frost protection for the rotary heat exchanger

VENTUS COMPACT SUSPENDED AIR HANDLING UNITS

Base unit overall data

Unit size	Nominal airflow	Airflow range	Height	Width	Duct connection height	Duct connection width
	[m³/h]	[m³/h]	[mm]	[mm]	[mm]	[mm]
VVS005s	500	150 - 650	400	790	318	335
VVS010s	1000	300 - 1100	400	1150	318	515
VVS015s	1500	450 - 1650	400	1550	318	715
VVS020s	2000	600 - 2200	490	1610	408	743
VVS030s	3000	900 - 3300	490	2160	408	1018

Section length

Unit size		F	H	C	HC
	Base unit	Additional air treatment functions			
	[mm]	[mm]	[mm]	[mm]	[mm]
VVS005s	1230	200	200 - 460	370 - 460	460 - 920
VVS010s	1500	200	200 - 460	370 - 460	460 - 920
VVS015s	1500	200	200 - 460	370 - 460	460 - 920
VVS020s	1828	200	200 - 460	370 - 460	460 - 920
VVS030s	1828	200	200 - 460	370 - 460	460 - 920

Duct accessories

Dimension WxH [mm]	VVS005s	VVS010s	VVS015s	VVS020s	VVS030s
Flexible connection	305x288	485x288	685x288	730x375	1005x375
Air damper	305x288	485x288	685x288	730x375	1005x375
Rectangle spigot	330x310/300x300	510x310/400x350	710x310/400x350	740x400/500x400	1015x400/800x400
Rounded spigot	330x310/355	510x310/355	710x310/355	740x400/450	1015x400/450





VENTUS COMPACT FLOOR MOUNTED AIR HANDLING UNITS

Base unit overall data

Unit size	Nominal airflow	Airflow range	Height	Width	Duct connection height	Duct connection width
	[m³/h]	[m³/h]	[mm]	[mm]	[mm]	[mm]
VVS021c	2100	840 - 2310	991	967	345	860
VVS030c	3000	900 - 3300	1255	967	480	860
VVS040c	4000	1200 - 4400	1255	1174	480	1065
VVS055c	5500	1650 - 6050	1525	1345	615	1235
VVS075c	7500	2250 - 8250	1765	1486	735	1380
VVS100c	10000	3000 - 11000	1965	1666	835	1560
VVS120c	12000	3600 - 13200	2039	1897	870	1790
VVS150c	15000	4500 - 16500	2241	2091	970	1985

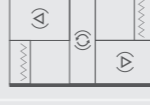
Height includes 90 mm base rail

Base unit lengths

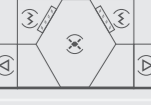
Unit size						
	[mm]	[mm]	[mm]	[mm]	[mm]	[mm]
VVS021c	1240	1080	1080	2 230	2 230	2 500
VVS030c	1240	1080	1080	2 230	2 230	2 500
VVS040c	1240	1080	1080	2 230	2 230	2 500
VVS055c	1240	1080	1080	2 290	2 290	2 560
VVS075c	1240	1080	1080	2 530	2 530	2 800
VVS100c	1300	1300	1080	2 570	2 570	2 800
VVS120c	1300	1300	1080	2 670	2 670	2 900
VVS150c	1300	1300	1080	2 730	2 730	2 940

Additional section length

Unit size	F	H	C	HC	S
	[mm]	[mm]	[mm]	[mm]	[mm]
VVS021c	310	310 - 710	370 - 710	710	1080
VVS030c	310	310 - 710	370 - 710	710	1080
VVS040c	310	310 - 710	370 - 710	710	1080
VVS055c	310	310 - 630	450 - 790	790	1080
VVS075c	310	310 - 630	450 - 790	790	1080
VVS100c	310	310 - 630	890	890	1080
VVS120c	310	310 - 630	890	890	1080
VVS150c	310	310 - 630	920	920	1080

VENTUS COMPACT TOP - FLOOR-MOUNTED UNITS WITH VERTICAL DUCT CONNECTION

Base unit overall data

Unit size	Nominal airflow	Airflow range	Height	Width	Duct connection
	[m³/h]	[m³/h]	[mm]	[mm]	[mm]
VVS023c	2100	1250-2100	1176	880	700x445
VVS033c	3000	1800-3000	1447	880	700x513
VVS043c	4000	2400-4000	1737	880	700x613

Base unit lengths

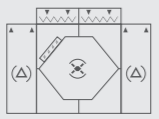
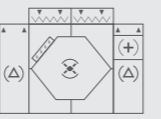
Unit size		
	[mm]	[mm]
VVS023c	2100	2100
VVS033c	2460	2460
VVS043c	2860	2860

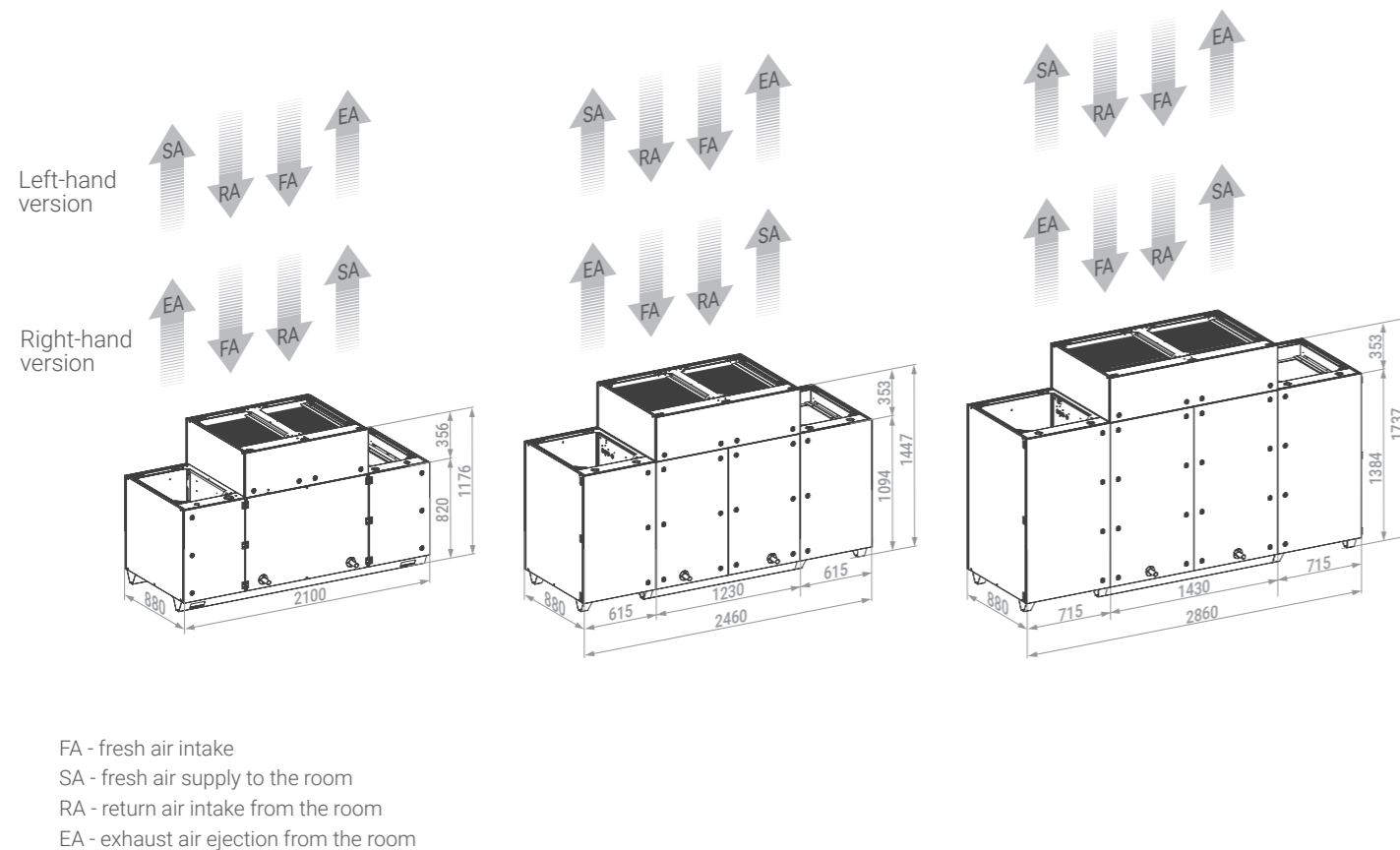



VENTUS COMPACT - FLOOR MOUNTED UNITS WITH HEAT PUMP

Base unit overall data

Unit size	Nominal airflow	Airflow range	Height	Width	Duct connection height	Duct connection width
	[m³/h]	[m³/h]	[mm]	[mm]	[mm]	[mm]
VVS021c	2100	1200-2100	991	967	345	860
VVS030c	3000	1500-3000	1255	967	480	860
VVS040c	4000	2000-4000	1255	1174	480	1065
VVS055c	5000	2500-5500	1525	1345	615	1235

* - the range of the heat pump function depends on the outdoor air parameters

Base unit lengths

Unit size		
	[mm]	[mm]
VVS021c	2660	2400
VVS030c	2660	2400
VVS040c	2660	2660
VVS055c	2820	2820

Heat pump refrigeration system

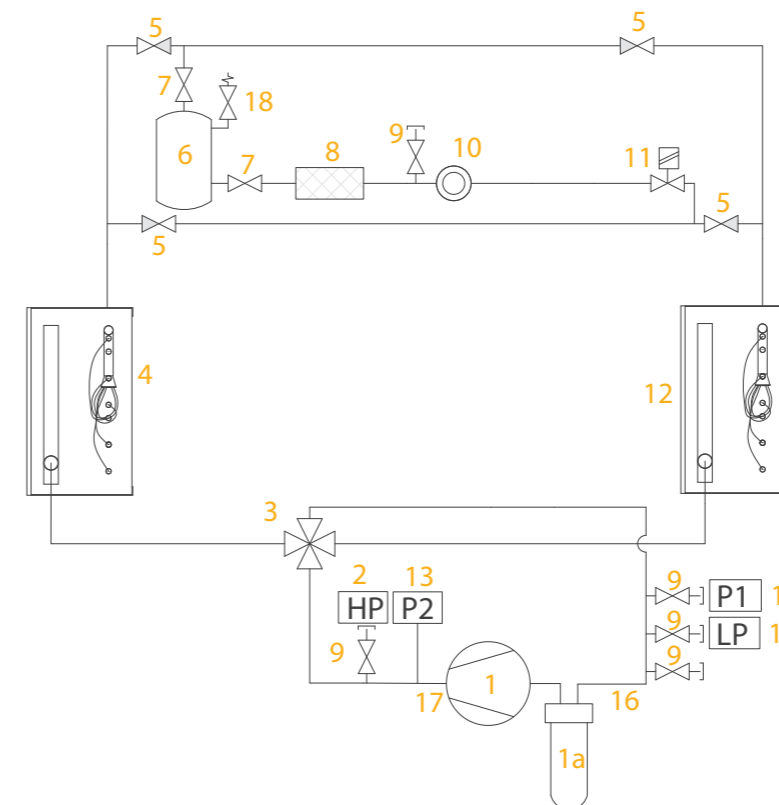

Refrigeration components

- 1 Compressor
- 1a Liquid separator
- 2 High pressure switch
- 3 4-way valve
- 4 Evaporator/Condenser
- 5 Check valve
- 6 Liquid medium tank
- 7 Shut-off valve (Rotalock)
- 8 Filter drier
- 9 Service valve
- 10 Sight glass
- 11 Electronic expansion valve
- 12 Evaporator/Condenser
- 13 High-pressure transducer
- 14 Low-pressure transducer
- 15 Low-pressure switch
- 16 Suction temperature sensor
- 17 Discharge temperature sensor
- 18 Safety valve

VMS – VENTUS MANAGEMENT SYSTEM

VTS supplies control system with a factory-implemented application for remote monitoring and management of the operating parameters of the units in real time via a web browser on any mobile device.

VENTUS MANAGEMENT SYSTEM:

- » Displaying visualisations on any devices - from PC to mobile devices
- » Monitoring and management of the majority of devices from the open visualisation of a single unit
- » Easy and intuitive change of the operating mode of the unit using a central button
- » Tools for supporting easy and quick setup of the optimal operating schedule of the unit



Graphical operation calendar:

- » Changing time intervals using sliders



Faults and alarms handling:

- » Clearing alarms
- » Alarm logging

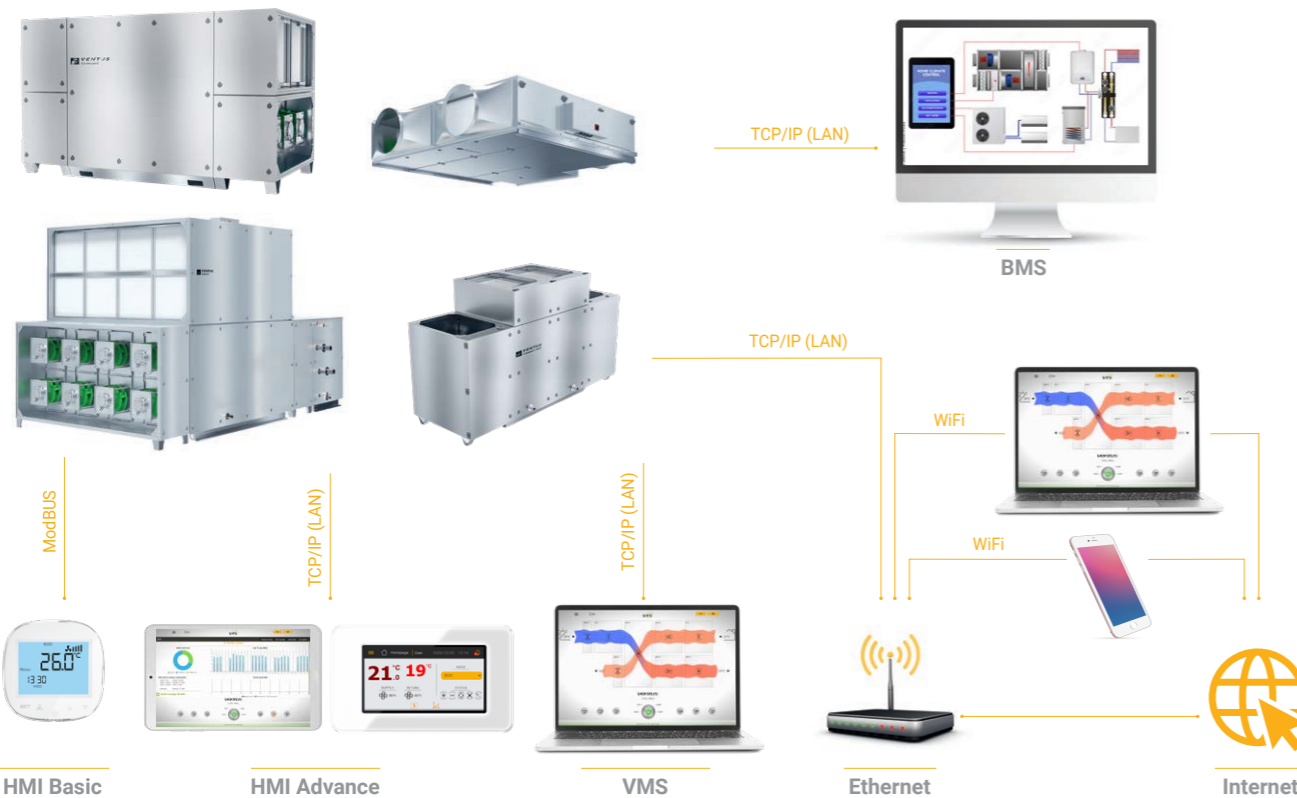

Charts of unit's operation:

- » Two charts – main and secondary
- » Free selection of the set of parameters for monitoring and assigning them to selected ranges



Analysis of savings resulting from the operating scenario used:

- » Graphical representation of the use of particular energy media
- » Costs and savings shown in any currency.

CLIMACAD ONLINE 4.0 (CCOL 4)

Customized configuration

Integrated savings calculator

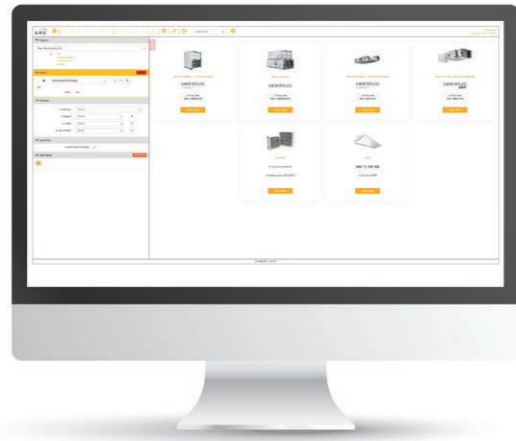

Intuitive selection assistant step by step

Integrated with CRM, ERP, WMA system

CCOL4 IS COMPATIBLE WITH:

» all browsers



» all operating system



» all devices



DATA EXPORT TO



VTS BIM - INNOVATIVE APPROACH TO DIGITAL MODELS OF AIR-HANDLING UNITS

VTS has created a possibility of dynamic online generation of digital models of the units VENTUS VVS, VENTUS Compact and American VENTUS AVS. This is possible due to the launch of the new ClimaCAD OnLine 4.0 product selection program that features an .rfa [Revit®] file generator

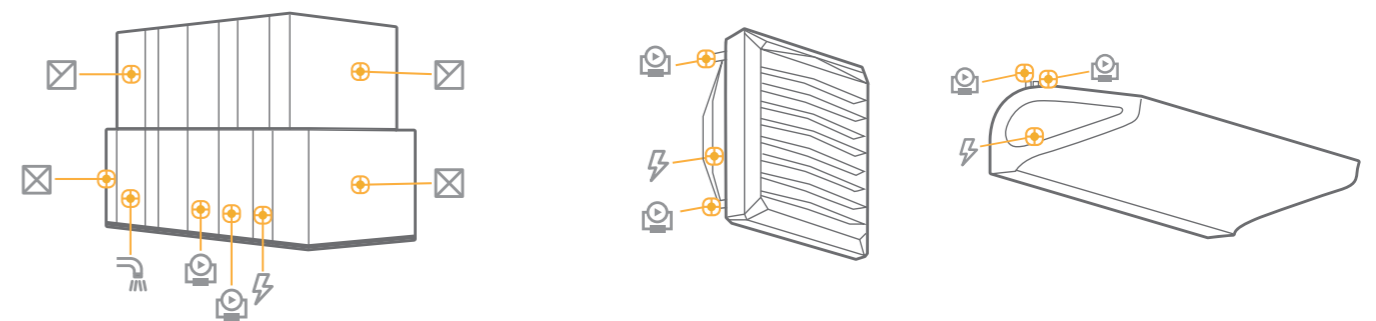
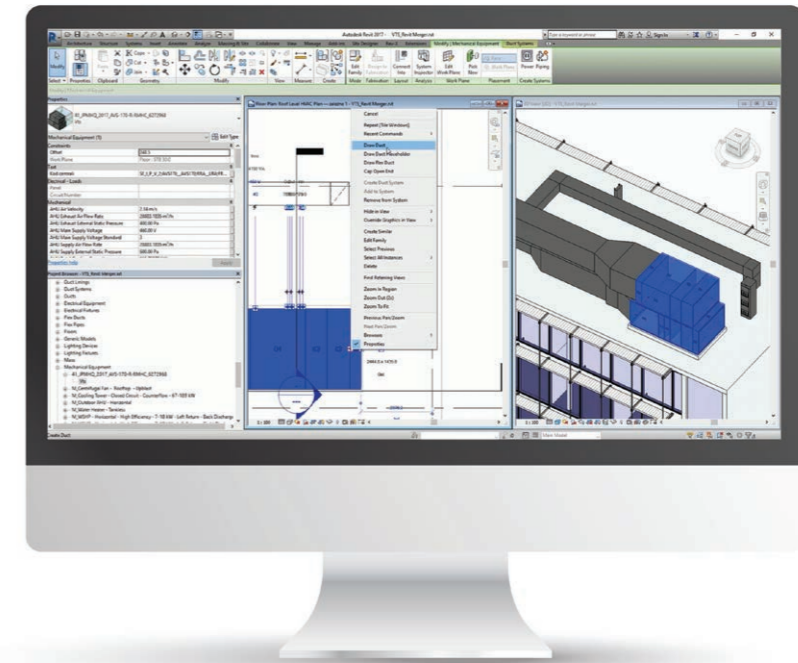

Generated objects contain detailed parameters connectors:

- » air systems
- » hydraulic systems
- » sanitary systems
- » electric systems

as well as the complete dimensional data, including unit's maintenance and service (repair) zone.

VTS also provides digital models of WING air curtains and VOLCANO air heaters.

The models contain:

- » parametrized electric and hydraulic connectors,
- » mount options vertically and horizontally,
- » presentation of the range of air stream,
- » parameter of any inclination angle of an air heater in relation to the horizontal plane.

Models can be downloaded from: <https://vtsgroup.com/vts-bim>



VTS Group S.A.

20, rue de l'Industrie
L-8399 Windhof, Luxembourg
Phone: +352 20 60 22 41
Email: contact@vtsgroup.lu

www.vtsgroup.com

Due to continuous improvement of the products, VTS reserves right to implement modifications. Some of technical data and descriptions may vary from the actual products specification. Before placing the order, please, confirm all technical specification with VTS sales representative.