



PRODUCT CATALOGUE

Air Handling Units

ventus BORN IN THE USA



Low weight



Innovative FRAMELESS casing



Maintenance-free PLENUM fan

VTS ensures TOP Quality





Addresses:

VTS America Inc.

1650 Horizon Parkway NE, Suite 100
 Buford, GA 30518
 Tel.: +1 470-809-6811
 Fax: +1 470-809-6815
 e-mail: america@vtsgroup.com
 www.vtsgroup.com

VTS Sales Representatives

Midwest Region

Tel. +1 470-428-6517

Northeast Region

Tel. +1 470-767-4402

Southeast Region

Tel. +1 470-428-6165

Index

VTS

World inspires us	2
VTS Group – a leader in HVAC sector	3
Dynamic long term growth	4
ClimaCAD On-line	5
Quality First	6
Reliable Business Partner	7

VENTUS

Product introduction	8
Typical applications	9
VTS Air Handlers Family	10
Symbols and labels	11
Configurations	12
Air intake, Air discharge configurations	14
Horizontal Air Handlers	14
Vertical Air Handlers	15
Energy Wheel Air Handlers	16
Cross Plate Air Handlers	17

Functions

Casing	18
Direct Driven Plenum Fans	18
Variable Frequency Drives	19
Filters	20
Cooling Coils	20
Hot Water Heating Coil	20
Electric heaters	21
Steam Coil	21
Cross-Flow Plate	21
Energy Wheel	22
Mixing Box	22

Controls

Control Elements	26
Control Applications List	32
Control applications	32
Fan Curves	40

A presence in
40
countries

Across
5
continents



630,000
devices
sold

350
technical sales
consultants

World inspires us



VTS Group – a leader in HVAC sector

VTS Group is a global corporation, a trusted brand and a leading supplier of air conditioning units and heating appliances, focused on offering innovative products at competitive prices with a quick turn-around.

The company is the No. 1 provider of Air Handling Units in Europe and leading provider in the world with established platforms across quickly developing markets of the Emirates, China and India, and network of sales representatives in USA.

VTS offers streamlined, flexible and innovative AHU with a wide range of applications and heating appliances covering market needs delivered in superb short lead time.



Market leader focused on dynamic long term growth

The innovation of the VTS Group model consists in moving the production into the Production Plants where the whole manufacturing process takes place according to the modern business model of VTS Group.

The high quality of the VTS units is the result of the strict and up to date procedures developed by VTS Group and independent international leading expert laboratories.

Innovative technology

Flexible and innovative product design with a wide range of applications addressing the market.

- frameless casing, eliminating thermal bridges
- composite PLENUM fan characterized by increased parameters and reduced costs.
- new product options – constant development of new models tailored to specific market needs.

Advanced Supply Chain Management

Components storage in 5 Production Plants located in Poland, India, UAE, China and USA, allowing quick delivery of products to final customers - almost 75% of orders are sent within short lead time of 1 week.

Long term relationship and cooperation with leading component manufacturers, service companies, retail chains and HVAC dealers from Europe and Asia.

Research & Development Team

People are the innovative strength of VTS Group. Passion and willingness to reach for more makes VTS a solid and global company that is always one step ahead. The Research & Development team create the new dimension of product and services.

ClimaCAD On-line. User friendly on-line AHU selection tool

The Group's sales and distribution network is based on experienced technical sales consultants who interact directly with clients regarding all enquiries through ClimaCAD On-line.

Proprietary software enables an easy-to-use client interface, quick online product set up, offers preparation in multiple languages and easy modification within minutes.

ClimaCAD is fully integrated with in-house IT systems and enables real time collaboration among multiple users all over the world.

- Easy to use AHU selection application (ClimaCAD On-line).
- Enter the selection application at www.vtsgroup.com
- Select the AHU you need in 60 seconds.





Quality First

The highest quality of VTS devices is appreciated by the leading World experts - including TUV, BVQI, Rostest, MBF-TMB.



UL 1995

UL 1995 - VENTUS Born in the USA AHUs meet a number of strict security requirements imposed on equipment in the US and Canadian market. The units were tested by independent ETL laboratory in terms of durability of the structure and safe use of equipment.



TUV

EN 1886 and EN 13053 are two European standards concerning Mechanical and Performance aspects of Air Handling Units. They are the only basis to apply for the membership in the EUROVENT Certification Company organization and obtain a EUROVENT certificate.

The research process is carried out by independent research institutions with CEN – European Committee for Standardization notification including TÜV among others.



CE

CE - VTS devices comply with safety standards in accordance with EU guidelines. VTS units have been tested in accordance with Low Voltage Directive, Electromagnetic Compatibility and Machinery Directive.



ISO

ISO 9001 / ISO 14001 – a system of quality management implemented in VTS in 1996 in the field of design guarantees full repeatability of all VTS devices. ISO 14001 certificate confirms the efficiency of the environment management system aimed at protection of health and the environment against the harmful influence of production activity, products and services.

Reliable Business Partner. Thousands of satisfied customers around the world are the best recommendation of VTS.





The products worth investing in



Get more **for less**
– maximum features in standard unit without added costs.

VTS Air Handling Unit – VENTUS Born in the USA combines European technology and American sustainability - it is tailored to the needs of the American market.

The compact air handlers are available in either horizontal (model VTS-h) or vertical (model VTS-v) configurations. Horizontal units are typically floor mounted, however they can be installed as a ceiling suspended unit.

Vertical units are typically floor mounted. The units can be configured for different inlet and outlet locations for easy duct connection and right or left hand configuration.

VTS compact air handlers offer a wide range of application and flexibility between the blower coil unit and the packaged units. Our VENTUS born in the USA line is available in nine nominal airflow sizes from 800 CFM up to 8,500 CFM, while the cooling capacities are available from 0.5 to 30 tons.

In addition, VTS units are made with a high durability polyurethane sandwich panels which minimize vibration, noise and eliminate thermal bridges compared with typical blower coils and air handling units. This significantly reduces the emission of acoustic power level through the casing, enabling to keep quiet operation of our AHUs. The innovative casing design also enables operation of our units in very different climate conditions, including cold Siberia or hot and humid Middle East, without risk of any internal or external condensation.

Units performance calculations has been tested and approved by Eurovent.

1 WEEK lead time as a STANDARD

Available in 9 nominal capacities
from 800 to 8500 CFM

Wide range of applications

- Operation in different climate conditions (-40°F to 150°F)
- Compact size – possibility of mounting in small spaces and easy relocation if needed



Filters

All units have internal or external flat filter frame for two or four-inch filters:

- Two-inch MERV8 filter
- Four-inch MERV13 filter

Control options

Coils

Main coil with copper tubes and aluminum fins in 1, 2, 3, 4, 6 and 8 rows hydronic and 2, 3, 4 and 6 row for DX

Innovative Frameless casing

Low vibration, noise and elimination of thermal bridges - high durability polyurethane sandwich panels.

PLENUM Fan

Composite backward-curved air foil fan impeller, directly driven by highly efficient electric motor.

Typical applications:

Schools

Offices

Stores

Hospitals

Industries

Capacity: 800 – 8,500 CFM



**Horizontal Air Handlers range
VTS 8 – VTS 85 Sizes:**

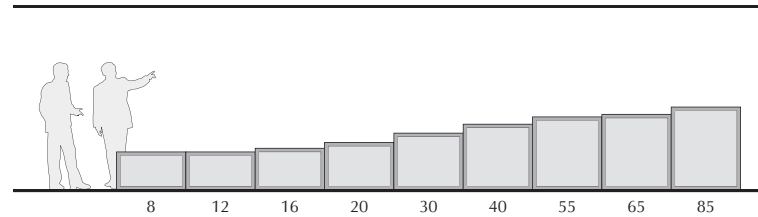

**Horizontal Air Handlers range with energy recovery
VTS 8 – VTS 85 Sizes:**

VTS 8 - VTS 85 Units with Cross Flow Plate
VTS 12 - VTS 65 Units with Energy Recovery Wheel

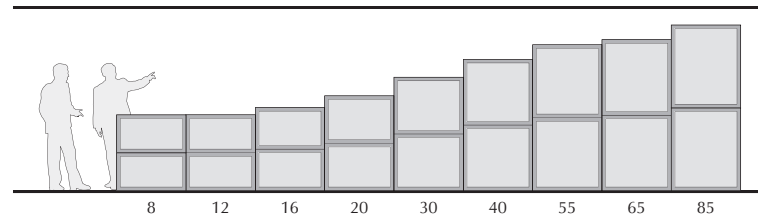

**Vertical Air Handlers range
VTS 8 – VTS 40 Sizes:**

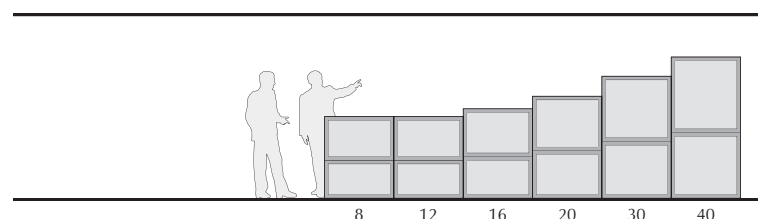

Symbols and labels

Basic functions of a base AHU

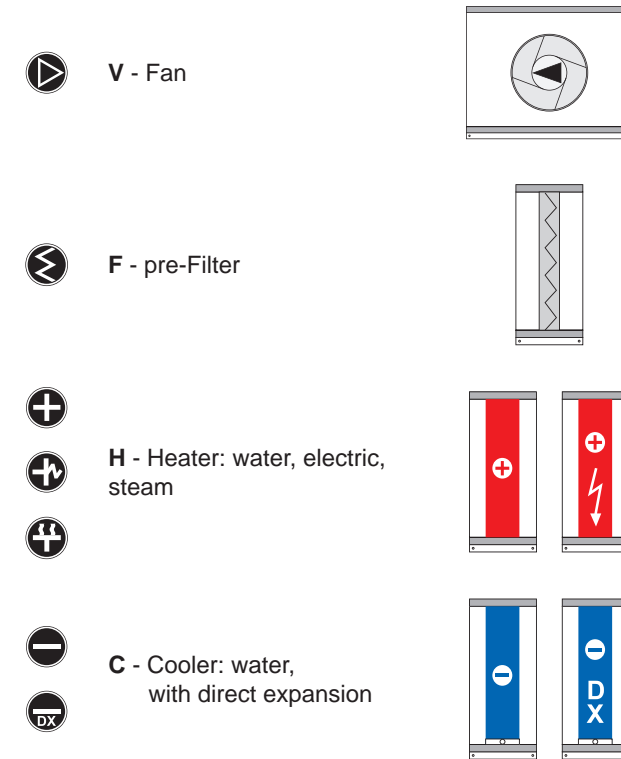

Energy recovery functions

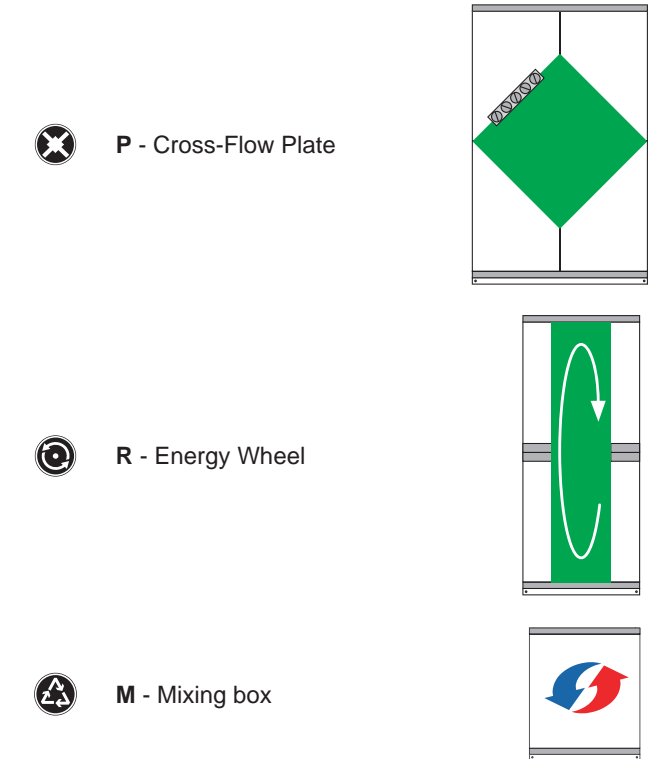

Main unit configuration

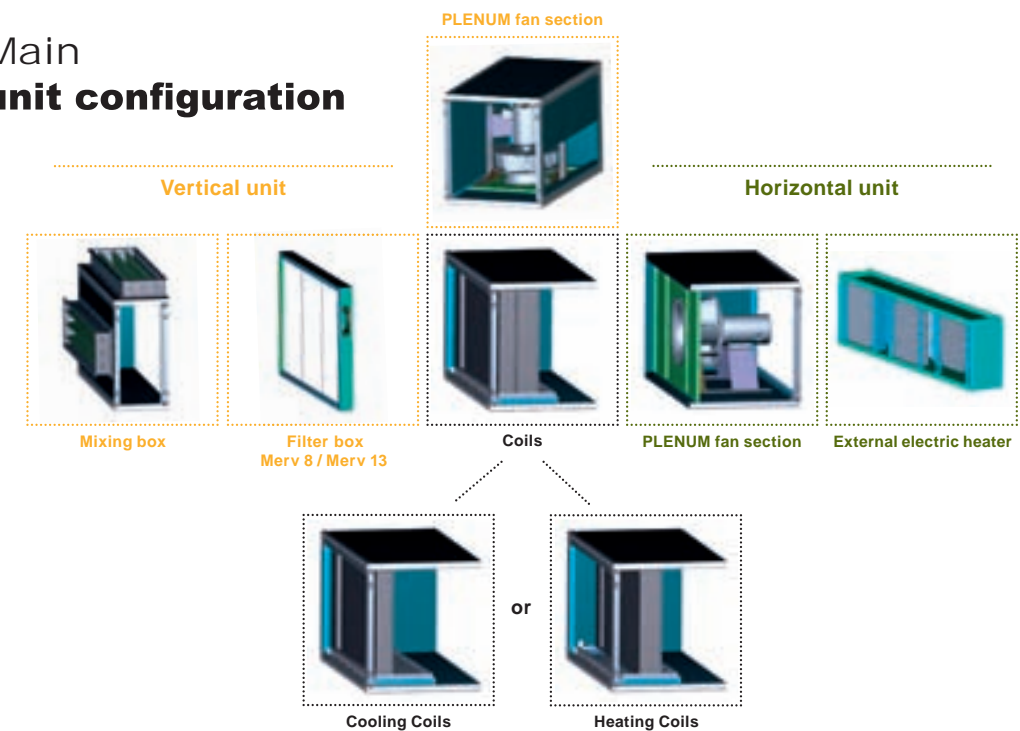

Configurations

VTS Horizontal Air Handlers

Supply	Heating				
	Cooling				
	Heating & Cooling				

Exhaust	Ventilation				
---------	-------------	--	--	--	--

Cross-flow plate	Ventilation				
	Heating				
	Cooling				
	Heating & Cooling				

Energy Wheel	Ventilation				
	Heating				
	Cooling				
	Heating & Cooling				

VTS Vertical Air Handlers

Supply	Heating				
	Cooling				
	Heating & Cooling				

Air intake, Air discharge configurations Horizontal Air Handlers

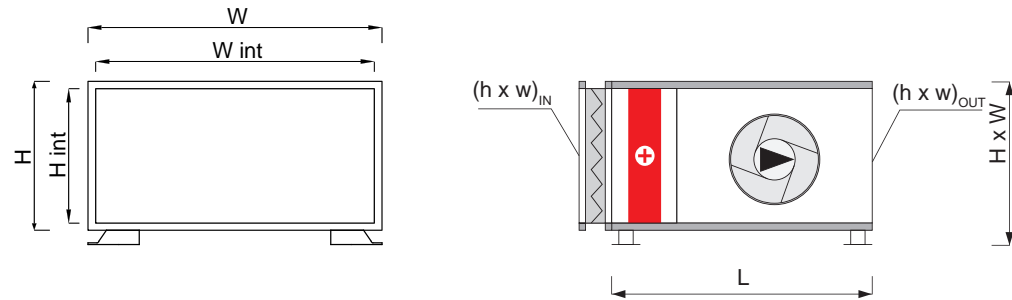

Unit Size	W	H	W int	H int	Base Unit L		h x w	
					min	max	in	out
	[in]	[in]	[in]	[in]	[in]	[in]	[in]	[in]
VTS - 8	27.2	20.8	24.0	14.5	36.2	44.3	20.9 x 11.3	20.8 x 11.3
VTS - 12	37.8	20.8	34.7	14.5	36.2	50.6	31.5 x 11.3	31.5 x 11.3
VTS - 16	43.4	22.8	40.3	16.5	36.2	50.6	37.1 x 13.3	37.1 x 13.3
VTS - 20	46.0	26.0	42.8	19.7	36.2	58.7	39.6 x 16.5	39.6 x 16.5
VTS - 30	52.7	31.1	49.6	25.0	44.3	65	46.4 x 21.8	46.4 x 21.8
VTS - 40	58.3	36.0	55.1	29.7	44.3	65	51.9 x 26.5	51.9 x 26.5
VTS - 55	65.4	40.0	62.2	33.7	44.3	65	59.0 x 30.5	59.0 x 30.5
VTS - 65	74.4	41.4	71.3	35.1	50.6	73.1	68.1 x 31.9	68.1 x 31.9
VTS - 85	82.1	45.4	78.9	39.1	50.6	73.1	75.7 x 35.9	75.7 x 35.9

Unit Size	Min. Airflow [CFM]	Nominal Airflow [CFM]	Max. Airflow [CFM]	1000 [CFM]	2000 [CFM]	3000 [CFM]	4000 [CFM]	5000 [CFM]	6000 [CFM]	7000 [CFM]	8000 [CFM]	9000 [CFM]	10 000 [CFM]
VTS - 8	334	800	838	Nominal									
VTS - 12	481	1200	1215										
VTS - 16	655	1600	1662										
VTS - 20	877	2000	2227										
VTS - 30	1237	3000	3232										
VTS - 40	1763	4000	4476										
VTS - 55	2305	5500	5854										
VTS - 65	3233	6500	7112										
VTS - 85	4477	8500	8822										

Legend:
W - unit width
H - unit height
W int - unit internal cross-section width
H int - unit internal cross-section height

L min: minimum unit length
L max: maximum unit length
h x w (in) - inlet height x width
h x w (out) - outlet height x width

Air intake, Air discharge configurations Vertical Air Handlers

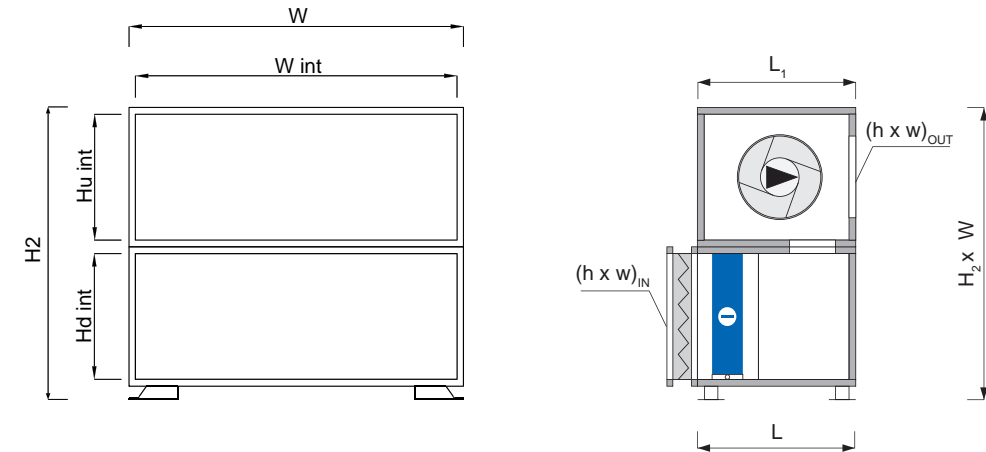

Unit Size	W	H2	W int	Hd int	Hu int	Base Unit L	h x w	
							in	out
	[in]	[in]	[in]	[in]	[in]	[in]	[in]	[in]
VTS - 8	27.2	43.6	24.0	14.5	19.7	29.9	20.8 x 11.3	20.8 x 16.5
VTS - 12	37.8	43.6	34.7	14.5	19.7	29.9	31.5 x 11.3	31.5 x 16.5
VTS - 16	43.4	45.7	40.3	16.5	19.7	29.9	37.1 x 13.3	37.1 x 16.5
VTS - 20	46.0	54.1	42.8	19.7	25.0	29.9	39.6 x 16.5	39.6 x 21.8
VTS - 30	52.7	59.4	49.6	25.0	25.0	29.9	46.4 x 21.8	46.4 x 21.8
VTS - 40	58.3	68.9	55.1	29.7	29.7	29.9	51.9 x 26.5	51.9 x 26.5

Unit Size	Min. Airflow [CFM]	Nominal Airflow [CFM]	Max. Airflow [CFM]	1000 [CFM]	2000 [CFM]	3000 [CFM]	4000 [CFM]	5000 [CFM]	6000 [CFM]	7000 [CFM]	8000 [CFM]	9000 [CFM]	10 000 [CFM]
VTS - 8	334	800	838	Nominal									
VTS - 12	481	1200	1215										
VTS - 16	655	1600	1662										
VTS - 20	877	2000	2227										
VTS - 30	1237	3000	3232										
VTS - 40	1763	4000	4476										

Legend:
W - unit width
H2 - unit height
W int - unit internal cross-section width
H int - unit internal cross-section height

L min: minimum unit length
L max: maximum unit length
h x w (in) - inlet height x width
h x w (out) - outlet height x width

Air intake, Air discharge configurations Energy Wheel Air Handlers

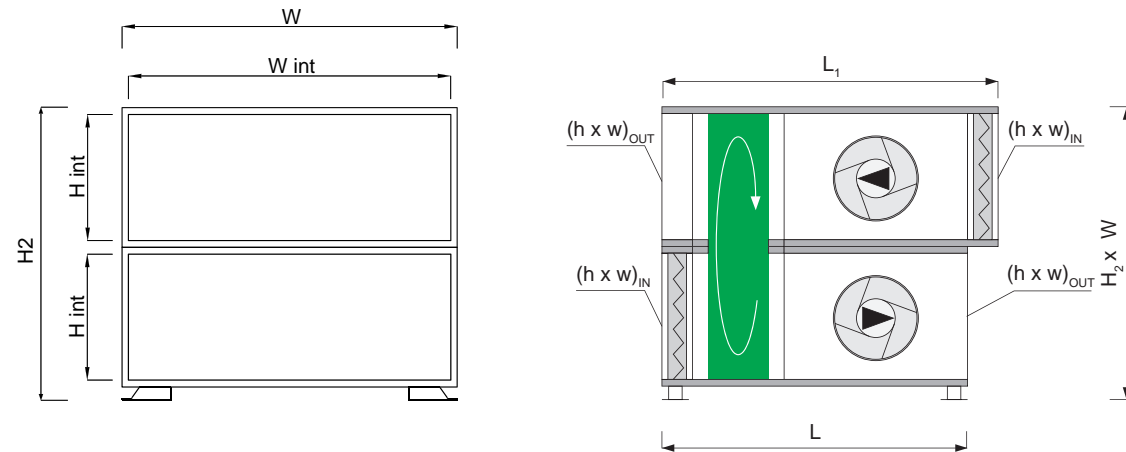

Unit Size	W	H2	W int	H int	Base Unit L		h x w	
					min	max	in	out
					[in]	[in]	[in]	[in]
VTS - 12	37.8	38.4	34.7	14.5	58.7	73.1	31.5 x 11.3	31.5 x 11.3
VTS - 16	43.4	42.5	40.3	16.5	65	73.1	37.1 x 13.3	37.1 x 13.3
VTS - 20	46.0	48.8	42.8	19.7	73.1	79.4	39.6 x 16.5	39.6 x 16.5
VTS - 30	52.7	59.4	49.6	25.0	73.1	79.4	46.4 x 21.8	46.4 x 21.8
VTS - 40	58.3	68.9	55.1	29.7	73.1	87.5	51.9 x 26.5	51.9 x 26.5
VTS - 55	65.4	76.8	62.2	33.7	79.4	87.5	59.0 x 30.5	59.0 x 30.5
VTS - 65	74.4	79.7	71.3	35.1	79.4	93.8	68.1 x 31.9	68.1 x 31.9

Unit Size	Min. Airflow [CFM]	Nominal Airflow [CFM]	Max. Airflow [CFM]	1000 [CFM]	2000 [CFM]	3000 [CFM]	4000 [CFM]	5000 [CFM]	6000 [CFM]	7000 [CFM]	8000 [CFM]	9000 [CFM]	10 000 [CFM]
VTS - 12	1008	1200	1215	Nominal									
VTS - 16	1008	1600	1662										
VTS - 20	1008	2000	2227										
VTS - 30	1356	3000	3232										
VTS - 40	1763	4000	4476										
VTS - 55	2305	5500	5854										
VTS - 65	3233	6500	7112										

Legend:
W - unit width
H2 - unit height
W int - unit internal cross-section width
H int - unit internal cross-section height

L min: minimum unit length
L max: maximum unit length
h x w (in) - inlet height x width
h x w (out) - outlet height x width

Air intake, Air discharge configurations Cross Plate Air Handlers

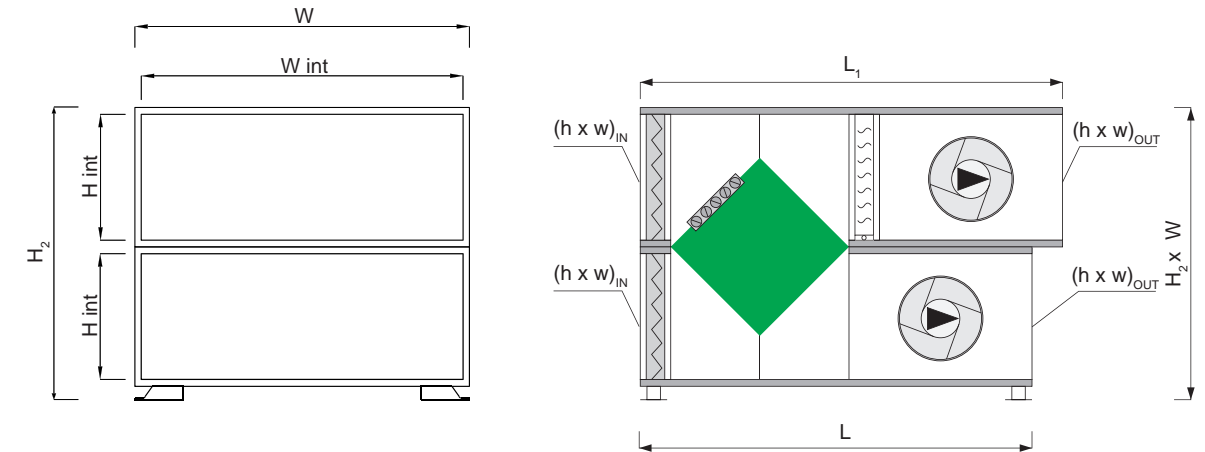

Unit Size	W	H2	W int	H int	Base Unit L		h x w	
					min	max	in	out
					[in]	[in]	[in]	[in]
VTS - 8	27.2	38.4	24.0	14.5	58.7	73.1	20.8 x 11.3	20.8 x 11.3
VTS - 12	37.8	38.4	34.7	14.5	58.7	73.1	31.5 x 11.3	31.5 x 11.3
VTS - 16	43.4	42.5	40.3	16.5	79.4	87.5	37.1 x 13.3	37.1 x 13.3
VTS - 20	46.0	48.8	42.8	19.7	87.5	93.8	39.6 x 16.5	39.6 x 16.5
VTS - 30	52.7	59.4	49.6	25.0	87.5	93.8	46.4 x 21.8	46.4 x 21.8
VTS - 40	58.3	68.9	55.1	29.7	101.9	116.3	51.9 x 26.5	51.9 x 26.5
VTS - 55	65.4	76.8	62.2	33.7	108.1	116.3	59.0 x 30.5	59.0 x 30.5
VTS - 65	74.4	79.7	71.3	35.1	108.1	122.6	68.1 x 31.9	68.1 x 31.9
VTS - 85	82.1	87.6	78.9	39.1	108.1	122.6	75.7 x 35.9	75.7 x 35.9

Unit Size	Min. Airflow [CFM]	Nominal Airflow [CFM]	Max. Airflow [CFM]	1000 [CFM]	2000 [CFM]	3000 [CFM]	4000 [CFM]	5000 [CFM]	6000 [CFM]	7000 [CFM]	8000 [CFM]	9000 [CFM]	10 000 [CFM]
VTS - 8	334	800	838	Nominal									
VTS - 12	481	1200	1215										
VTS - 16	766	1600	1662										
VTS - 20	959	2000	2227										
VTS - 30	1314	3000	3232										
VTS - 40	1838	4000	4476										
VTS - 55	2305	5500	5854										
VTS - 65	3233	6500	7112										
VTS - 85	4477	8500	8822										

Legend:
W - unit width
H2 - unit height
W int - unit internal cross-section width
H int - unit internal cross-section height

L min: minimum unit length
L max: maximum unit length
h x w (in) - inlet height x width
h x w (out) - outlet height x width

Functions

The Casing

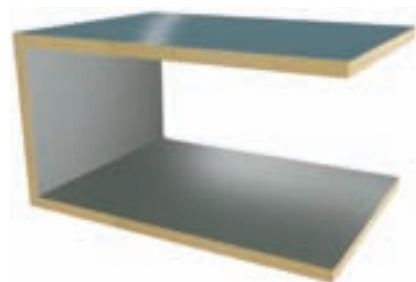

Function and Application

- Non-skeleton casing (structural components) constructed of a sandwich panel of polyurethane (1.6 inch thick) covered in both sides with a double side zinc coated 25 gauge steel sheet covered with an organic polyester coating,
- An excellent mechanical strength and resistance to the toughest ambient conditions.
- Energy loss reduction – no thermal bridges.
- Elimination of moisture condensation phenomenon.
- High rigidity of the construction.
- Fire resistant sandwich panel and odorless compound - thermal, vibration and acoustical insulation.
- Elements connected with sealed joints.
- Coil access panels can be located at the right or left side of the unit, and allow easy removal of the internal coils and drain pan, while the piping connections are located in the opposite side of the inspection panels.

Operation parameters

The VTS Air Handler's casing has the following ratings according to European EN 1886 Standard (EN 1886: 2007: Ventilation for buildings. Air handling units. Mechanical performance).

- Mechanical Strength (deflection)
-10 in WC to 10 in WC < 0.08 in
- Air leakage
-1.6 in WC: 0.009 CFM/ft²
+2.8 in WC: 0.026 CFM/ft²
- Thermal transmittance
U = 0.0969 BTU/hr * ft² * °F
- Thermal bridging
Kb = 0.69

Unit designed for both indoor and outdoor installation.

Panels:
Operation temperature: -40 ÷ +194°F.
Panel thickness: 1.6 inch.
Metal sheet thickness: 25 Gauge.
Thermal conductivity 0.0127 BTU/hr*ft*°F
Casing fire rating: non-flammable material (NRO)
Moisture absorption: 0.04%.
PPU density: 2.62 lb/ft³.
Panel linear weight: 2 lb/ft².
Color – RAL 7031.



Fan Construction

- Fan set based on single inlet, air foil backward curved radial impellers with 7 blades made of a polymer composite material to minimize the impeller weight and provide the best operating performance.
- Dynamically balanced.

Impeller sizes

VTS Unit Size	Impeller nominal size [in]
VTS - 8	8.9
VTS - 12	9.8
VTS - 16	12.4
VTS - 20	14
VTS - 30	15.7
VTS - 40	17.7
VTS - 55	19.7
VTS - 65	22.0
VTS - 85	22.0

Variable Frequency Drives



Function and application

VENTUS Born in the USA units have a Variable Frequency Drive (VFD) as a standard.

- Accurate selection of air flow design and external static pressure with a smooth regulation by proportional change of the motor-fan unit rotational speed.
- Protection of the maximal value of the motor current, the capability to be integrated with external analogue and binary signals and the integration to the BMS system.

Direct Driven Plenum Fans



Function and application

- Single inlet, backward-curved, directly driven centrifugal fan.
- Low and medium pressure ventilation and air conditioning systems, with total static pressure increase up to 8 InWG
- Impeller made of light composite material, suring low momentum of inertia (low level of start-up current on the motor) and minimized motor bearings load.

Design

- Beltless configuration and motor/fan pair placed on a common frame isolated from the unit structure by rubber vibration isolators.
- Variable frequency drive (VFD) as a standard.

Motor's specification

- All the units are built in belt-less drive motors configuration, with ranges from 0.75 to 10 HP in a wide range of voltages:
 - 1 Phase: 208 V and 230 V
 - 3 Phases: 208 V, 230 V and 460 V
- VTS offers two types of motors OPSB and TEFC, foot mounted and double shielded bearings.

Wiring Diagrams

Connection the mains supply with frequency converters.

Connection of 1ph frequency converters

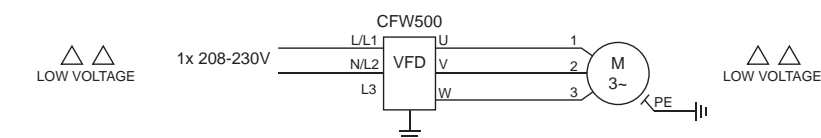
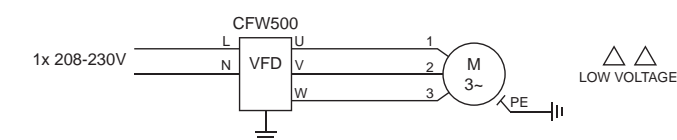
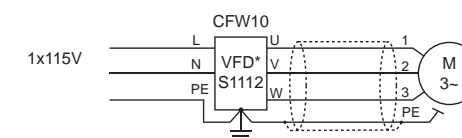

Functions

Connection of 3ph frequency converters

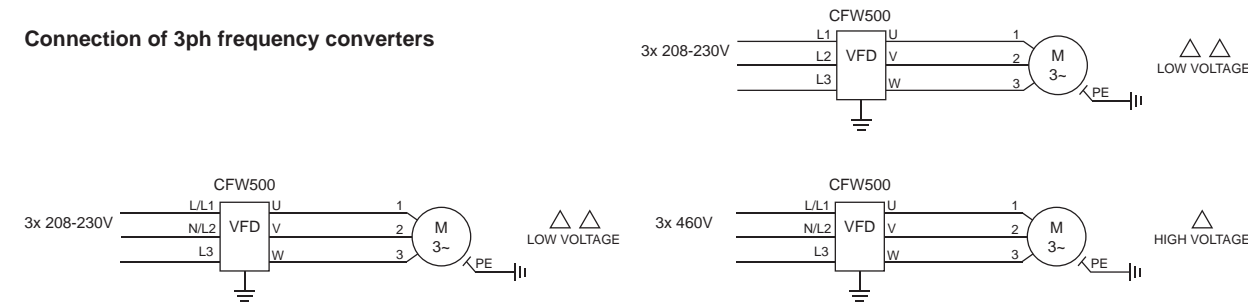

Filters

Function and Application

All units have a two or four inches flat pre-filter.

Vertical units

- External filter for the units without mixing box
- Internal filter for the units with mixing box.

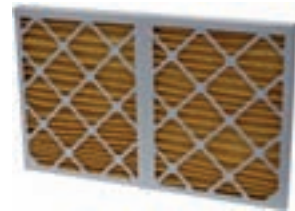

Horizontal units

- Optional internal or external filter for the units without mixing box.
- Internal filter for the units with mixing box.
- MERV8 2 inches filter.
 - 30-35% Dust Spot Efficiency.
 - > 90% Arrestance.
 - 3.0 – 10.0 pm Particle Size Typical Controlled Contaminant.
- MERV13 4 inches filter.
 - 89-90% Dust Spot Efficiency.
 - > 98% Arrestance.
 - 0.3 to 1.0 pm Particle Size Typical Controlled Contaminant.

Cooling Coils

Chilled Water Coils

Available in 3, 4, 6 and 8 rows with the following features:

Parameters

- Type: Cu-Al: Copper pipes, Aluminium fins
- Fin spacing: 10 fins per Inch
- Tube spacing: 1 ¼ In
- Tube diameter: ½ In
- Max operating pressure: 246 PSI (Tested at 493 PSI)
- Max glycol content: 50%



Direct Expansion (DX) Coils

Available in 2, 3, 4 and 6 rows with the following features:

Parameters

- Type: Cu-Al: Copper pipes, Aluminium fins
- Fin spacing: 10 fins per Inch
- Tube spacing: 1 ¼ In
- Tube diameter: ½ In
- Max operating pressure: 246 PSI (tested at 304 PSI)
- Max refrigerant temp: 82° F

Hot Water Heating Coil

The hot water coils are available in 1, 2, 3 and 4 rows with the following features:

- Type: Cu-Al: Copper pipes, Aluminium fins
- Fin spacing: 10 fins per Inch
- Tube wall thickness: 0,015 In
- Tube spacing: 1 ¼ In
- Tube diameter: ½ In
- Max water temperature: 200° F
- Max operating pressure: 246 PSI (Tested at 493 PSI)
- Max glycol content: 50%



Electric heaters

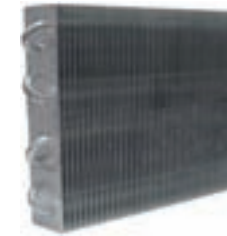

Function and Application:

- Made of insulated heating wire assembled inside the tubes with metal fins.
- Air temperature range: from -22° F to 86° F
- Maximum air leaving the electric heater of 104° F.

Design

- Square fin heating element made of insulated Nichrome heating wire, assembled inside the tubes with metallic fins.
- Nominal power in each heating circuit: 3 kW
- Up to 4 stages of heat
- Power supply to the electric heater through a factory mounted terminal block; a separate point power has been designed for the electric heater power connection.

Steam Coil

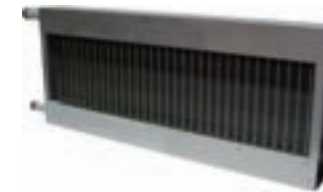

The steam coils are available in 1 row with the following features:

- Type: Cu-Al: Copper pipes, Aluminium fins
- Fin spacing: 10 fins per Inch
- Tube wall thickness: 0,015 In
- Tube spacing: 1 ¼ In
- Tube diameter: ½ In
- Max operating temperature: 400° F
- Max operating pressure: 72 PSI (Tested at 290 PSI)

Energy recovery systems

Cross-Flow Plate

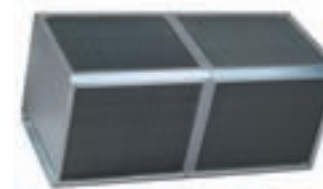

Function and Application

- Cross-Flow plates are an indirect energy recovery (sensible heat) accumulated in the stream of exhaust air and its transfer to the ventilation air supplied to the rooms.
- Heat recovery at very high separation of the stream of supply and exhaust air (99.9%).
- Application in block supply-exhaust AHUs.

Design

- A system of crosswise formed 9 to 4 gauge aluminium plates, between which separated streams of supply and exhaust air flow in an alternating crosswise pattern.
- Internal by-pass duct with installed air damper which allows to divert air flow outside the exchanger "window":

- Disabling energy recovery function. Function of the exchanger's anti-freeze protection
- Drop eliminator with a drain pan.

Operational Parameters

- Efficiency up to 75% (depends on the temperature difference between the air streams, moisture and ration of air streams) – Exchanger class B acc. EN 13053
- Exchanger tightness for nominal operation parameters: 99.9%
- Max. permissible air flow speed: 748 FPM.
- Recommended max. pressure drop: 1.8 in WC
- Max. difference between air flow pressures of supply and exhaust air: 6 in WC
- Ambient temperature: -40° F to 176° F

Compliance with standards: EN 308, EN 13053.

Functions

Energy Wheel



Function and application:

- Indirect energy recovery (sensible heat) accumulated in the exhaust air flow and its transfer to the counter current supply air flow.
- Indirect recovery of latent heat (moisture) when the rotor surface temperature on the side of the exhaust air is lower than the supply air dew-point temperature.
- Energy recovery without total separation of the supply and exhaust air flows (air leakages of 2 to 5 %).
- Application in block supply-exhaust AHUs.

Design

- The rotor which is 7.9 in thick, is installed on a shaft with bearing and built in a steel construction frame.
- Rotor filling: a spiral built on two alternating layers of flat and corrugated aluminum sheets of 13 gauge creating ducts of hydraulic diameter $D = 0.06$ in.

- Variable rotary speed drive system enabling max. exchanger efficiency and regulation of energy recovery level.
- Purge sector reducing the penetration of "dirty" exhaust air into the supply air to the minimum
- Brush seals placed on the rotor's perimeter and in the dividing line providing additional protection against air leakage.

Operational Parameters

- Efficiency up to 85% (depends on the temperature differences between the air streams, moisture and ratio of air flows) – exchanger class A acc. EN 13053
- Exchanger tightness for nominal operation parameters: 95%
- Max. permissible air flow speed: 1,000 FPM
- Rotor rotational speed: 10 RPM
- Recommended max. pressure drop: 1.8 in WC.
- Ambient temperature: -30 °F to 158°F

Mixing Box



Function and Application:

- Direct energy recovery (sensible and latent heat) as result of mixing two streams of air – the outside with the exhaust air.
- AHU operation in fast heating mode for units equipped with an "internal" mixing box.
- In case of high concentration of toxic substances in a room using recirculation is forbidden.
- The recirculation function constitutes an optional element of a unit's equipment.

Design

- Mixing box is equipped with an appropriate double system of inlets/outlets armed with dampers to regulate the proportional share of the outside air to the exhaust (return) air.

Operation parameters

- Efficiency up to 90% - Exchanger class A acc. EN 13053
- Operational temperature: -40° F to 158 F°

Horizontal units - lengths

Unit Size	Base Unit L	Base Unit L	With Mixing Box L	With Mixing Box L
	min	max	min	max
	[in]	[in]	[in]	[in]
VTS - 8	36.2	44.3	50.6	65.0
VTS - 12	36.2	50.6	50.6	65.0
VTS - 16	36.2	50.6	50.6	65.0
VTS - 20	36.2	58.7	58.7	73.1
VTS - 30	44.3	65	58.7	79.4
VTS - 40	44.3	65	65.0	79.4
VTS - 55	44.3	65	73.1	101.9
VTS - 65	50.6	73.1	87.5	101.9
VTS - 85	50.6	73.1	87.5	101.9

Vertical units - lengths

Unit Size	Base Unit L	With Mixing Box L
	[in]	[in]
VTS - 8	29.9	50.6
VTS - 12	29.9	50.6
VTS - 16	29.9	50.6
VTS - 20	29.9	58.7
VTS - 30	29.9	58.7
VTS - 40	29.9	58.7

Mixing Box inlet/outlet configurations

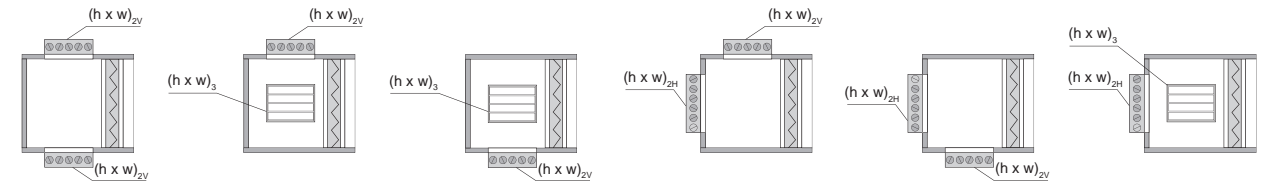

Horizontal Units - dimensions of inlet/outlet

Unit Size	(h x w) _{2H}	(h x w) _{2V}	(h x w) ₃
VTS - 8	8.0 x 18.0	8.0 x 18.0	8.0 x 11.0
VTS - 12	8.0 x 26.0	8.0 x 26.0	8.0 x 11.0
VTS - 16	8.0 x 34.0	8.0 x 34.0	8.0 x 13.0
VTS - 20	12.0 x 26.0	12.0 x 26.0	12.0 x 16.0
VTS - 30	12.0 x 34.0	12.0 x 34.0	12.0 x 21.0
VTS - 40	12.0 x 48.0	12.0 x 48.0	12.0 x 21.0
VTS - 55	16.0 x 48.0	16.0 x 48.0	16.0 x 30.0
VTS - 65	16.0 x 60.0	16.0 x 60.0	16.0 x 30.0
VTS - 85	20.0 x 60.0	20.0 x 60.0	20.0 x 35.0

Vertical Units - dimensions of inlet/outlet

Unit Size	(h x w) _{2H}	(h x w) _{2V}	(h x w) ₃
VTS - 8	8.0 x 18.0	8.0 x 18.0	8.0 x 11.0
VTS - 12	8.0 x 26.0	8.0 x 26.0	8.0 x 11.0
VTS - 16	8.0 x 34.0	8.0 x 34.0	8.0 x 13.0
VTS - 20	12.0 x 26.0	12.0 x 26.0	12.0 x 16.0
VTS - 30	12.0 x 34.0	12.0 x 34.0	12.0 x 21.0
VTS - 40	12.0 x 48.0	12.0 x 48.0	12.0 x 21.0

Horizontal Units - Mixing Box Openings

Unit Size	A	A1	B	B1	B2	C	C1
	[in]	[in]	[in]	[in]	[in]	[in]	[in]
VTS - 8	18.0	4.6	8.0	4.8	10.9	11.0	3.3
VTS - 12	26.0	5.9	8.0	4.8	10.9	11.0	3.3
VTS - 16	34.0	4.7	8.0	5.8	10.9	13.0	3.3
VTS - 20	26.0	10.0	12.0	5.4	8.9	16.0	3.4
VTS - 30	34.0	9.4	12.0	8.1	8.9	21.0	3.6
VTS - 40	48.0	5.1	12.0	10.4	8.9	21.0	5.9
VTS - 55	48.0	8.7	16.0	10.4	8.9	30.0	3.4
VTS - 65	60.0	7.2	16.0	11.1	8.9	30.0	4.1
VTS - 85	60.0	11.0	20.0	11.1	8.9	35.0	3.6

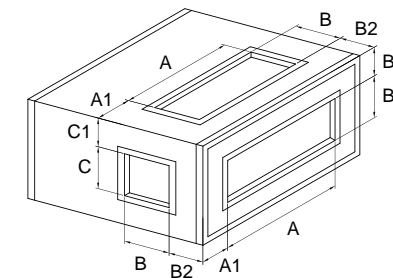

Vertical Units - Mixing Box Openings

Unit Size	A	A1	B	B1	B2	C	C1
	[in]	[in]	[in]	[in]	[in]	[in]	[in]
VTS - 8	18.0	4.6	8.0	4.5	10.9	11.0	9.4
VTS - 12	26.0	5.9	8.0	4.5	10.9	11.0	9.4
VTS - 16	34.0	4.7	8.0	5.0	10.9	13.0	9.4
VTS - 20	26.0	10.0	12.0	5.0	8.9	16.0	9.4
VTS - 30	34.0	9.4	12.0	5.0	8.9	21.0	9.4
VTS - 40	48.0	5.1	12.0	5.0	8.9	21.0	9.4

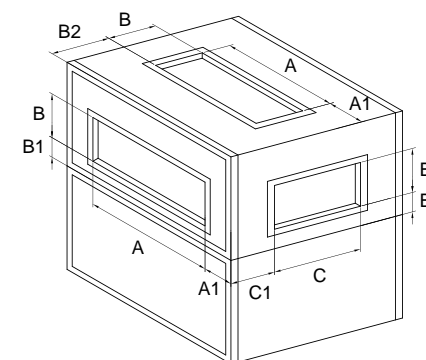



Variable Frequency Drives



Controls

HMI User

- Regulation of AHU's basic parameters



HMI Service

- Advanced management over all AHU's operational parameters



Duct temperature sensor

- Air Temperatures monitoring
- Monitoring of AHU Start and Stop sequence

Differential pressure switch

- Filter contamination monitoring
- Alarm triggering when air pressure drop threshold is exceeded

0-10 V air damper actuator

- Air dampers positioni regulation
- Economizer performance control
- Cross-plate anti-freeze protection

Low limit Thermostat

- Control of minimal air temperature downstream the heating coil.
- Changing the AHU operational mode into ALERT, in case of heater overcooling

Three-way valve with electric actuator

- Hydronic coils performance regulation

Control applications

HMI User	26
HMI Service	27
Duct temperature sensor	28
Low limit Thermostat	28
Room temperature sensor	28
Variable Frequency Drives	29
Overheat protection thermostat	29
0-10 V air damper actuator	30
Three-way valve with electric actuator	30
Differential pressure switch	31
VS UPC controller for air supply, exhaust and supply-exhaust units	31
Supply AHUs	33
Supply-exhaust AHUs: cross-flow exchanger	36
Supply-exhaust AHUs: rotary exchanger	38

VENTUS Born In The USA air handling units are not only devices, they also feature systems carefully selected and programmed control applications enabling professional management of air ventilation and conditioning systems.

VTS uses control algorithms that have been developed with energy savings philosophy, while at the same time maintaining the required parameters of the air supplied and ensuring reliability of our units.

For management of our **VENTUS Born In The USA** air handling units we recommend our control application based on CAREL UPC controller, supporting all advanced control functions, variable ways of external communication including integration with Building Management Systems

Control Applications Control Elements

HMI User



Function and Application

- Zone temperature measurement.
- Setting and reading of basic operating parameters of ventilation or air conditioning units:
 - air parameters;
 - efficiency change;
 - operation mode change;
 - breakdown states.
- Independent Calendar.
- Knob default function – air temperature setting.

Design

- Electronic circuit with thermistor measuring element (NTC) installed in a plastic housing.
- LCD display.
- Operating panel.
- Knob facilitating setting of parameters.

LCD Display

Indicates actual room temperature or temperature on the main control sensor as well as a chosen setting, operation mode, fan speed, time and day of the week.

ON/OFF button

Switching between On/Off state (forcing the unit to stop or enabling operating mode selection)

Fan button

Mode setting: Auto / Low / Econo / Comfort

Clock button

Entering Auto mode. Controller will operate according to the time schedule stored in Calendar settings.

NOTICE! There are two options for time schedule operation. For details, follow chapters related to Calendar and to Service Menu.

NOTICE! If the Calendar is also in Auto mode, the AHU operation will rely only on protective and energy saving functions like Standby and Night Cooling. This is possible for the main Calendar of the controller. The built-in Calendar of the HMI Basic doesn't support that functionality

Push & Roll knob

Quick, intuitive and easy entering values, changing setpoints, accepting new values

- Display of the room sensor temperature or the value of the temperature setpoint
Note! Setting is limited to 60.8.. 78.8 oF (16..26°C) Icons for active recirculation, cooling or heating
- Time indication.
- Display of the fan speed setting or the indication of automatic fan mode
- Indications of the weekdays
- Icon for active recovery unit

- Icon for alarm event
- Icon for Off mode

CALENDAR MODE IN HMI USER

HMI Basic can operate with time schedules in two ways. Selection is done in Service Menu of the µPC controller and is available only via HMI Advanced interface.

- HMI User can use the calendar in the controller – all settings are done via HMI Advanced or via BMS connection and HMI User can only activate / deactivate operation according to time schedule stored in the controller.
NOTICE! HMI User cannot change any settings in the controller's calendar.
- HMI Basic can use own local time scheduler – all the settings are done and stored in HMI User.
NOTICE! Mind the limitations of the HMI's calendar – only On/Off and temperature settings can be adjusted in the HMI User. Low / Econo / Comfort modes must be pre-set in the controller settings via HMI Service.

Setting the program for selected days:

1. Clock button - long-press to enter settings mode.
2. Turn the knob to select "Time band" and press to enter.
3. In "Sel days" turn the knob to select days - whole week, working days, weekend, or any day separately. Then press to enter.
4. Observe the house icon - it indicates which time zone is edited at the moment. Turn the knob to select specific time zone from 1 to 6. Press to enter.

Operation parameters

- Power supply
Directly from the control cabinet
~24 VAC (-15..+10%) or 22..35 VDC
- Temperature measurement: 32 ÷ 1040 °F
- Measurement accuracy: ±0.9 F
- Communication with the controller via Modbus RTU protocol
- Communication cable length: max. 1,500 ft
- Protection class: NEMA 2
- Ambient temperature: 14 ÷ +140 °F / RH<90%, without condensation

5. Turn the knob to set hour and press to confirm.
NOTICE! Between 23 and 00 there's blank setting --:-- which means, that current time zone is skipped.
6. Turn the knob to set minutes and press to confirm.
7. Turn the knob to set the temperature and press to confirm.
NOTICE! Below minimum setpoint there's OFF setting. Use that to turn off the unit in selected time zone.
8. To leave from any level of calendar programming, select ESC and press to confirm. To set clock, long-press the Clock button to enter settings mode, turn the knob to select Clock, press to enter and set proper hour, minutes and weekday.
NOTICE! Setting the weekday properly is necessary for correct operation of the Calendar mode.

WEB-SERVER OPTION (TCP/IP Modbus)

Gives extended access to read / write parameters like measurement readouts, setpoints, settings, output values, selected calendar settings, alarms. Total count of available parameters exceeds 200 datapoints.



HMI Service



Function and Application

- Setting and reading of advanced operating parameters of ventilation or air conditioning units.
- Frequency converters remote programming .
- Management and cancelation of units operational errors is done by full text description.
- Management of the controller main Calendar.
- Configuration of the controller universal inputs and outputs.

Design

- Electronic circuit installed inside a plastic housing.
- Legible textual LCD display.
- Communication cable (3 ft as standard) for the controller connection with the RJ 11 connector.

Operation parameters

- Power supply: directly from the UPC controller
- Communication port: serial port, RS485 standard
- Communication cable length: max. 3,600 ft
- Connection method: 1:1
- Protection class: NEMA 2
- Ambient temperature: -4 ÷ +140°F / φ<85%, without condensation

NAVIGATION

LCD Display

Displaying available parameters, settings and current values.

BELL Button

Jump to alarm handling pages.

PRG Button

1. Quick jump to the Calendar main page
2. In Calendar pages - quick clear of the settings.

ESC Button

Jump to the main page or leaving the parameter change.

UP Arrow

1. Moving up across the menu screens (when the cursor stays in upper left corner).
2. Increasing the parameter value.

ENTER Button

1. Moving the cursor across the screen - cursor jumps to the next parameter available for changing. Read-Only parameters are not marked with the cursor.
2. Confirming entered values.
3. Entering sub-menus from the main menu level:
 - Parameters
 - Calendar
 - Alarms
 - Settings
 - Service

DOWN Arrow

1. Moving down across the menu screens (when the cursor stays in upper left corner).
2. Decreasing the parameter value.

Navigation's example:

1. In the main menu level use UP/DOWN arrows to find the desired sub-menu.
2. Press ENTER to go to the sub-menu level.
3. Use UP/DOWN arrows to move across the sub-menu screens.
4. In the desired screen, use the ENTER button to switch between the changeable parameters - the cursor starts from the upper left corner (which is the base position) and jumps on and on until going back to the upper left corner - then the loop can be started again.
5. To change the parameter marked with the cursor, use the UP/DOWN arrows.
6. Press ENTER to go confirm the change and to jump further.

Parameters available in the LCD window depends on a AHU type and the control application. Hence in AHUs not equipped with heater, options related to the heating module will not be visible. HMI Service UPC can't serve as a room temperature sensor. HMI Service is an optional element.

MAIN MENU FUNCTIONS

1. Main default screen with most important statuses and setpoints.
 - **Set mode HMI** – is used to set the main operating mode from the HMI.
 - **Current mode** – indicates current AHU mode resulting from HMI setting, alarms, external control signals etc.

- **Set temp HMI** – is used to enter the main temperature setpoint from the HMI.
 - **Current temp** – temperature readout from the main sensor.
2. Second main status screen
 - Fans – indicates the current state and rate of the fans.
 - Dampers – indicates the current state and opening rate of the dampers.
 - Regulator – indicates the state and the output of the main controller for heating / cooling function.
 - Recovery – indicates the state and rate of the heat recovery unit.
 - EN/PL/RU – language selection.
 - PASSWORD – is used to enter to special settings and hidden parameters.
 3. Sub-menu link screen.
 - **PARAMETERS** ⇒ link to main statuses and readouts from the control system.
 4. Sub-menu link screen.
 - **CALENDAR** ⇒ link to calendar settings and time schedule programming .
 5. Sub-menu link screen.
 - **ALARMS** ⇒ link to alarm pages.
 6. Sub-menu link screen.
 - **SETTINGS** ⇒ link to set and adjust the control system, regulators, timers.
 7. Sub-menu link screen.
 - **SERVICE MENU** ⇒ link to main configuration parameters, application codes, AHU startup settings.

Control Applications Control Elements

Duct temperature sensor



Function and Application

- Measurement of the temperature of supply, exhaust and outside air
- Securing max. and min. temperature of supply air.
- Protection against frost on the energy recovery unit via the temperature measurement of air exhausted upstream the energy recovery unit.

Design

- Resistance measuring element installed in an aluminum bayonet probe of 9.8 inches long.
- **The connection between the sensor and control cabinet is made with a shielded cable.**

Operation parameters

- Measurement range: $-58 \div +194$ °F
- Air humidity: $5 \div 100$ %
- Measurement Accuracy: $\pm 0.5K$
- Measuring element: NTC 10k
- Output signal: resistance
- Cables length: max. 300 ft
- Protection class: NEMA 6

Low limit Thermostat



Function and Application

- When the air temperature drops below the minimum allowable temperature, signal from the thermostat stops AHU fans, closes external air dampers and adjusts control valve of the heater to the max. flow of heating medium.
- Switching into permanent alarm condition if the AHU protection is triggered three times within an hour.

Design

- Measuring element: Capillary pipe filled with refrigerant.
- The thermostat is equipped with adjusting screws which enable setting the minimum allowable operating temperature as well as the temperature of system reactivation (hysteresis).
- Housing: plastic.

Operation parameters

- Measurement range: $-0.4 \div +59$ °F
- Default switching threshold setting: 41 °F
- Hysteresis: $1.7 \div 12K$
- Rated operating voltage: 30 V DC, 230 V AC
- Output signal: potential-free (switchover contact)
- Protection class: NEMA 3

- **If the thermostat is used as anti-frost protection of the water heater, the capillary should be installed in the lowest temperature zone of the medium flowing into the heat.**

Room temperature sensor



Function and Application

- Room temperature measurement.

Design

- Resistance measuring element fitted on a PCB installed inside a plastic housing.

Operation parameters

- Measurement range: $-4 \div +158$ °F
- Air humidity: $5 \div 95$ % without condensation
- Measurement accuracy: $\pm 0.5K$
- Measuring element: NTC 10k (UPC)
- Output signal: resistance
- Cables length: max. 300 ft
- Protection class: NEMA 1

- **The connection between the sensor and control box is made with a shielded cable.**

Variable Frequency Drives



Function and Application

- Smooth regulation of the AHU air flow by proportional change of the motor-fan unit rotational speed.
- Maintaining fixed AHU operating parameters at varying air flow resistance of the ductworks.

Protection of maximal value of motor current.
Controlling of fan start-up with simultaneous protection of maximal value of start-up current.
Integration with external analog and binary signals.
Displaying and modification of fan-set working parameters.

Design

- The electronic circuit enabling motor voltage frequency adjustment and maintaining optimal U/f ratio.
- The circuit is installed inside a plastic housing.
- The fan ensuring cooling of the converter internal circuits.
- The operating panel allowing entering the frequency converter parameters.

- **The parameters are specific for a frequency convertor models that were selected as an examples.**
- **The frequency convertor types and models to be used in AHUs, each time have to be confirmed with VTS Sales Representative.**
- **The frequency convertors comply to EMC Directive 89/336/EEC (RFI filters for the Second Environment are not required).**

Operation parameters

- Supply Frequency: 50/60 Hz (48 Hz to 62 Hz)
- Control
 - Method: Type of control: V/f (Scalar); VVW: Voltage vector control; PWM SVM (Space Vector Modulation).
 - Output Frequency: 0 to 500 Hz, resolution of 0.015 Hz
- Analog Inputs:
 - 1 insulated input. Levels: (0 to 10) V or (0 to 20) mA or (4 to 20) mA.
 - Programmable functions.
- Digital Inputs:
 - 4 insulated inputs.
 - Programmable functions:
 - Active high (PNP)
 - Active low (NPN)
- Analog Output
 - 1 insulated output. Level (0 to 10) V or (0 to 20) mA or (4 to 20) mA.
 - Programmable functions
- Relay Output
 - 1 relay with NA/NF contact.
 - Maximum voltage: 240 Vac
 - Maximum current 0,5 A.
 - Programmable functions
- Communication Interface RS 485
 - Insulated RS485.
 - Modbus-RTU protocol with maximum communication of 38.4kbps.
- Enclosure
 - NEMA1/IP20

Overheat protection thermostat



Function and Application

- Over-heating protection for electric heater – switching off the heater and automatic reactivation once the temperature is lowered by the hysteresis value

Design

- Bimetallic element installed inside a metal housing.

Operation parameters

- Overheating setpoint temperature: 65 °F
- Re-switch On setpoint temperature: 113 °F
- Output signal: potential-free (switchover contact)
- Rated operating voltage: 20 V DC, 230 V AC

0-10 V air damper actuator



Function and Application

- Mixing ratio control for outdoor and room-exhausted air (economizer): 0-10 V actuator.
- Control of bypass air damper opening level for the Plate Cross-Flow – anti-frost protection of the energy recovery system:
- 0-10 V actuator.
 - Actuator with spring return:
 - economizer fresh air side
- Actuator with no spring return:
 - economizer return air side
 - by-pass damper for cross-plate based energy recovery system

Design

- Mechanical system with an electric motor installed inside housing.
- Actuator fitted for installation with a square-section stem 0.39±0.62 in or a round-section stem Ø 0.39±0.78 in.
- For air handling units equipped with water heater, the air damper actuator is additionally equipped with a return spring
 - air damper is closed when no supply voltage is present.

Operation parameters

- Regulation method: smooth 0-100%
- Supply voltage: 24 V AC
- Input signal: 0 - 10 V DC
- Rated torque: 88 in-lbs
- Rotation angle 90°
- Full opening time: 0 10 V: 80±90s; spring-forced return: 10s
- Number of cycles: 60 000
- Max. air damper area: 43 ft²
- Protection class: NEMA 3
- Ambient temperature: -4 ÷ +122 °F

Three-way valve with electric actuator



Function and Application

- Temperature adjustment of the medium flowing through the hydraulic coil .
 - Quality hydronic heater capacity regulation (system based on additional recirculation pump).
 - Quantity hydronic cooler capacity regulation.

Design

- **Actuator**
 - Mechanical system with an electric motor installed inside composite housing enables smooth adjustment of the valve opening
- **Valve**
 - Body: brass / steel
 - The valve regulation element: Ball / head
 - Material of the valve regulation element: stainless steel
- **For quality hydronic heater regulation, system must be aided with pump securing required rate of medium flow through the coil. Pump is not part of VTS control application delivery.**

Operation parameters

- **Actuator:**
 - Adjustment range: 0 - 100%
 - Supply voltage: 24 V AC/DC
 - Input signal: 0-10 V DC
 - Rated torque: 5-20Nm for kvs=44±177 in-lbs
 - Nominal pressure: 1800 N for kvs=100
 - Rotation angle: 90°
 - Protection class: NEMA 3
 - Ambient temperature: -4 ÷ +122 °F
- **Valve:**
 - Operating characteristics: Equal percentage/proportional Cv: 3 / 4.7 / 7.4 / 19 / 29 / 46 / 68 / 91
 - Pressure drop
 - Δ pmax = 200 kPa kvs ≤ 29 PSI
 - Δ pmax = 240 kPa kvs > 34 PSI
 - Medium temperature:
 - Cv= 3÷68: 14 ÷ 248°F
 - Cv = 91: 41 ÷ 248 oF
 - Maximum glycol content in the medium:
 - 50%
 - Ambient temperature: -4 ÷ +122°F

Differential pressure switch



Function and Application

- Monitoring the filter contamination in the Air Handling Unit by measuring the difference of static pressure before and after the filter.
- Control of the operation of a direct driven fan unit in case of cooperation with electric heater

Design

- Membrane coupled with the mechanical system deforms when a set acceptable pressure difference is exceeded, and, as a result, switches electrical contacts (filter contamination signal or fan unit operation)
- Housing material: ABS.

Operation parameters

- Measurement: 0,12÷1,20 in WG – filters of class MERV 6÷15
- Rated operating voltage: 250V AC (Imax=3A)
- Output signal: potential-free contact, NO or NC according to the application
- Switching capacity: 1min of cycles (at temp. of 140 °F)
- Protection class: NEMA 3
- Ambient temperature: -4 °F ÷ +140 °F

VS UPC controller for air supply, exhaust and supply-exhaust units



Function and Application

- Ventilation or air condition unit operating parameters adjustment, control and protection - operation, temperature, air flow and fault conditions.
- The AHU operation according to the Calendar with a possibility of a division into a time "zones".
- Remote management of the unit operation by means of external communication modules - HMI Basic or HMI Advanced user interfaces.
- Integration with an external modules in the scope of:

- start signal;
- fire protection signal;
- START/STOP circuit

Design

- Set of fuse-switches on the power supply circuit of the frequency converters
- Controller
- Mains switch
- PC (polycarbonate) housing with dimensions: 17.7 x 25.2 x 6.7 in

AP - control system application for air supply-exhaust units with cross-flow heat exchanger

Application code	Functions available in particular applications					
	HW	CW	DX	PRC. BPS	MIX. CMBR	SUM.ER
AP 32						
AP 33						
AP 36						
AP 37						
AP 40						
AP 41						
AP 160						
AP 161						
AP 164						
AP 165						
AP 168						
AP 169						

AR - control system application for air supply-exhaust units with thermal wheel

Application code	Functions available in particular applications					
	HW	CW	DX	PRC. BPS	MIX. CMBR	SUM.ER
AR 0						
AR 1						
AR 4						
AR 5						
AR 8						
AR 9						
AR 128						
AR 129						
AR 132						
AR 133						
AR 136						
AR 137						

AS - control system application for air supply units

Application code	Functions available in particular applications					
	HW	CW	DX	PRC. BPS	MIX. CMBR	SUM.ER
AS 1						
AS 4						
AS 5						
AS 8						
AS 9						
AS 65						
AS 68						
AS 69						
AS 72						
AS 73						
AS 193						
AS 196						
AS 197						
AS 200						
AS 201						

Symbols:
HW - Hydronic Water Coil
CW - Hydronic Coolig Coil
DX - Direct Expansion Cooling Coil

PRC.BPS - Cross-plate by-pass function
MIX.BOX - Cross Air Mixing Box, economizer
SUMM.ER - Energy recovery for summer operations

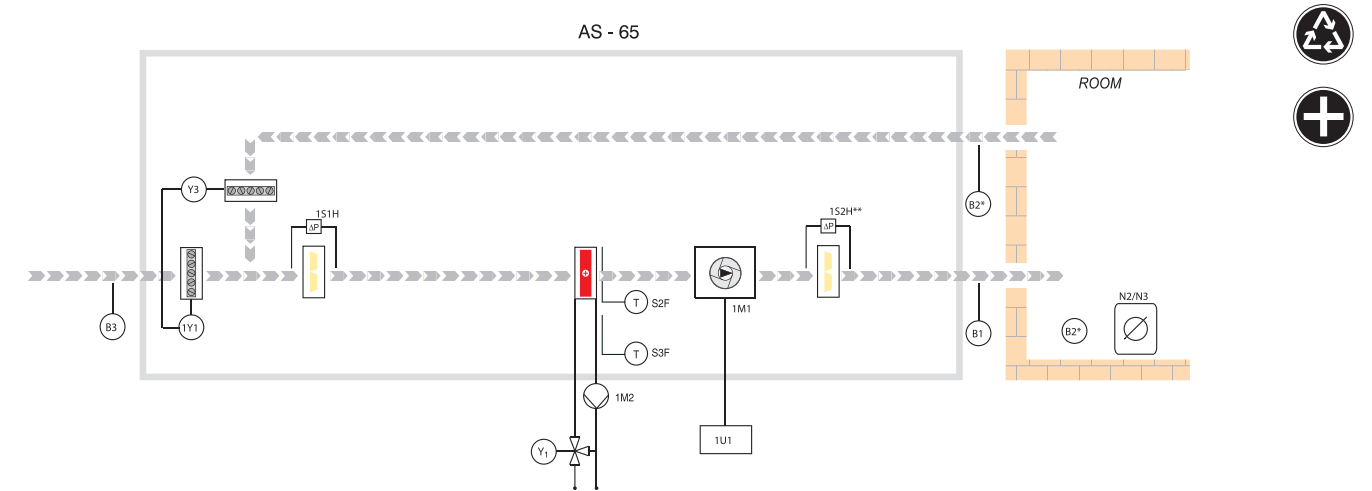
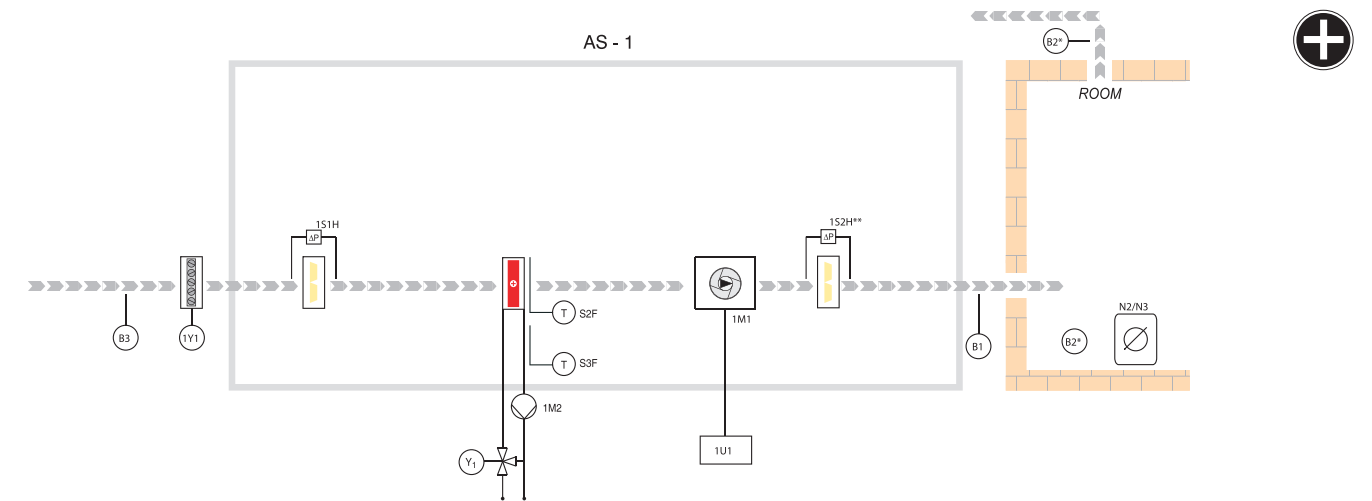

Control

Control of room temperature, optionally supply or exhaust air temperature
 Control of the energy recovery level – first stage of heating/cooling.
 Air flow control.
 Operation according to calendar – temperature, efficiency, operation mode (OPERATION, STAND-BY, STOP).
 STAND-BY – maintaining the minimum, set indoor temperature.
 * Initial heating of external air.

Information

Information on outdoor, supply, exhaust and indoor air temperatures.
 Filter contamination info.
 Alarm status info.
 Analog and digital input and output status info.

Protection

Limiting the allowed supply air temperature.
 Fan unit protection – the function is active:
 - if an electric heater is applied.
 Overload protection of a drive unit.
 Anti-frost protection of a water heater.
 Protection against overheating of an electric heater.
 Optional protection against minimal and maximal temperature of medium returning from the water heater with use of Strap-on temperature sensor, standard NTC 10K.
 The control application layouts have been prepared on the basis of water exchangers.
 The quantity of applied pressure switches for filters depends on the filters' configuration.

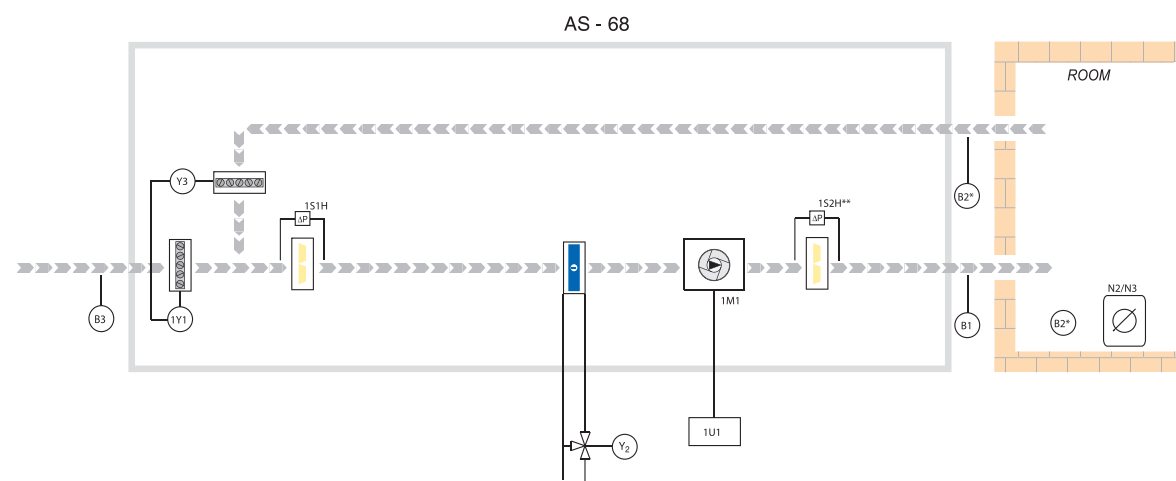
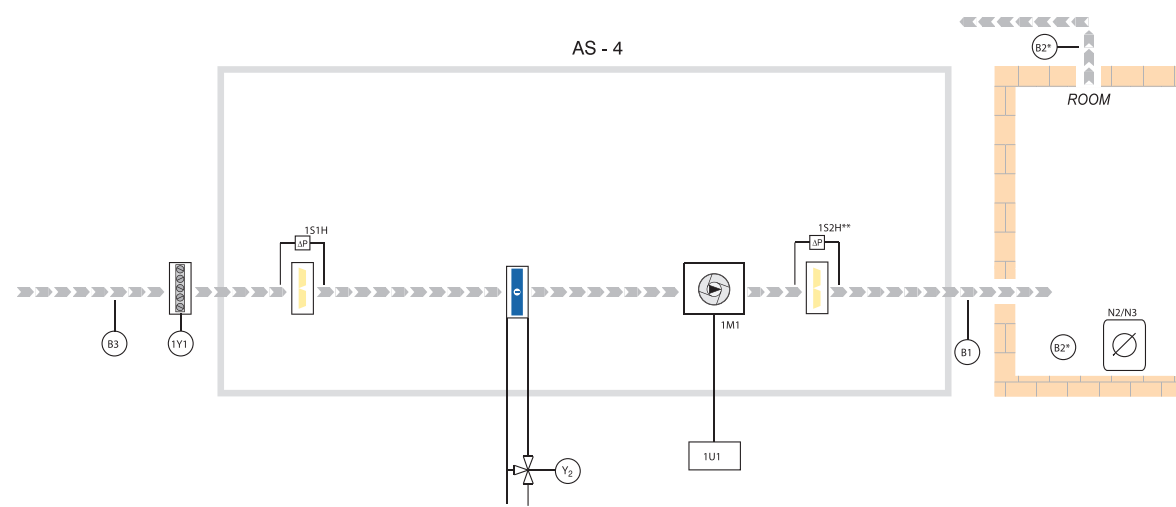

Control

Control of room temperature, optionally supply or exhaust air temperature
 Control of the energy recovery level – first stage of heating/cooling.
 Air flow control.
 Operation according to calendar – temperature, efficiency, operation mode (OPERATION, STAND-BY, STOP).
 STAND-BY – maintaining the minimum, set indoor temperature.
 * Initial heating of external air.

Information

Information on outdoor, supply, exhaust and indoor air temperatures.
 Filter contamination info.
 Alarm status info.
 Analog and digital input and output status info.

Protection

Limiting the allowed supply air temperature.
 Fan unit protection – the function is active:
 - if an electric heater is applied.
 Overload protection of a drive unit.
 Anti-frost protection of a water heater.
 The control application layouts have been prepared on the basis of water exchangers.
 The quantity of applied pressure switches for filters depends on the filters' configuration.

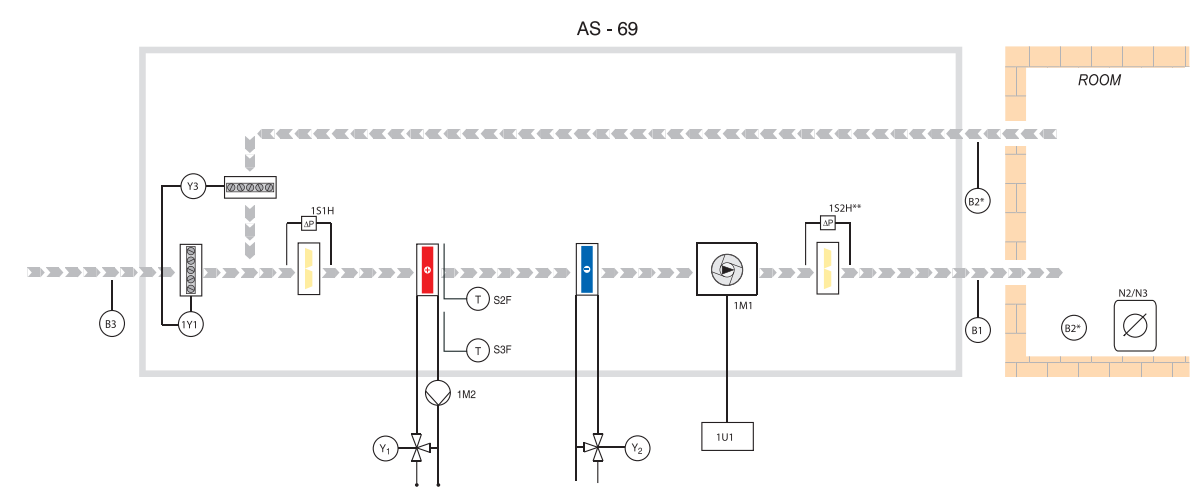
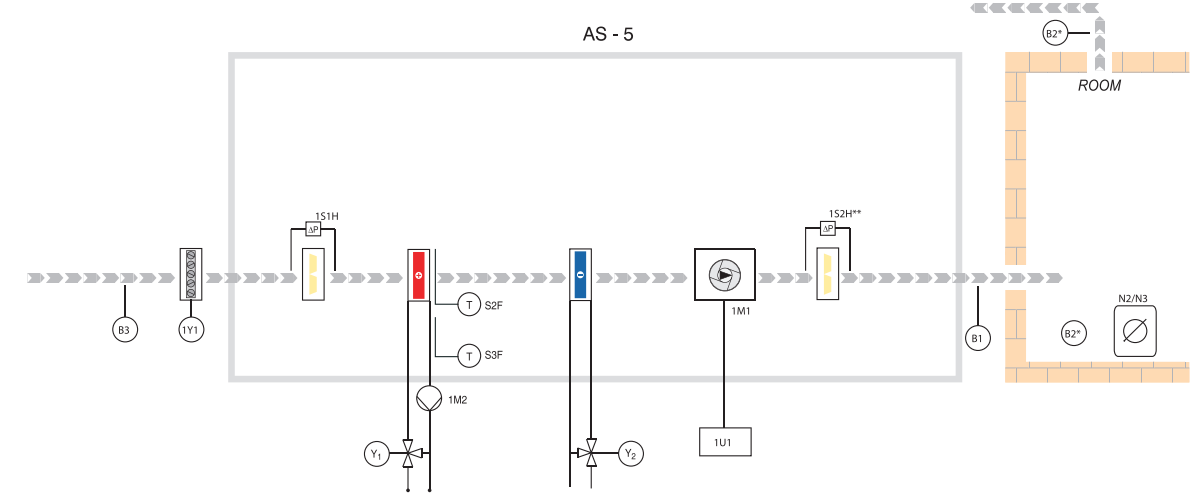

Control

Control of room temperature, optionally supply or exhaust air temperature
 Control of the energy recovery level – first stage of heating/cooling.
 Air flow control.
 Operation according to calendar – temperature, efficiency, operation mode (OPERATION, STAND-BY, STOP).
 STAND-BY – maintaining the minimum, set indoor temperature.
 * Initial heating of external air.

Information

Information on outdoor, supply, exhaust and indoor air temperatures.
 Filter contamination info.
 Alarm status info.
 Analog and digital input and output status info.

Protection

Limiting the allowed supply air temperature.
 Fan unit protection – the function is active:
 - if an electric heater is applied.
 Overload protection of a drive unit.
 Anti-frost protection of a water heater.
 Protection against overheating of an electric heater.
 The control application layouts have been prepared on the basis of water exchangers.
 The quantity of applied pressure switches for filters depends on the filters' configuration.

Control applications Supply-exhaust AHUs: cross-flow exchanger

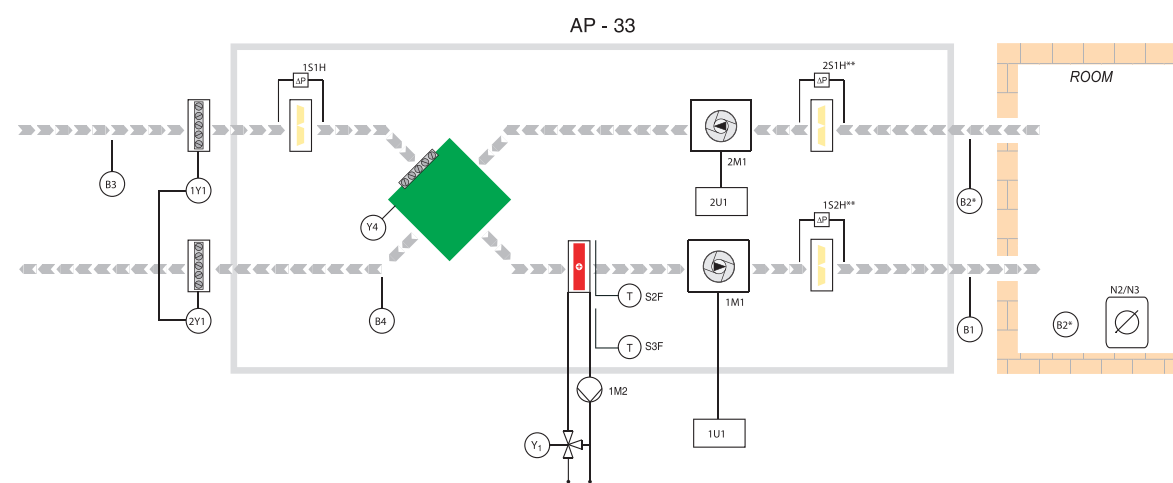
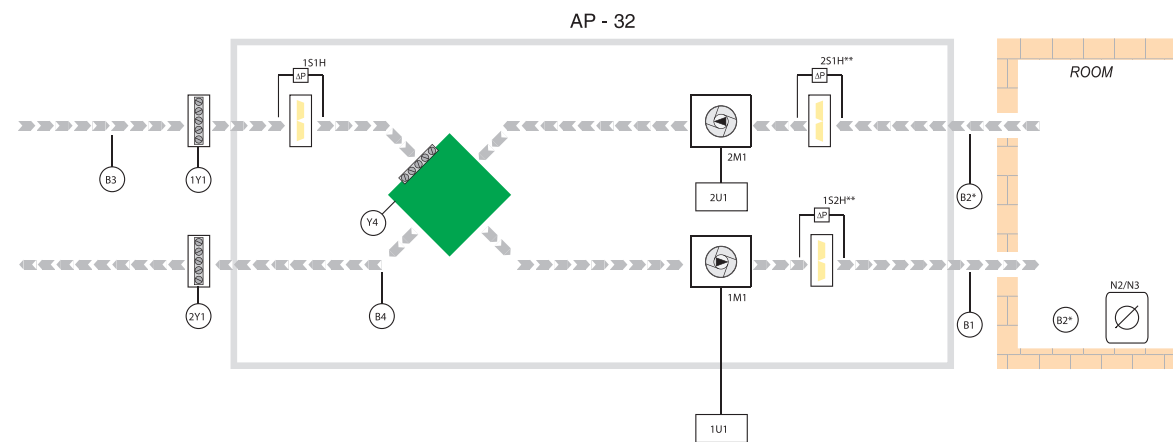

Control

Control of room temperature, optionally supply or exhaust air temperature
Control of the energy recovery level – first stage of heating/cooling.
Air flow control.
Operation according to calendar – temperature, efficiency, operation mode (OPERATION, STAND-BY, STOP).
STAND-BY – maintaining the minimum, set indoor temperature.
* Initial heating of external air.

Information

Information on outdoor, supply, exhaust and indoor air temperatures.
Filter contamination info.
Alarm status info.
Analog and digital input and output status info.

Protection

Limiting the allowed supply air temperature.
Fan unit protection – the function is active:
- if an electric heater is applied.
Overload protection of drive unit.
Anti-frost protection of a water heater.
Protection against overheating of an electric heater.
Anti-frost protection of an energy recovery exchanger.
Optional protection against minimal and maximal temperature of medium returning from the water heater with use of Strap-on temperature sensor, standard NTC 10K.
The control application layouts have been prepared on the basis of water exchangers.
The quantity of applied pressure switches for filters depends on the filters' configuration.
Optional Strap-on temperature sensor is not a part of VTS offer.

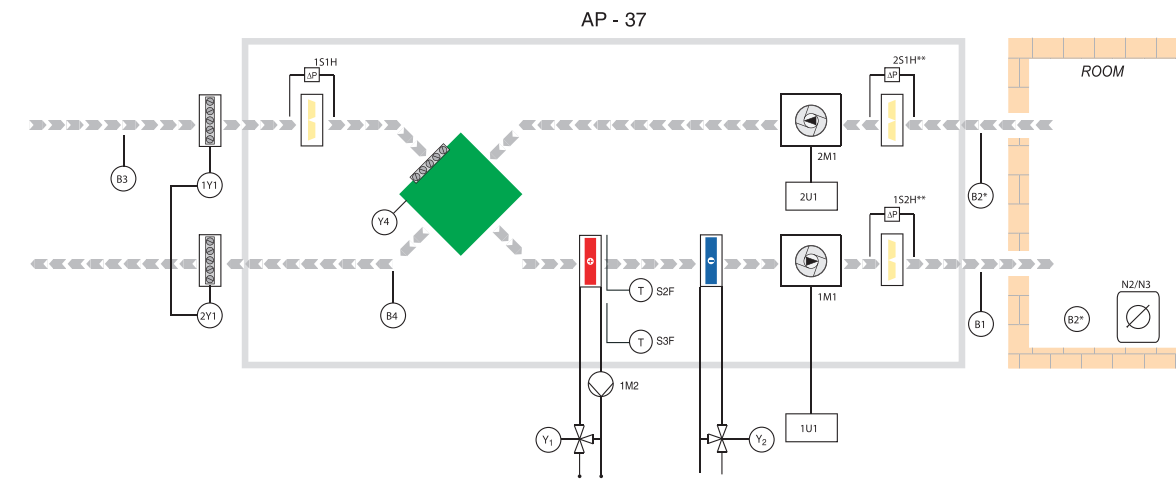
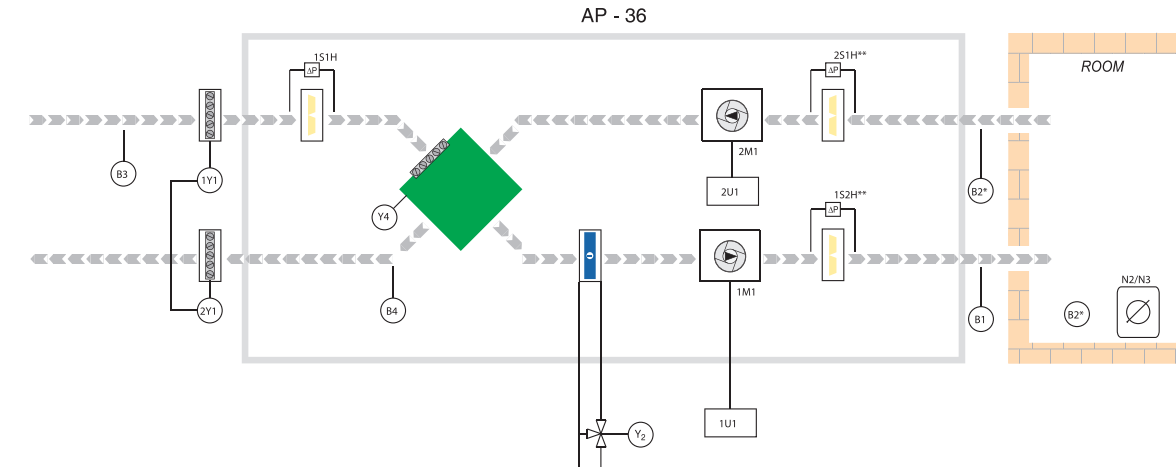

Control

Control of room temperature, optionally supply or exhaust air temperature
Control of the energy recovery level – first stage of heating/cooling.
Air flow control.
Operation according to calendar – temperature, efficiency, operation mode (OPERATION, STAND-BY, STOP).
STAND-BY – maintaining the minimum, set indoor temperature.
* Initial heating of external air.

Information

Information on outdoor, supply, exhaust and indoor air temperatures.
Filter contamination info.
Alarm status info.
Analog and digital input and output status info.

Protection

Limiting the allowed supply air temperature.
Fan unit protection – the function is active:
- if an electric heater is applied.
Overload protection of a drive unit.
Anti-frost protection of a water heater.
Protection against overheating of an electric heater.
The control application layouts have been prepared on the basis of water exchangers.
The quantity of applied pressure switches for filters depends on the filters' configuration.

Control applications Supply-exhaust AHUs: rotary exchanger

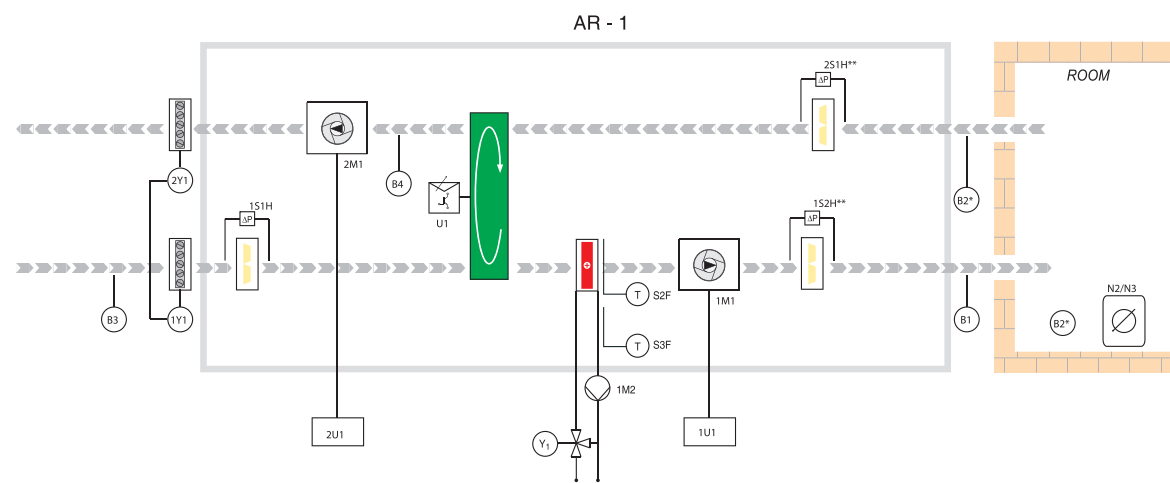
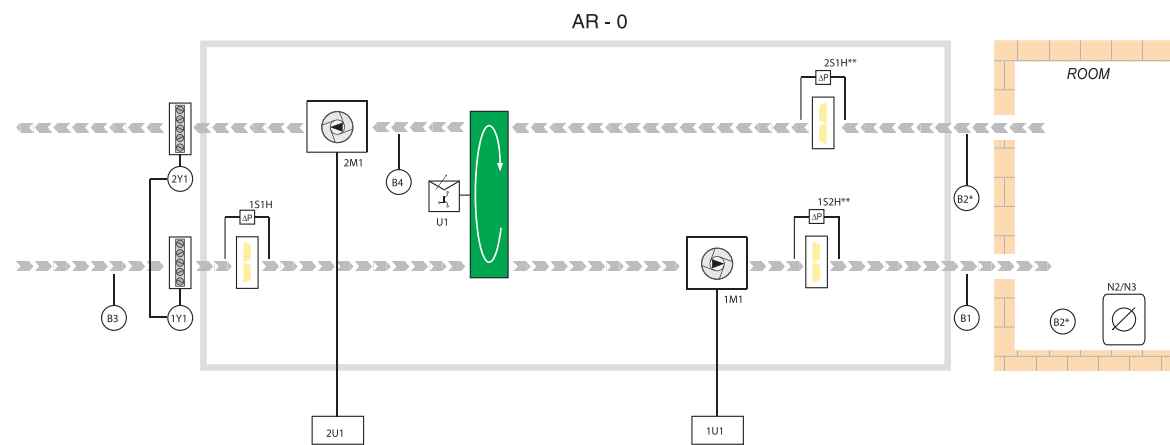

Control

Control of room temperature, optionally supply or exhaust air temperature
Control of the energy recovery level – first stage of heating/cooling.
Air flow control.
Operation according to calendar – temperature, efficiency, operation mode (OPERATION, STAND-BY, STOP).
STAND-BY – maintaining the minimum, set indoor temperature.
* Initial heating of external air.

Information

Information on outdoor, supply, exhaust and indoor air temperatures.
Filter contamination info.
Alarm status info.
Analog and digital input and output status info.

Protection

Limiting the allowed supply air temperature.
Fan unit protection – the function is active:
- if an electric heater is applied.
Overload protection of drive unit.
Anti-frost protection of a water heater.
Protection against overheating of an electric heater.
Anti-frost protection of an energy recovery exchanger.
Optional protection against minimal and maximal temperature of medium returning from the water heater with use of Strap-on temperature sensor, standard NTC 10K.
The control application layouts have been prepared on the basis of water exchangers.
The quantity of applied pressure switches for filters depends on the filters' configuration.
Optional Strap-on temperature sensor is not a part of VTS offer.

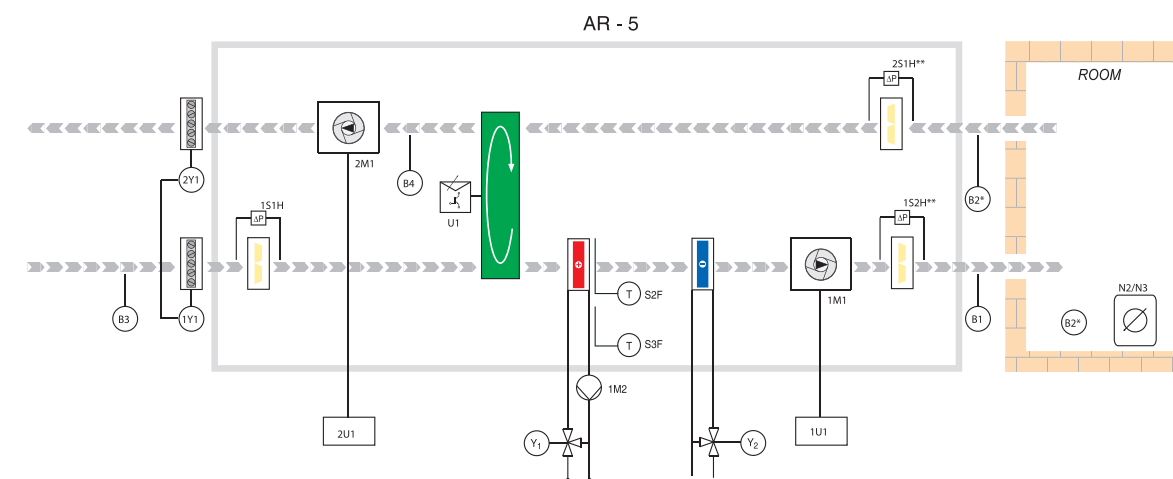
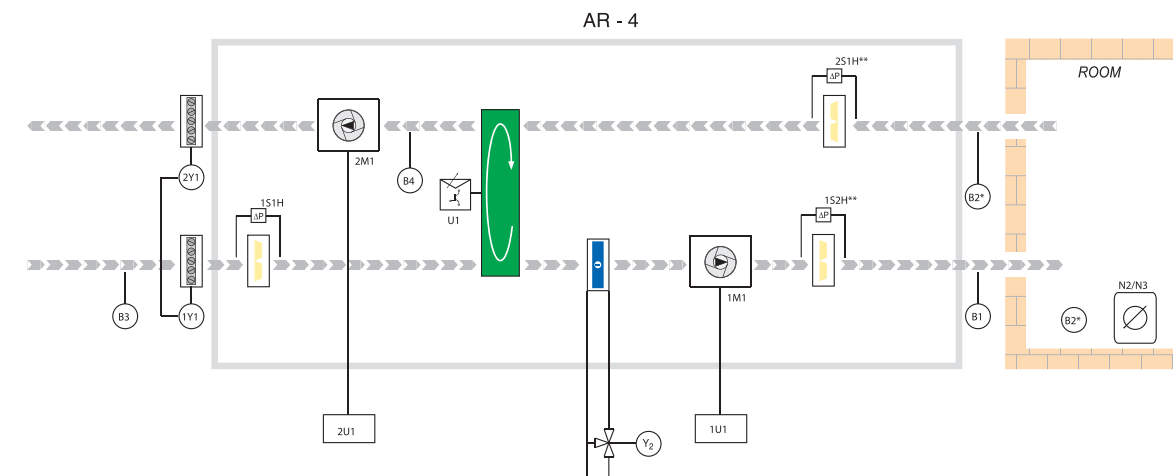

Control

Control of room temperature, optionally supply or exhaust air temperature
Control of the energy recovery level – first stage of heating/cooling.
Air flow control.
Operation according to calendar – temperature, efficiency, operation mode (OPERATION, STAND-BY, STOP).
STAND-BY – maintaining the minimum, set indoor temperature.
* Initial heating of external air.

Information

Information on outdoor, supply, exhaust and indoor air temperatures.
Filter contamination info.
Alarm status info.
Analog and digital input and output status info.

Protection

Limiting the allowed supply air temperature.
Fan unit protection – the function is active:
- if an electric heater is applied.
Overload protection of a drive unit.
Anti-frost protection of a water heater.
Protection against overheating of an electric heater.
Anti-frost protection of an energy recovery exchanger.
Optional protection against minimal and maximal temperature of medium returning from the water heater with use of Strap-on temperature sensor, standard NTC 10.
The control application layouts have been prepared on the basis of water exchangers.
The quantity of applied pressure switches for filters depends on the filters' configuration.
Optional Strap-on temperature sensor is not a part of VTS offer.

Legend:
■ Shaft Power [BHP]
■ Revolutions [RPM]
■ Acoustic Power Level [dB(A)]
■ Static Efficiency [%]

Fan performance VTS 8

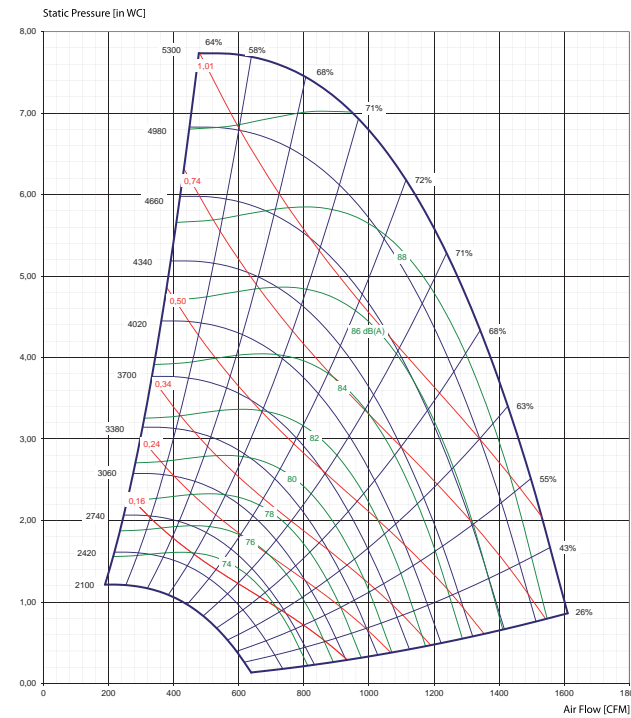

Fan performance VTS 12

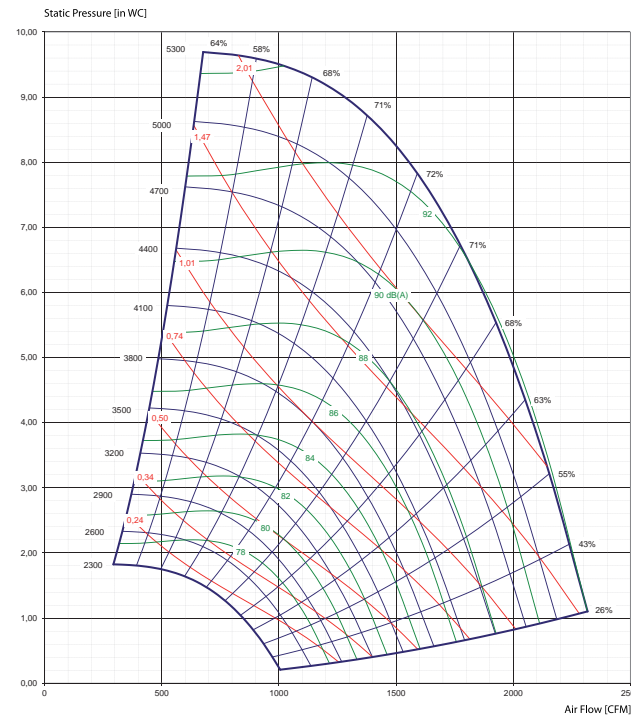

Fan performance VTS 30

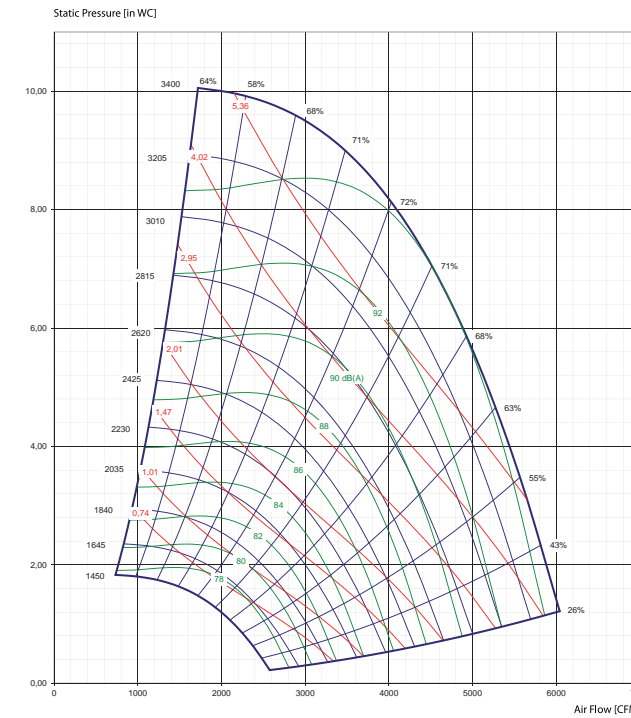

Fan performance VTS 40

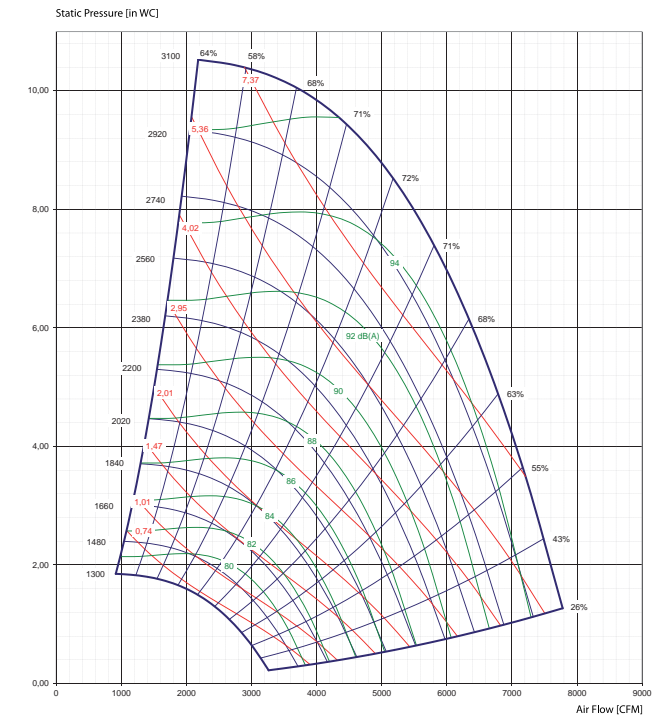

Fan performance VTS 16

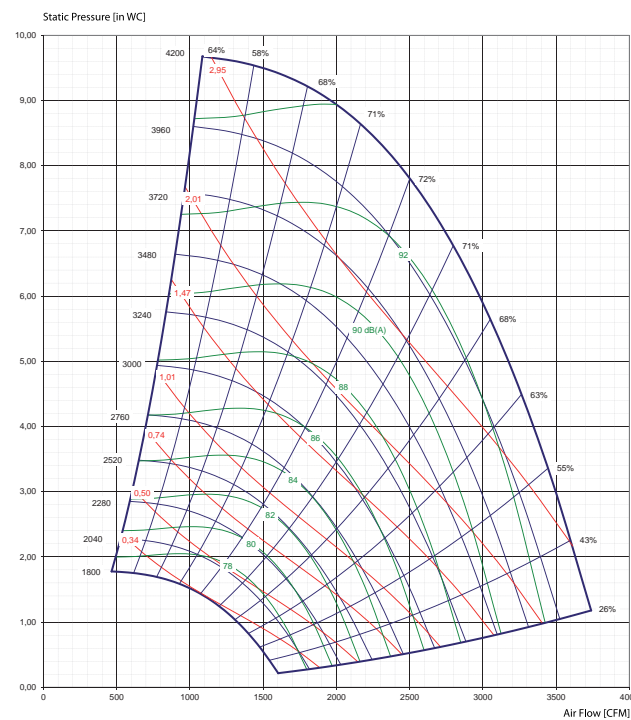

Fan performance VTS 20

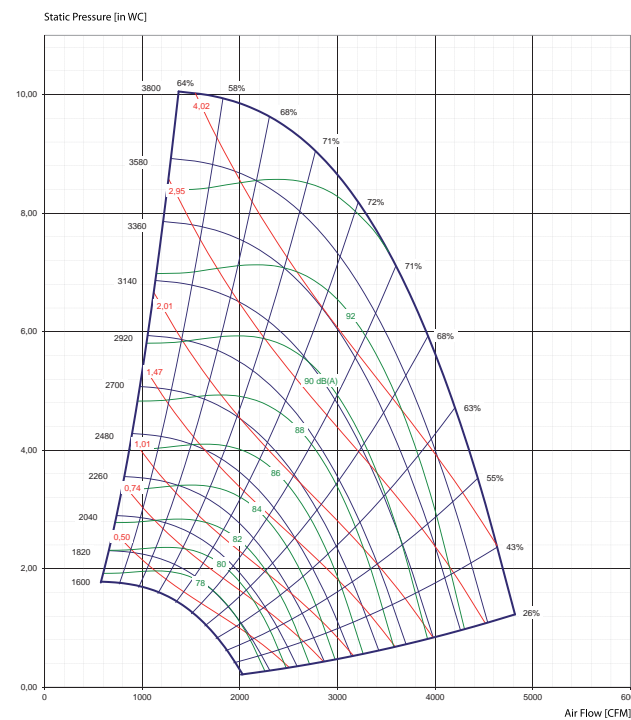

Fan performance VTS 55

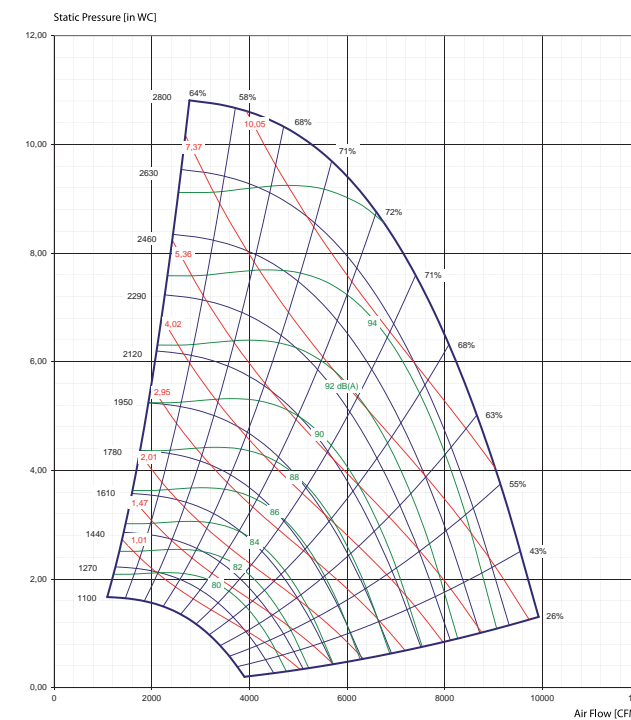

Fan performance VTS 65 and 85

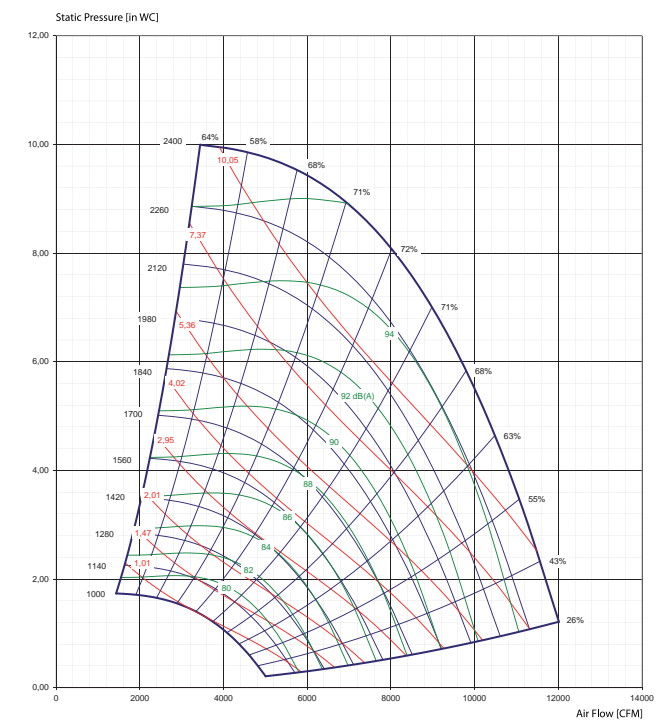

Your Global Partner in Air Handling Solution



VTS America Inc.
1650 Horizon Parkway NE, Suite 100
Buford, GA 30518
United States of America

phone: + 1-470-809-6811
fax: + 1-470-809-6815
e-mail: america@vtsgroup.com
www.vtsgroup.com