



# THE GLOBAL PLAYER

Newsletter 2/2017



## VTS **BIM** - a new approach to digital models of VENTUS air handling units

| EC motors in VOLVANO and WING

| ClimaCAD OnLine 4.0 - a new VTS products selection tool

| The most important events in the 1st half of the year- a summary

## ▶ Introduction



Dear sirs,

After a short break once again I would like to invite you to read our Newsletter.

From the beginning of business activity of VTS we have always placed emphasis on using modern and innovative technologies, since we understood that only the broadly understood technological progress applicable to all areas of company activity could enable us to gain and later maintain the position of an unquestionable leader on the market of HVAC producers. We want to continually develop and be a company which provides not only the best product, but also IT technologies that ensure the comfort and speed of work, thus making every day life much easier.

Therefore with great pleasure and satisfaction I would like to inform that a new selection software, ClinaCAD OnLine 4.0 (CCOL 4.0). will soon appear on the market.

The software utilizes state-of-the-art technologies and development platforms. The solution will be made available in a SaaS model (Software as a Service). The biggest advantage of such a solution is the fact that the system will be available from anywhere in the world, all you need is a device with a web browser and Internet access.

Special attention shall be also paid to on-line .rfa (Revit®) files generator, which is a part of CCOL 4.0. It is a unique solution on the HVAC market, which we especially direct at the designers working in Building Information Modeling (BIM) environment.

Yet another and very important issue with which we deal in this edition are the savings resulting from the use of EC motors installed in our WING air curtains and VOLCANO water heaters.

I do hope that you will find the second issue of our Magazine a good and welcome source of information!

Hanna Siek-Zagórska, President of the VTS Group

## | TABLE OF CONTENTS

▶ <b>NEW RELEASES</b>	4
VTS BIM - a new approach to digital models of VENTUS air handling units	4
ClimaCAD OnLine 4.0 - a new VTS products selection tool	8
▶ <b>AWARDS</b>	10
VTS the winner of the main award at iF Design 2017	10
▶ <b>IMPLEMENTATION</b>	12
Heaters and curtains - VTS with EC motors	12
▶ <b>EVENTS</b>	16
The most important events in the 1st half of the year - a summary	16
▶ <b>REFERENCES</b>	20



# VTS BIM - a new approach to digital models of air-handling units

In the era of shortening of investment implementation time and the increasing popularity of the delivery of components in the “Just in time” system, and also with the growing consciousness of the need to save energy, a need to optimize investment costs, operating costs and accelerate investments arose, as well as a need to accelerate the implementation of the whole process of investment design and implementation. IT tools and programmes are indispensable here.

Building Information Modeling (BIM) can be defined as a smart combination of multiple pieces of information in one place, in one digital model. BIM is nothing but just a digital reflection of the physical and functional properties of the whole object and its specific installations or used components. There are many programmes available on the market, offering BIM class. The following ones can be listed here: Autodesk

Revit®, Graphisoft ArchiCAD, BIMVision, Nemetschek Allplan, Nemetschek Vectorworks, Tekla Structures, and SketchUp.

In the MEP branch (Mechanical, Electrical and Plumbing), the models in the RFA (Revit®) format seem to be the most popular. This file format makes it possible to develop a multi-branch, parametric digital model of the building,

so it is possible to conduct various analyzes (e.g. power supply, endurance, maintenance, etc.), leading to the optimization of the investment before construction works begin. The analyses are the more precise and reliable, the more accurate the data and parameters defined in the model are. Therefore, the entire

design industry strives to ensure that only libraries provided by equipment manufacturers are in use, because they contain a set of parameters characterizing the individual components of the facility and its installations.

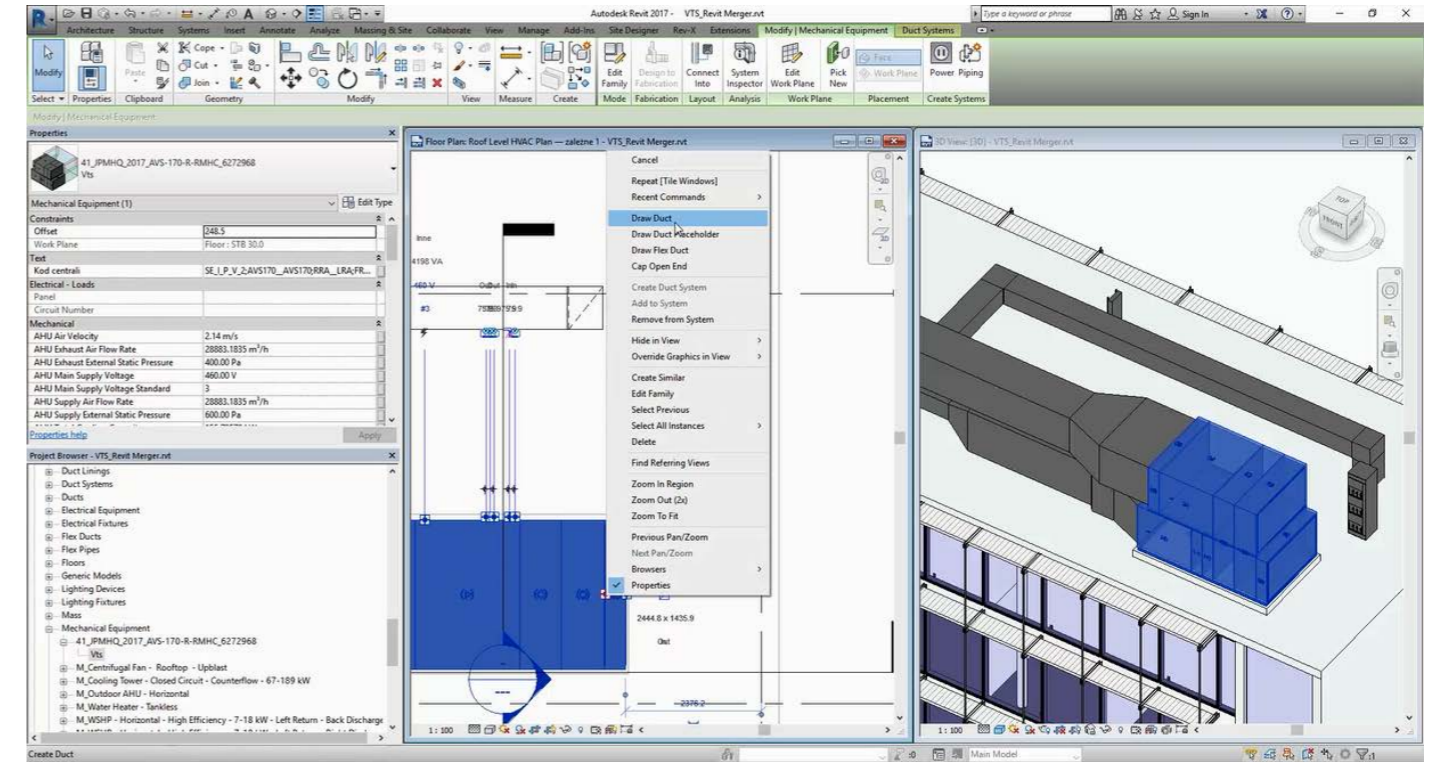

Pic. 2. Modeling air-handling ducts coming out from the VENTUS unit

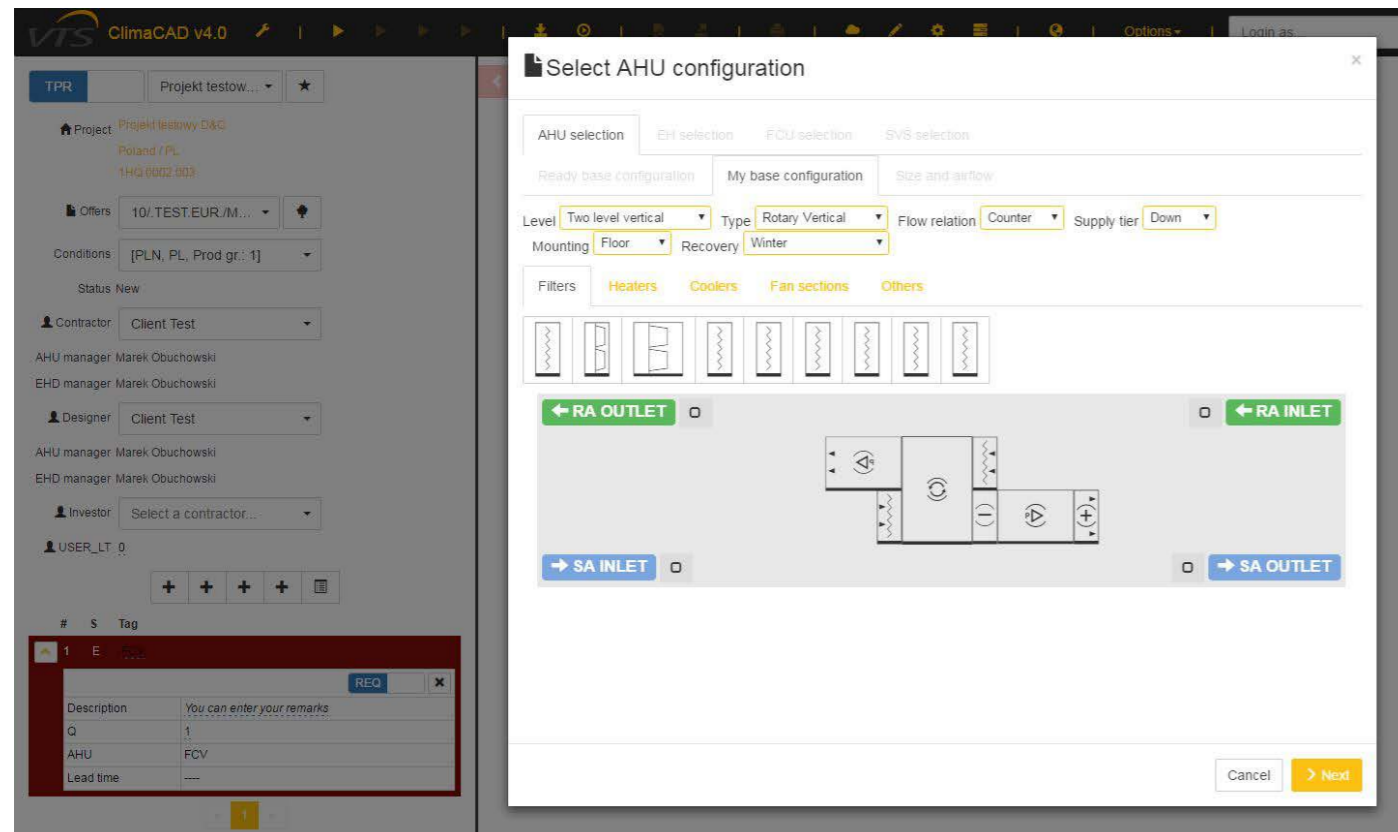

Pic. 1. The process of configuration of VENTUS air-handling units in the ClimaCAD OnLine 4.0 selection programme

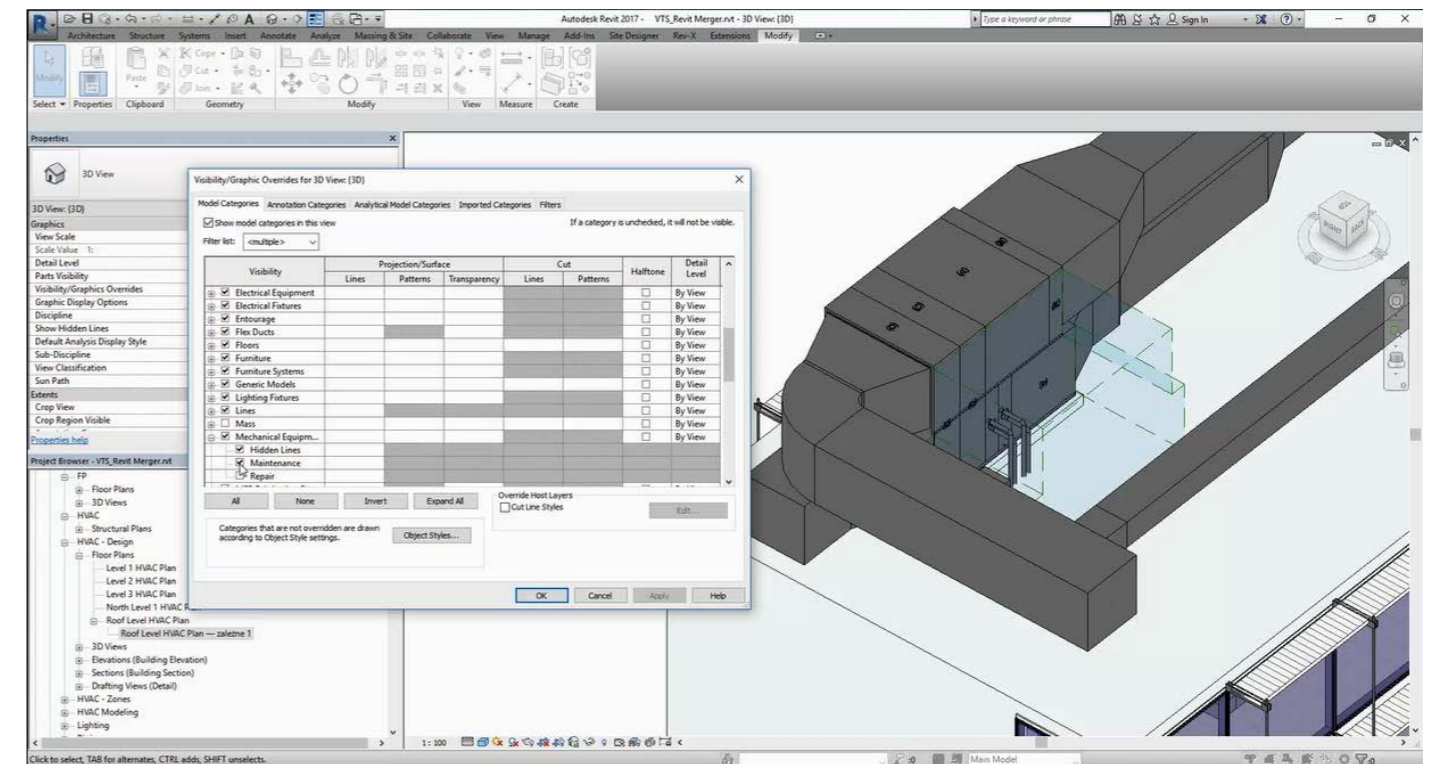

Pic. 3. An example of the service zone of the VENTUS air-handling unit

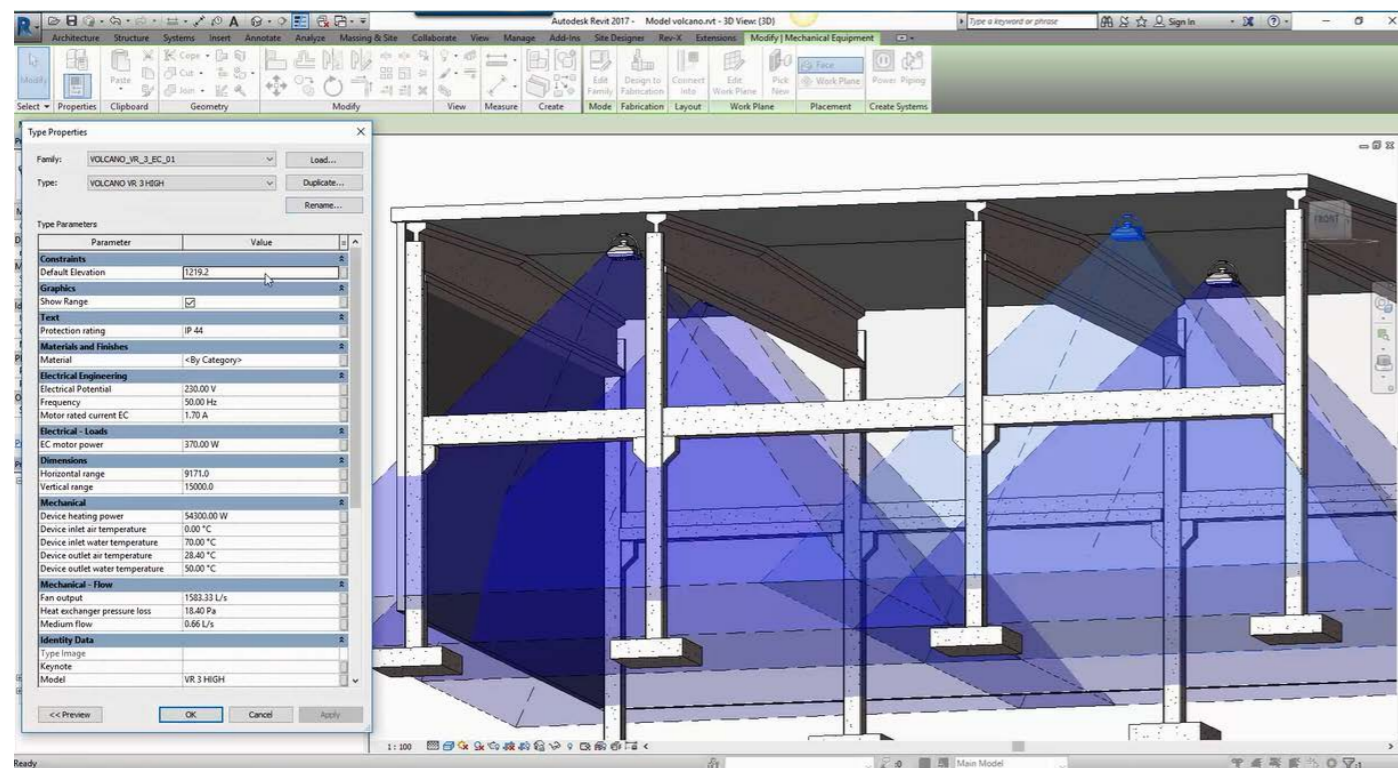

Pic. 4. VOLCANO family application in the project

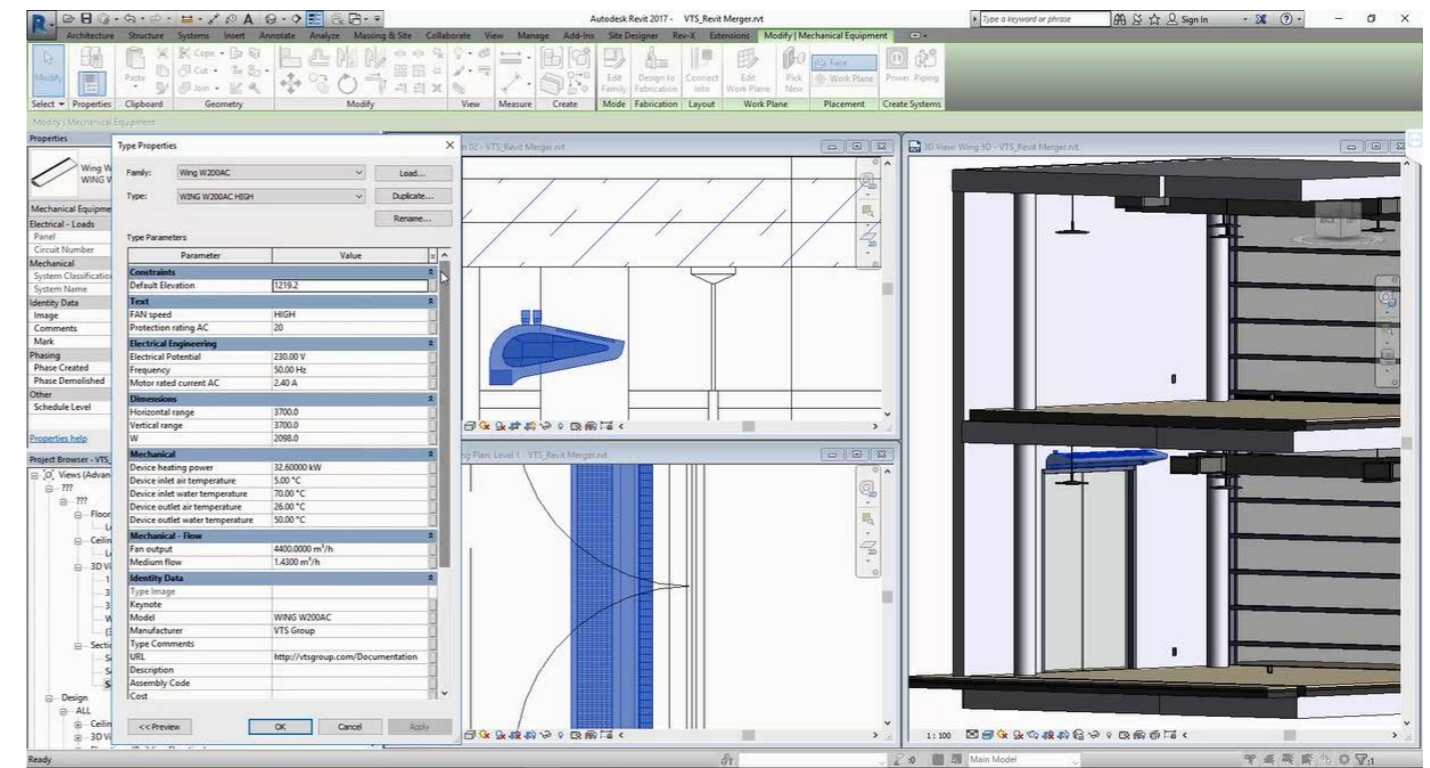

Pic. 5. WING family application in the project

### Producer libraries

More and more producers provide digital models of their products. Usually they are only example models or models containing basic nominal operating parameters with exemplary manner of their connection to installation connectors. These models are a good solution in the case of quite simple devices.

### Digital models of VTS air-handling units

The application of air-handling units cooperating with the air ducts system is related to the need to design adequate system for the whole building and the specification of the intended use of specific rooms already at the beginning of the project.

It often happens that the initial assumptions evolve during the project. The concepts of distribution of hydraulic, electrical and air systems change, together with the manner of installation connection to the air handling unit.

In such cases static producer libraries of devices contain parameters which are outdated (not following the changes), which on the other hand does not ensure updated data in the multi-branch data exchange. The libraries can be modified manually, but this process is extremely time consuming and fraught with risk of errors.

In order to meet these needs, VTS has created the possibilities of generating digital models of VENTUS air-handling models on-line. This is possible thanks to the implementation of a new ClimaCAD OnLine 4.0 selection tool, which contains RFA files generator.

The generated objects contain the parametrized connectors:

- > air ones,
- > hydraulic ones,
- > sanitary ones,
- > electric ones,

as well as the complete dimensional data, the device maintenance zone and the service (repair) zone.

Connector parameters are presented both in metric or imperial units, according to the user's preferences. Each connector can be used in the Preset or Calculating mode without the loss of data.

The new object can be generated in just few minutes.

### Digital models of WING air curtains and VOLCANO air heaters.

VTS also provides digital models of WING air curtains and VOLCANO air heaters. The models contain parametrized electric and hydraulic connectors. The families are constructed in a manner enabling the designer an intuitive selection of the correct installation, either vertical or horizontal, together with the presentation of the range of air stream. The parameter of any inclination angle of an air heater in relation to the horizontal plane is available in the case of VOLCANO air heaters. An adequate air stream has been defined for any position of device operation. The visualization of air stream scope enables the designer to distribute the devices in a way that ensures the meet design criteria.

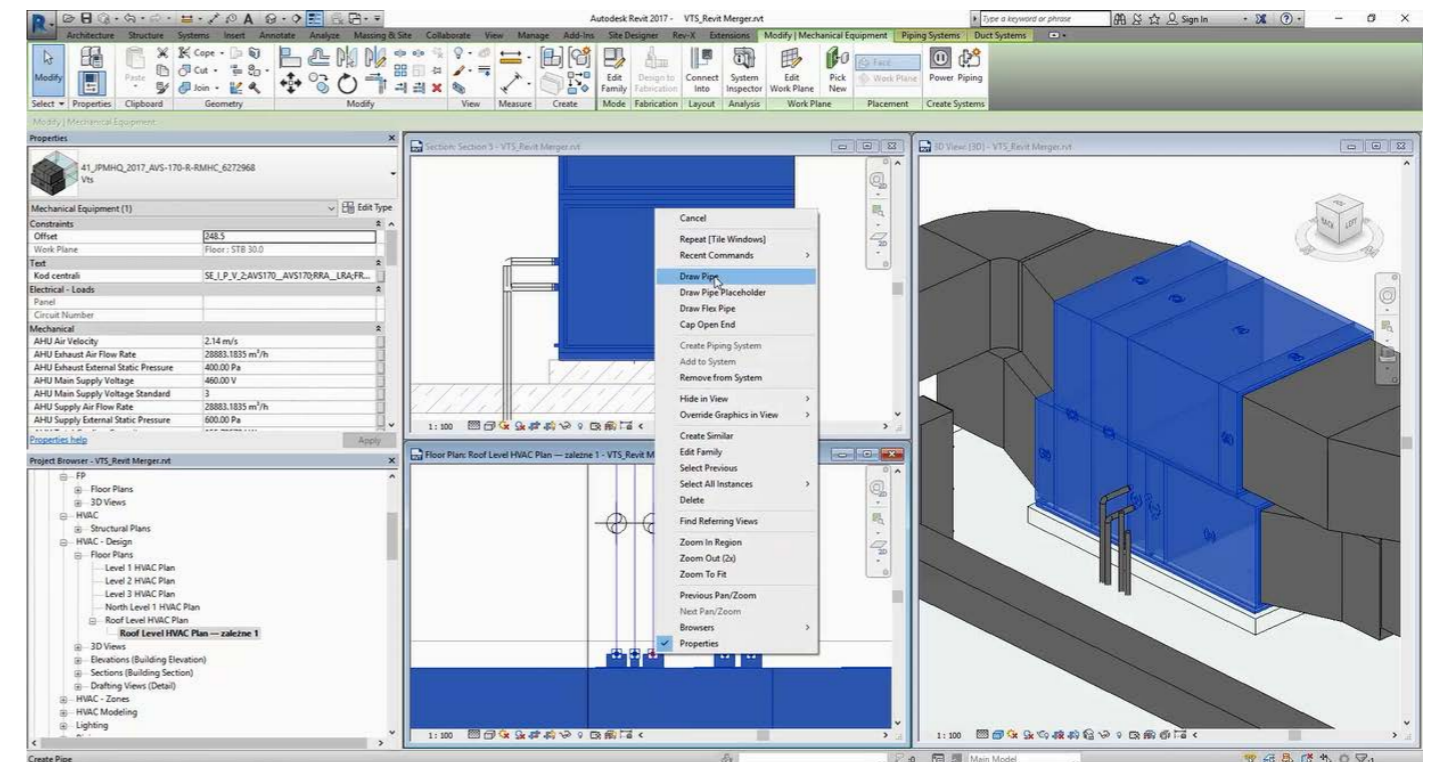

Pic. 6. An example of modelling hydraulic connectors in a VENTUS air handling unit

The release of so called families for the Autodesk Revit® environment by VTS makes it easier to design agencies to model the building installations on the basis of using the same platform. At present the on-line generator is a unique solution in BIM environment. It enables the generation of a VENTUS air-handling unit model practically in no time in any configuration and with any parameters.



# ClimaCAD OnLine 4.0 - a new VTS products selection tool

ClimaCad OnLine 4.0 (CCOL 4.0) is a new VTS products on-line selection tool. The software utilizing state-of-the-art solutions and development platforms is available in a SaaS model (Software as a Service).

The biggest advantage of such a solution is the fact that the system will be available from anywhere in the world, all you need is a device with a web browser and Internet access.

The new selection tool provides new approach to entire process of units selection. One the one hand enables to optimize the selection of the units in terms of performance and purchasing cost. On other hand new tool supports all data specification output formats like 2D or 3D CAD drawings and packaged technical submittals. Also, new ClimaCAD has been added with dynamic Revit® objects generator module, enabling to turn any Air Handling Unit selection into full of technical parameters .rfa file.

The CCOL4.0 has a dispersed structure architecture in which reliable data exchange methods based on ESP bus are applied. The dispersed structure of system architecture perfectly matches the needs of a corporation with the wide geographical scope of activity. In practice any number of software copies

can be installed on the server in any part of the world; these copies shall be synchronized with the Master unit. For the ClimaCAD user it simply means, that service will not slow down and will remain very fast, regardless of number of selections done at the same time wherever in the world.

The new selection tool offers much greater flexibility also in the scope of dimensions optimization. Very restricted static rules known from previous ClimaCad version have been replaced with dynamic device configuration algorithms. Special attention should be paid to the one supporting dynamic calculation of minimum device length, depending on actual geometry of used components and required minimum space clearance up and downstream each air treatment function. The optimum dimensions of logistic transport sections are also dynamically assigned.

The software shall be released on the turn of June and July.

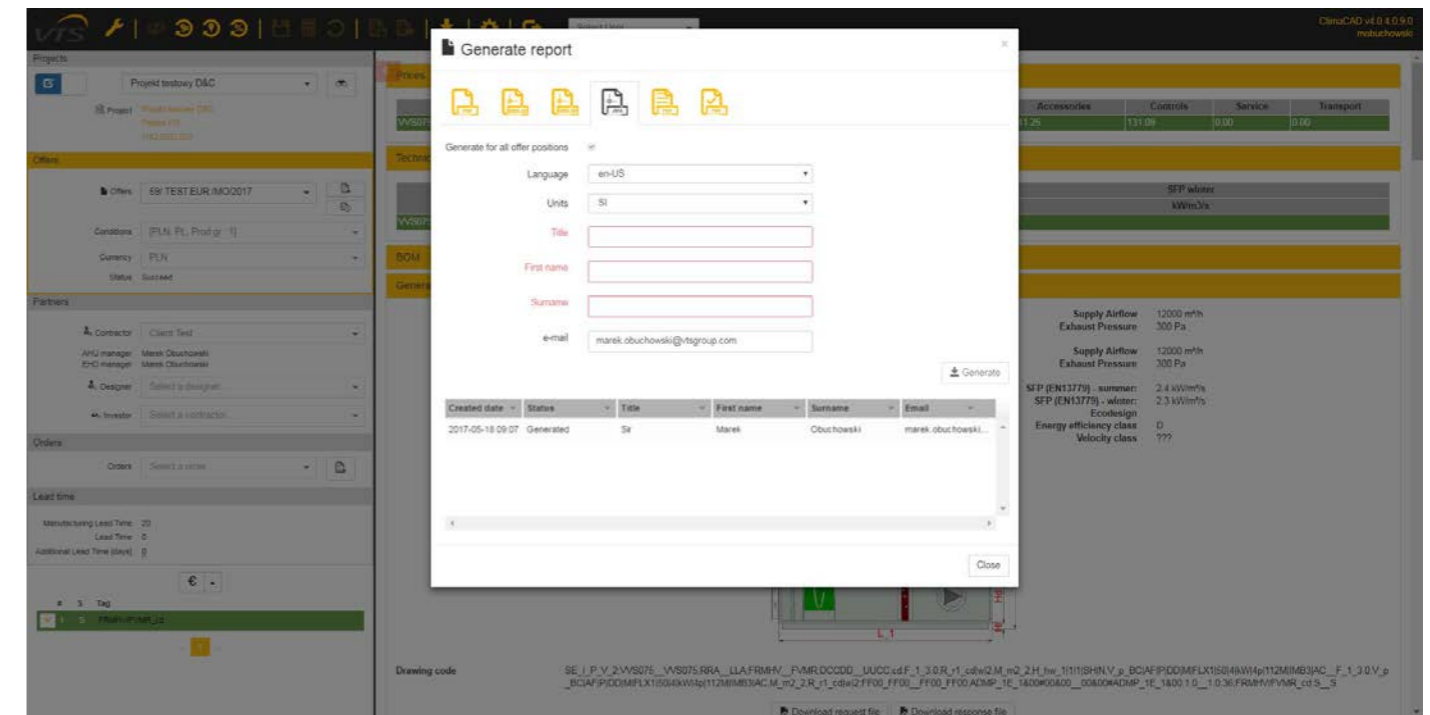

Pic. 1. Pdf, dwg and rfa descriptive and parametrical technical specification generation module.

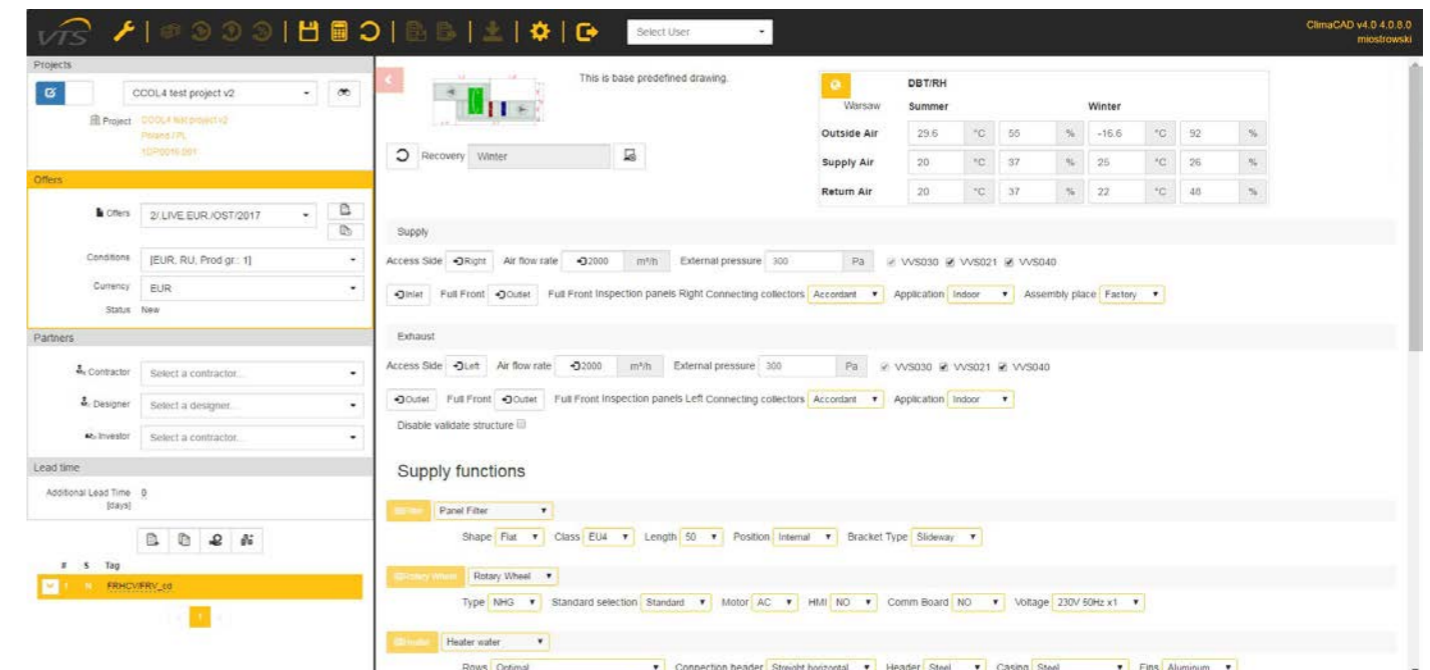

Pic. 2. Technical parameters input interface

## | VTS won an iF DESIGN AWARD 2017

VTS is a winner of this year's iF DESIGN AWARD, a world-renowned design prize. The winning product, new VOLCANO, won in the discipline air heaters, in the building technologies category. Each year, Germany's oldest independent design organization, Hannover-based iF International Forum Design GmbH, organizes the iF DESIGN AWARD.



VOLCANO won over the 58-member jury, made up of independent experts from all over the world, with its unique design. The competition was intense: over 5,500 entries were submitted from 59 countries in hopes of receiving the seal of quality.

More information about VOLCANO can be found on website [volcanobyvts.com](http://volcanobyvts.com)

Since over 60 years, the iF DESIGN AWARD has been recognized as an arbiter of quality for exceptional design. The iF label is renowned worldwide for outstanding design services, and the iF DESIGN AWARD is one of the most important design prizes in the world. Submissions are awarded in the following disciplines: Product, Packaging, Communication and Service Design, Architecture and Interior Architecture as well as Professional Concepts. All awarded entries are featured on the iF WORLD DESIGN GUIDE, in the iF design app and are displayed at the iF design exhibition Hamburg.

## Award ceremony



## | VTS Heaters and curtains - with EC motors

**Growing demand for energy arising from economic growth imposes a necessity to reduce costs of its consumption. Motors, applied in a different kind of devices, account for a considerable share in energy consumption. Therefore, their producers aim at using drives with reduced power consumption.**

**VTS company - specializing in selling heaters and curtains - has also prepared its offer of devices with energy-saving EC motors.**

EC motor is an electronically commutated brushless direct current motor. It is composed inter alia of a rotor with permanent magnets and stator with windings. Non-application of a commutator and brushes - elements used in traditional motors which wear away very quickly - made it possible to considerably extend electronically commutated motors life-time.

The main advantage of EC drives over traditional AC ones is their efficiency at wide range of regulation as well as its superb live-time at practically zero maintenance costs. EC motor as an electric machine is silent even with considerable revolutions, which has a favourable influence on acoustics of devices in which these motors are installed – VOLCANO EC and WING EC.



Fig. EC motors are crucial elements with which modernized VOLCANO heaters and Wing air curtains by VTS have been equipped



Fig. Air curtain VTS WING W150 EC

### VOLCANO heaters and Wing air curtains

EC motors are crucial elements with which modernized VOLCANO heaters and Wing air curtains by VTS have been equipped. Installation of this type of drives in devices brings specific benefits for customers: reduction of exploitation costs and maintenance costs, silent work and extended exploitation period. Another advantage is simple connection with controllers. The motor connected to mains only requires to provide the 0-10 V signal DC to be able to adjust its revolutions.

### Silent work of devices with EC motors

The fan assembly, i.e. the motor in combination with optimized, in aerodynamic terms, shape of the impeller blades decide about effective air blow. Its precise fitting with casing of VOLCANO heaters and even air flow inside the device are the guarantee of maximum efficiency with the lowest level of acoustic power radiated to the environment.

With regard to air curtains, device work acoustics is also a key element because devices of this type work e.g. in representative entry zones of buildings (theatres, restaurants etc.). WING curtain equipped with EC motors reduces the level of emitted

sound and it is additionally reduced by precise adaptation of capacity and range to structure's needs thanks to the use of WING EC controller.

### Comparison of device operational costs

The following table presents comparison of costs of an investment consisting in buying 8 heaters VR2 in version EC or AC, heating a building with cubic capacity of 6600 m<sup>3</sup>. The calculations do not include water heating costs and costs of its supply assuming that in both variants analysed they would be equal.

Assumptions regarding the building and ambient conditions:

- > Room dimensions: 55 x 30 x 4 m
- > Thermal insulation of the building: poor
- > Design outdoor temperature: -20°C
- > Expected indoor temperature: 15°C
- > Demand for heating capacity: 150 kW
- > Heating medium temperature: 60/40°C
- > Electric energy price: 0.61 PLN/kWh

Heaters work parameters:

- > Fan speed setting: 2
- > Number of heaters working hours within a year: 1,792 h
- > Number of years of heaters work taken for the calculations: 5

Comparison of purchase and exploitation costs of VOLCANO heaters in version AC and EC		
Device	VR 2 AC	VR 2 EC
	Gear 2	Gear 2
Exhaust flow rate:	3600 m <sup>3</sup> /h	3600 m <sup>3</sup> /h
Motor electric power	0,243 kW	0,089 kW
Cost of buying 8 VOLCANO VR 2 devices together with controls and fittings (net)	14 048 zł	16 921 zł
Annual energy consumption cost (8 x VR2)	2 125 zł	778 zł
Cost of electric energy consumed within 5 years (8 x VR2)	10 625 zł	3 890 zł
Total cost after 5 years of using	24 673 zł	20 811 zł
<b>Savings within 5 years</b>	<b>3862 PLN (16%)</b>	

The compilation shows that the cost of buying the heaters with EC motors will pay off after approx. 2 years, and 5-year exploitation will allow achieving savings of nearly PLN 3900.

Due to the fact that performance of EC and AC motors has the largest difference at work in the lowest fan revolutions settings (see figure below), comparison of costs in such a case would show a possibility of achieving even greater benefits. Taking account of the fact that the heaters, as a rule, work in lower gears, savings arising from application of EC motors are obvious.

Comparison of motor performance values

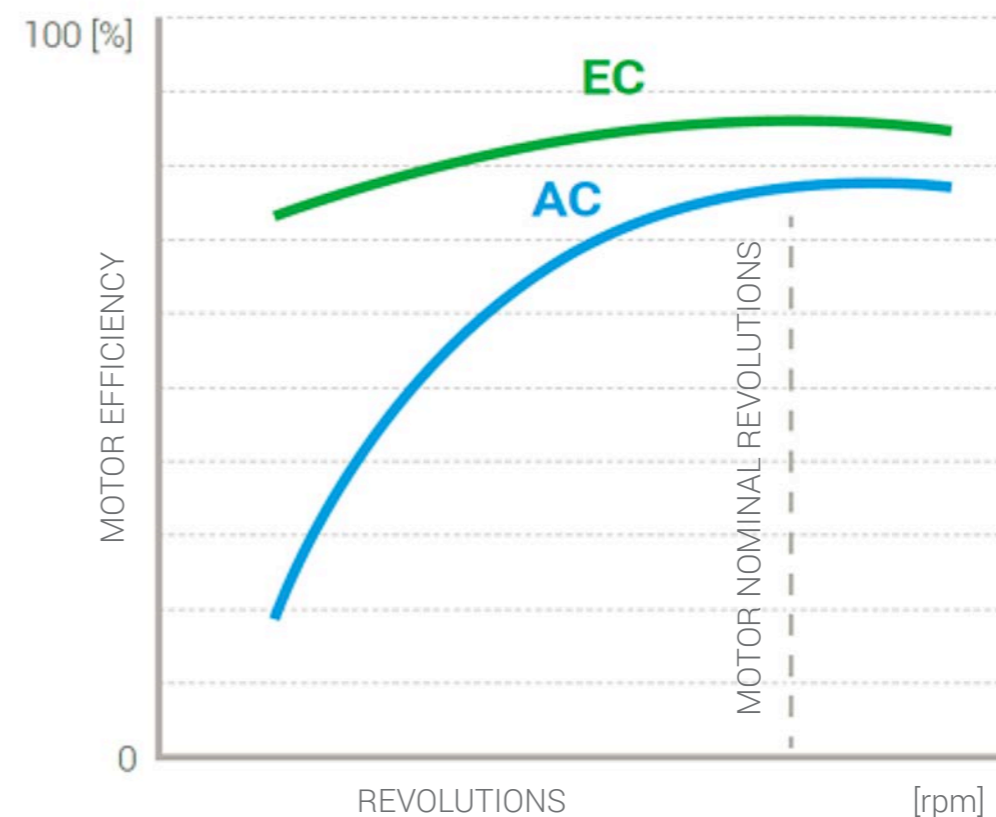

**Legislation changes and further trends in technology**

The European Union and Poland as the Member State undertake to reduce emission of CO2 by at least 20% by 2020. To achieve the pre-set objective, it is necessary to introduce increasingly restrictive standards and with reference to HVAC sector to use more and more efficient electric devices i.e. motors or fans.

According to one of the EU regulations on this matter (Regulation WE640/2009), the European Union imposes,

at intervals, minimum efficiency thresholds and classes of motors used, at the same time decreasing the quantity of wasted energy. Last change in this issue was introduced in 2017. There are also many other standards and regulations aimed at forcing producers to diminish the quantity of wasted energy gradually and manage already generated energy better. In line with these trends, it becomes natural to apply energy-saving solutions (such as EC motors) and manage energy more efficiently. This, in turn, necessitates investments in renewable sources of energy and devices using such sources as e.g. VOLCANO VR3 heater and heat pumps.



# The most important events in the 1st half of the year- a summary

[READ MORE >](#)

## Las Vegas Country Club event

Month - **January**  
Time of duration - **2 days**  
Location - **Las Vegas**  
Number of participants - **290**

## ISH fair

Month - **March**  
Time of duration - **3 days**  
Location - **Frankfurt am Mein**  
The number of persons who visited our stand - **approx. 1500**

## A seminar combined with an integration trip to Sweden

Month - **April**  
Time of duration - **3 days**  
Location - **Gdynia, Karlskrona**  
Number of participants - **150**

## CREXPO fair

Month - **April**  
Time of duration - **3 days**  
Location - **Shanghai**  
The number of persons who visited our stand - **approx. 2000**



Las Vegas  
Country Club event



The fair  
ISH



A seminar combined with  
an integration trip to Sweden

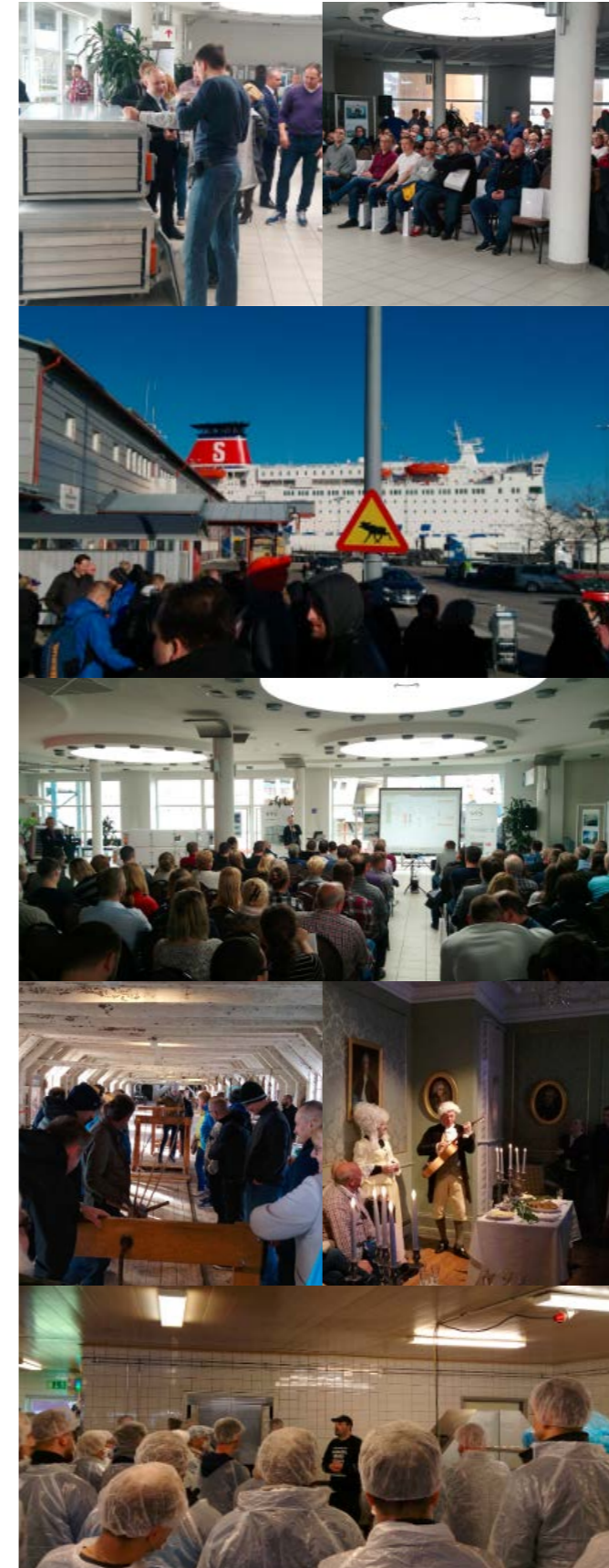

The fair  
CREXPO

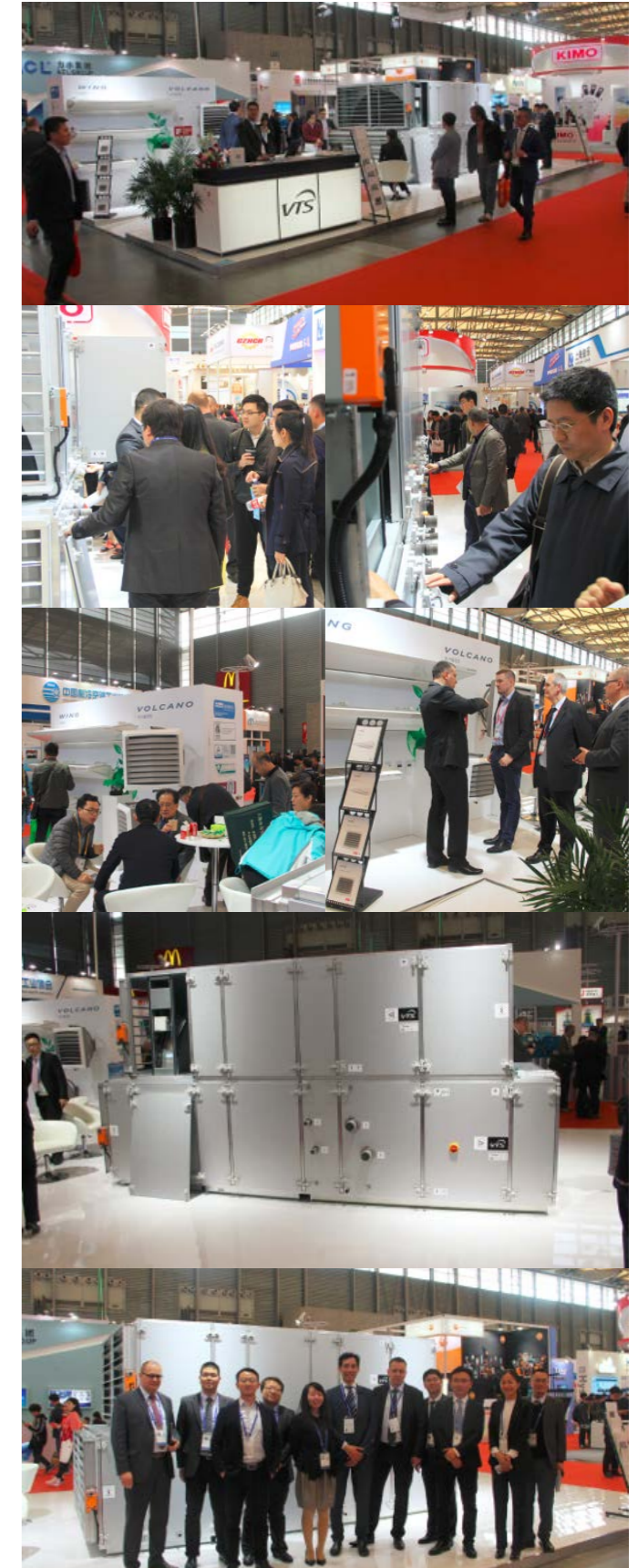

▶ REFERENCES



Name of building: **Beaumont (Seth Creators)**  
Country: **India**  
City: **Sion**  
Units: **VENTUS**



Name of building: **Commercial Development for Al Fardan Properties**  
Country: **Qatar**  
City: **Doha**  
Units: **VENTUS**



Name of building: **Oberoi Realty, Worli**  
Country: **India**  
City: **Mumbai**  
Units: **VENTUS**



Name of building: **Audi & Porsche Showroom**  
Country: **Poland**  
City: **Warsaw**  
Units: **VENTUS**



Name of building: **Hilton Hotel**  
Country: **Sierra Leone**  
City: **Freetown**  
Units: **VENTUS**



Name of building: **BC Seifullin Plaza**  
Country: **Kazakhstan**  
City: **Almaty**  
Units: **VENTUS**



Name of building: **Messila Resort and Spa**  
Country: **Qatar**  
City: **Doha**  
Units: **VENTUS**



Name of building: **Sala de Sport Multifunctionala**  
Country: **Romania**  
City: **Cluj**  
Units: **VENTUS**



Name of building: **Sky Venture**  
Country: **UAE**  
City: **Abu Dhabi**  
Units: **VENTUS**



Name of building: **Military Medical Academy**  
Country: **Russia**  
City: **Saint Petersburg**  
Units: **VENTUS**



Name of building: **Amity University**  
Country: **India**  
City: **Mumbai**  
Units: **VENTUS**



Name of building: **Manjeera Mtc**  
Country: **India**  
City: **Hyderabad**  
Units: **VENTUS**



Name of building: **Mingzhu International Commercial Building**  
Country: **China**  
City: **Hangzhou, Zhejiang**  
Units: **VENTUS**



Name of building: **BMW Painting Factory**  
Country: **Germany**  
City: **Dingolfing**  
Units: **VENTUS**



Name of building: **Holiday Inn Express**  
Country: **Kazakhstan**  
City: **Astana**  
Units: **VENTUS**



Name of building: **Siemens**  
Country: **India**  
City: **Vikhroli**  
Units: **VENTUS**



▶ REFERENCES



Name of building: **Omega Distribution Center Warehouses**  
Country: **UAE**  
City: **Dubai**  
Units: **VENTUS**



Name of building: **BC 7 One**  
Country: **Russia**  
City: **Moscow**  
Units: **VENTUS**



Name of building: **UI Cyberpark**  
Country: **India**  
City: **Kerala**  
Units: **VENTUS**



Name of building: **Atlantic Cape Community College**  
Country: **USA**  
City: **Landing, New Jersey**  
Units: **American VENTUS**



Name of building: **Aviation Technical Centre AIR-Astana**  
Country: **Kazakhstan**  
City: **Astana**  
Units: **VENTUS**

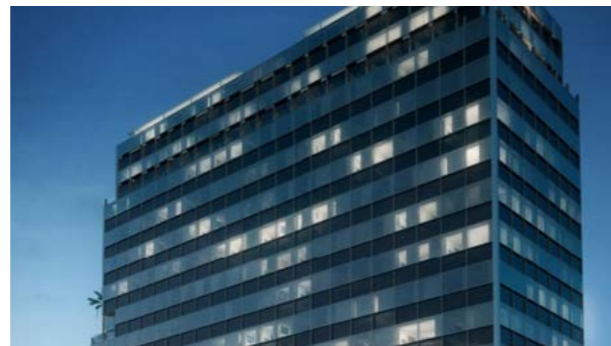

Name of building: **Novotel Hotel**  
Country: **UAE**  
City: **Sharjah**  
Units: **VENTUS**



Name of building: **Amul**  
Country: **India**  
City: **Anand**  
Units: **VENTUS**



Name of building: **Al Rahmaniya Mall**  
Country: **UAE**  
City: **Sharjah**  
Units: **VENTUS**



Name of building: **India Bulls Finance Centre**  
Country: **India**  
City: **Mumbai**  
Units: **VENTUS**



Name of building: **Raffles Residency**  
Country: **India**  
City: **Bangalore**  
Units: **VENTUS**



Name of building: **Cream Bell**  
Country: **India**  
City: **Kolkata**  
Units: **VENTUS**



Name of building: **Ashwin Medical Hospital**  
Country: **India**  
City: **Kathmandu**  
Units: **VENTUS**

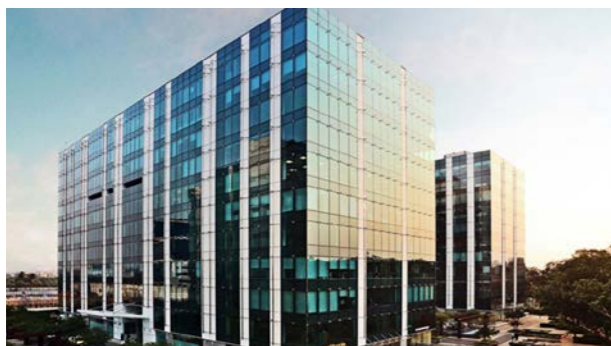

Name of building: **Maker Maxcity**  
Country: **India**  
City: **Mumbai**  
Units: **VENTUS**



Name of building: **Transport Hub Khodynka**  
Country: **Russia**  
City: **Moscow**  
Units: **VENTUS**



Name of building: **Hotel Leela**  
Country: **India**  
City: **Goa**  
Units: **VENTUS**



Name of building: **Pepsico**  
Country: **Romania**  
City: **Dragomiresti Vale**  
Units: **VENTUS**



WE INVITE YOU TO OUR ONLINE STORE

## WING

Air curtain



from EURO **511,68**

BUY  
NOW



## VOLCANO

Water heater



from EURO **403,44**

## FILTERS



from EURO **9,10**

BUY  
NOW



CHECK THE NEW,  
LOWER PRICES

for all filters

## PUMP GROUP

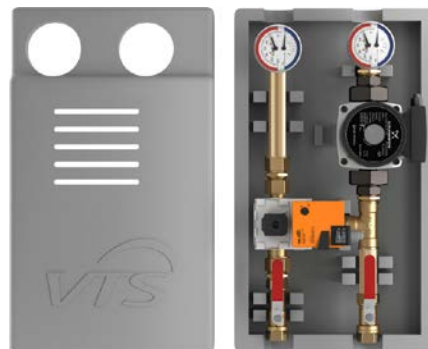

from EURO **483,48**

BUY  
NOW



[eshop.vtsgroup.com](http://eshop.vtsgroup.com)

